

# **SERVICE MANUAL**

## **(Machine code: C235)**

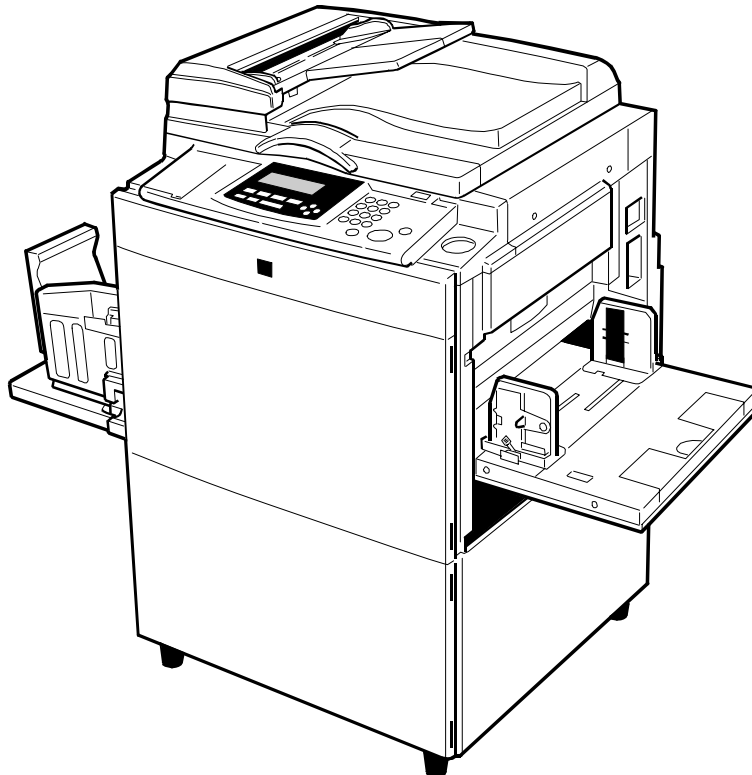

C235V515.WMF

# IMPORTANT SAFETY NOTICES

## PREVENTION OF PHYSICAL INJURY

1. Before disassembling or assembling parts of the printer and peripherals, make sure that the power cord is unplugged.
2. The wall outlet should be near the printer and easily accessible.
3. If any adjustment or operation check has to be made with exterior covers off or open while the main switch is turned on, keep hands away from electrified or mechanically driven components.

## HEALTH SAFETY CONDITIONS

1. If you get ink in your eyes by accident, try to remove it with eye drops or flush with water as first aid. If unsuccessful, get medical attention.
2. If you ingest ink by accident, induce vomiting by sticking a finger down your throat or by giving soapy or strong salty water to drink.

## OBSERVANCE OF ELECTRICAL SAFETY STANDARDS

1. The printer and its peripherals must be installed and maintained by a customer service representative who has completed the training course on those models.

### CAUTION

**The RAM has a lithium battery which can explode if handled incorrectly. Replace only with the same type of RAM. Do not recharge or burn this battery. Used RAM's must be handled in accordance with local regulations.**

### ATTENTION

**La carte RAM comporte une pile au lithium qui présente un risque d'explosion en cas de mauvaise manipulation. Remplacer la pile uniquement par une carte RAM identique. Ne pas recharger ni brûler cette pile. Les cartes RAM usagées doivent être éliminées conformément aux réglementations locales.**

## **SAFETY AND ECOLOGICAL NOTES FOR DISPOSAL**

1. Dispose of replaced parts in accordance with local regulations.
2. Used ink and masters should be disposed of in an environmentally safe manner and in accordance with local regulations.
3. When keeping used lithium batteries (from the main processing units) in order to dispose of them later, do not store more than 100 batteries (from the main processing units) per sealed box. Storing larger numbers or not sealing them apart may lead to chemical reactions and heat build-up.

# TABLE OF CONTENTS

<b>1. OVERALL INFORMATION .....</b>	<b>1-1</b>
1.1 ESSENTIAL DIFFERENCES BETWEEN C235 AND C229 MODELS .....	1-1
1.2 SPECIFICATIONS.....	1-3
1.3 GUIDE TO COMPONENTS AND THEIR FUNCTIONS .....	1-7
1.3.1 MACHINE EXTERIOR.....	1-7
1.4 MACHINE INTERIOR.....	1-8
1.4.1 OPERATION PANEL.....	1-10
1.4.2 INDICATORS .....	1-12
1.5 PRINTING PROCESS OVERVIEW.....	1-13
1.6 MECHANICAL COMPONENT LAYOUT .....	1-14
1.7 ELECTRICAL COMPONENT LAYOUT .....	1-15
1.7.1 PRINTED CIRCUIT BOARD LAYOUT .....	1-15
1.7.2 SCANNER SECTION .....	1-16
1.7.3 PAPER FEED SECTION.....	1-16
1.7.4 MASTER EJECT, PRESSURE CYLINDER, AND OTHER SECTIONS.....	1-17
1.7.5 PAPER DELIVERY SECTION.....	1-18
1.7.6 MASTER MAKING UNIT .....	1-18
1.7.7 DRUM UNIT .....	1-19
1.7.8 TABLES OF ELECTRICAL COMPONENTS .....	1-20
Boards .....	1-20
Solenoids.....	1-20
Switches .....	1-20
Motors.....	1-21
Sensors.....	1-22
Others .....	1-24
1.8 DRIVE LAYOUT .....	1-25
1.8.1 OVERVIEW .....	1-25
1.8.2 MAIN DRIVE.....	1-26
<b>2. DETAILED SECTION DESCRIPTIONS .....</b>	<b>2-1</b>
2.1 SCANNER AND OPTICS .....	2-1
2.1.1 OVERVIEW .....	2-1
2.1.2 SCANNER DRIVE .....	2-1
2.1.3 ORIGINAL SIZE DETECTION IN PLATEN MODE.....	2-2
2.2 IMAGE PROCESSING .....	2-4
2.2.1 OVERVIEW .....	2-4
2.2.2 AUTO BACKGROUND CORRECTION .....	2-5
2.2.3 AUTO SHADING .....	2-6
2.2.4 FILTERING AND MAIN SCAN MAGNIFICATION/REDUCTION ....	2-7
Overview.....	2-7
Filtering .....	2-7
Main Scan Magnification/Reduction.....	2-8
2.2.5 BINARY PROCESSING .....	2-8
2.2.6 MEMORY BOARD.....	2-9



2.2.7	THERMAL HEAD.....	2-10
	Specifications.....	2-10
	Thermal Head Control.....	2-10
	Thermal Head Protection.....	2-11
	Remarks for Handling the Thermal Head.....	2-12
2.3	MASTER EJECT .....	2-13
2.3.1	OVERVIEW .....	2-13
2.3.2	MASTER EJECT MECHANISM .....	2-14
	Overview.....	2-14
	Drum Lock Mechanism .....	2-15
	Master Pick-up Roller Drive and Master Clamper Open .....	2-16
	Master Eject and Transportation.....	2-17
	Master Eject Roller Unit Drive.....	2-18
	Master Eject Roller Unit Slide-out Mechanism.....	2-18
	Master Eject Box Mechanism .....	2-19
2.3.3	PRESSURE PLATE DRIVE MECHANISM.....	2-21
	Overview.....	2-21
	Drive .....	2-21
	Homing Operation.....	2-22
	Shift to the Master Eject Position .....	2-23
	Ejected Master Compression.....	2-23
	Master Box Full Detection Mechanism.....	2-24
	Pressure Plate Operation Timing Chart .....	2-25
2.4	MASTER FEED .....	2-26
2.4.1	OVERVIEW .....	2-26
2.4.2	MASTER SET MECHANISM.....	2-27
	Master Roll Set .....	2-27
	Master Feed and Stop Control (Edge Detection) .....	2-27
	Master Buffer Duct Entrance Control .....	2-28
	Master End Detection .....	2-28
2.4.3	MASTER MAKING AND FEED MECHANISM.....	2-29
	Master Feed Mechanism .....	2-29
	Platen Roller Pressure Release.....	2-30
	Master Buffer Mechanism.....	2-31
2.4.4	WRAPPING THE MASTER AROUND DRUM.....	2-32
	Drum Lock and Master Clamper Open .....	2-32
	Master Feed Control Roller Mechanism.....	2-33
	Master Clamping and Wrapping around the Drum.....	2-34
	Master Cut and Buffer Duct Entrance Control.....	2-35
	Cutter Mechanism.....	2-36
2.4.5	MASTER MAKING UNIT SLIDE-OUT MECHANISM .....	2-37
2.4.6	OPENING DOOR FOR MISFED MASTER REMOVAL .....	2-37
2.5	DRUM.....	2-38
2.5.1	OVERVIEW .....	2-38
2.5.2	INK SUPPLY AND KNEADING MECHANISM .....	2-39
	Ink Cartridge Installation .....	2-39
	Ink Supply Mechanism.....	2-39
	Ink Pump Operation Monitoring .....	2-39
	Ink Detection Board .....	2-40

Ink Kneading Mechanism.....	2-42
Drum Idling Mechanism .....	2-43
2.5.3 DRUM SHIFT MECHANISM FOR IMAGE SIDE-TO-SIDE SHIFT .....	2-46
2.5.4 DRUM SET MECHANISM .....	2-47
Upper Handle and Lock .....	2-47
Front Lock Lever .....	2-47
Drum Rotation Lock Mechanism .....	2-47
2.5.5 DRUM DRIVE MECHANISM .....	2-48
2.5.6 MASTER DETECTION .....	2-49
2.6 PAPER FEED.....	2-50
2.6.1 OVERVIEW .....	2-50
Pick-up and Feed.....	2-50
Feed/Separation Pressure .....	2-50
Registration.....	2-50
2.6.2 PAPER FEED MECHANISM .....	2-51
2.6.3 PAPER FEED/SEPARATION PRESSURE ADJUSTMENT MECHANISM .....	2-53
Overview .....	2-53
Paper Separation Pressure.....	2-53
Paper Feed Pressure.....	2-54
Paper Types .....	2-55
PAPER REGISTRATION MECHANISM.....	2-57
Registration Roller Drive .....	2-57
Registration Roller Up/Down Mechanism .....	2-59
2.6.4 PAPER FEED CONTROL MECHANISM.....	2-60
2.6.5 PAPER TABLE ANGLE ADJUSTMENT MECHANISM .....	2-61
2.6.6 PAPER TABLE OPEN DETECTION .....	2-62
2.6.7 PAPER TABLE UP/DOWN MECHANISM .....	2-63
Paper Table Drive Mechanism.....	2-63
Table Upper/Lower Limit Detection and Paper Height Control .....	2-64
2.6.8 PAPER SIDE FENCE MECHANISM .....	2-65
2.6.9 PAPER SIZE AND PAPER END DETECTIONS .....	2-66
2.6.10 PAPER SIDE FENCE LOCK MECHANISM .....	2-67
2.7 PRINTING AND PRESSURE CYLINDER .....	2-68
2.7.1 OVERVIEW .....	2-68
2.7.2 PAPER CLAMPING.....	2-69
Clamping the Paper .....	2-69
Releasing the Paper .....	2-70
2.7.3 PRINTING PRESSURE MECHANISM.....	2-71
2.7.4 PRINTING PRESSURE CAM SHIFTING FOR A3/A4 SIZE MASTERS.....	2-72
2.7.5 PAPER FEED CONTROL MECHANISM.....	2-73
Paper Feed Start Timing Detection.....	2-73
Detection and Feedback of Pressure Cylinder Rotation Fluctuation...	2-73
2.7.6 PRESSURE CYLINDER DRIVE MECHANISM .....	2-74
Overview .....	2-74
Pressure Cylinder HP Return Mechanism (Manual Pressure Cylinder Rotation) .....	2-75
2.7.7 DRUM HOME POSITION DETECTION .....	2-76

PAPER DELIVERY .....	2-77
2.8.1 OVERVIEW .....	2-77
PAPER SEPARATION FROM THE DRUM .....	2-78
Exit Pawl Drive Mechanism .....	2-78
Air Knife Mechanism .....	2-78
2.8.3 PAPER DELIVERY WING MECHANISM .....	2-79
2.8.4 PAPER DELIVERY TABLE MECHANISM.....	2-80
2.8.5 PAPER DELIVERY JAM SENSORS .....	2-81
Paper Delivery Jam.....	2-81
Paper Lower Wrapping .....	2-81
2.8.6 PAPER DELIVERY UNIT DRIVE MECHANISM.....	2-82
2.8.7 JOB SEPARATION MECHANISM.....	2-83
Overview .....	2-83
Sliding Arm Control.....	2-84
2.9 IMAGE UP/DOWN SHIFTING .....	2-85
2.9.1 OVERVIEW .....	2-85
2.9.2 IMAGE UP/DOWN SHIFTING MECHANISM .....	2-86
Shifting Amount Detection .....	2-87
2.10 ERROR DETECTION.....	2-88
2.10.1 ORIGINAL FEED ERROR DETECTION IN THE ADF.....	2-88
2.10.2 MASTER EJECT ERROR DETECTION.....	2-89
Error of Master Pick-up from Drum .....	2-89
Master Eject and Compression Error .....	2-89
2.10.3 ERROR DETECTION DURING MASTER MAKING .....	2-90
Master Set and Feed Error .....	2-90
Master Cut Error .....	2-91
Error During Clamping the Master to the Drum.....	2-91
2.10.4 PAPER FEED ERROR DETECTION .....	2-92
2.10.5 PAPER DELIVERY ERROR DETECTION .....	2-93
Paper Delivery Error .....	2-93
Paper Upper/Lower Wrapping Detection .....	2-93
<b>3. INSTALLATION .....</b>	<b>3-1</b>
3.1 INSTALLATION REQUIREMENTS .....	3-1
3.1.1 REQUIRED ENVIRONMENTAL CONDITIONS .....	3-1
3.1.2 ENVIRONMENTS TO AVOID.....	3-1
3.1.3 POWER CONNECTION.....	3-1
3.1.4 ACCESS TO THE MACHINE .....	3-2
3.2 INSTALLATION PROCEDURE .....	3-3
3.2.1 MAIN BODY .....	3-3
ACCESSORY CHECK.....	3-3
Installation Procedure .....	3-4
3.2.2 PLATEN COVER INSTALLATION (OPTION) .....	3-9
ACCESSORY CHECK.....	3-9
INSTALLATION PROCEDURE .....	3-9
3.2.3 ADF INSTALLATION (OPTION).....	3-10
ACCESSORY CHECK.....	3-10
INSTALLATION PROCEDURE .....	3-11
ADF stabilizer installation.....	3-14

3.2.4 COLOR DRUM (OPTION).....	3-15
--------------------------------	------

<b>4. SERVICE TABLE.....</b>	<b>4-1</b>
4.1 SERVICE REMARKS.....	4-1
4.1.1 SCANNER SECTION.....	4-1
1. Xenon Lamp.....	4-1
2. Scanner Wire Installation.....	4-1
3. Sensor Board Unit (SBU) Calibration.....	4-1
4.1.2 MASTER EJECT SECTION.....	4-1
1. Master Pick-up Roller Drive Gear and Master Clamper Drive Arm Positions.....	4-1
4.1.3 MASTER FEED SECTION.....	4-1
1. Thermal Head 1.....	4-1
2. Thermal Head 2.....	4-1
3. Master Vacuum Fan Position.....	4-1
4. Master Feed Mylar Positions.....	4-2
4.1.4 PAPER FEED SECTION.....	4-2
1. Paper Feed Roller and Paper Separation Roller 1.....	4-2
2. Paper Feed Roller and Paper Separation Roller 2.....	4-2
4.1.5 DRUM AND DRUM DRIVE SECTION.....	4-2
1. Doctor Roller.....	4-2
2. Drum Master Clamper.....	4-2
3. Ink Roller Unit.....	4-2
4.1.6 MAIN DRIVE SECTION.....	4-3
1. Main Drive Adjustment.....	4-3
4.1.7 ELECTRICAL COMPONENTS.....	4-3
1. Main Processing Unit (MPU) and I/O Board.....	4-3
2. Main Processing Unit (MPU) and Power Supply Unit.....	4-3
3. Power Supply Unit.....	4-3
4. Program Update.....	4-3
5. Sensor Adjustments.....	4-3
4.2 DIP SW, LED, VR, TP, AND FUSE TABLES.....	4-4
4.2.1 TEST POINTS.....	4-4
Ink Detection Board.....	4-4
4.2.2 DIP SWITCHES.....	4-4
Ink Detection Board.....	4-4
Operation Panel Board.....	4-4
4.2.3 POTENTIOMETERS.....	4-4
I/O Board.....	4-4
Power Supply Board.....	4-4
Ink Detection Board.....	4-4
4.2.4 LED'S.....	4-5
MPU.....	4-5
I/O Board.....	4-5
4.2.5 FUSES.....	4-5
Power Supply Unit.....	4-5
Main Motor Control Board.....	4-5
4.3 SERVICE CALL CODES.....	4-6
4.4 SPECIAL TOOLS.....	4-15

SERVICE PROGRAM MODE .....	4-16
4.5.1 ACCESS PROCEDURE .....	4-16
Service Program Mode Access Procedure (For Engineers) .....	4-16
Change Adjustment Values or Modes .....	4-17
4.5.1 SERVICE PROGRAM TABLE .....	4-18
1. Data Logging.....	4-18
2. Basic Settings .....	4-23
3. System Settings.....	4-27
4. Input Test Mode .....	4-28
5. Output Test Mode .....	4-31
6. System Adjustment.....	4-35
7. Memory Data Clear.....	4-46
8. System Test.....	4-47
4.5.2 CLEARING THE FACTORY SETTINGS (SP7-1).....	4-49
4.5.3 LOAD PROGRAM (SP8-2).....	4-50
<b>5. PREVENTIVE MAINTENANCE.....</b>	<b>5-1</b>
5.1 MAINTENANCE TABLE .....	5-1
<b>6. REPLACEMENT AND ADJUSTMENT.....</b>	<b>6-1</b>
6.1 EXTERIOR .....	6-1
6.1.1 EXPOSURE GLASS, OPERATION PANEL, AND UPPER COVERS .....	6-1
6.1.2 FRONT DOOR, AND RIGHT FRONT AND RIGHT REAR COVERS .....	6-3
6.1.3 INNER COVER AND KNOB COVER .....	6-4
6.2 COPY IMAGE ADJUSTMENT.....	6-5
6.2.1 LEADING EDGE REGISTRATION ADJUSTMENT .....	6-5
6.2.2 SIDE-TO-SIDE REGISTRATION ADJUSTMENT .....	6-6
6.2.3 VERTICAL MAGNIFICATION ADJUSTMENT.....	6-7
6.3 MPU AND I/O BOARD REPLACEMENT.....	6-8
6.4 MPU AND PSU OPENING PROCEDURES.....	6-9
Opening the MPU .....	6-9
Opening the PSU .....	6-9
6.5 SCANNER UNIT.....	6-10
6.5.1 LENS COVER .....	6-10
6.5.2 SCANNER FRAME.....	6-11
6.5.3 ORIGINAL SIZE SENSOR, LENS BLOCK/SBU ASSEMBLY AND LAMP STABILIZER .....	6-12
Original Size Sensors .....	6-12
Lens Block/SBU Assembly .....	6-13
Lamp Stabilizer .....	6-14
6.5.4 XENON LAMP .....	6-15
6.5.5 SCANNER H. P. SENSOR/PLATEN COVER SENSOR .....	6-16
6.5.6 SCANNER MOTOR.....	6-17
6.5.7 SCANNER WIRE.....	6-18
6.5.8 SENSOR BOARD UNIT CALIBRATION.....	6-21

6.6	MASTER EJECT SECTION .....	6-22
6.6.1	MASTER EJECT ROLLER UNIT .....	6-22
	Unit Removal .....	6-22
	Master Eject Sensor.....	6-22
6.6.2	MASTER EJECT DRIVE UNIT .....	6-23
	Unit Removal .....	6-23
	Sensors and Motors in the Master Eject Drive Unit .....	6-24
6.6.3	MASTER EJECT SENSOR ADJUSTMENT .....	6-25
6.6.4	REASSEMBLING THE MASTER PICK-UP ROLLER DRIVE GEARS.....	6-26
6.7	MASTER FEED SECTION .....	6-27
6.7.1	MASTER MAKING UNIT REMOVAL.....	6-27
6.7.2	MASTER SET ROLLER AND PLATEN ROLLER.....	6-28
6.7.3	THERMAL HEAD.....	6-30
6.7.4	SENSORS, MOTORS, AND CUTTER IN THE MASTER MAKING UNIT 6-31	
	Duct Entrance Solenoid .....	6-31
	Cutter Unit, Platen Release Motor and Sensor, and Master Feed Clutch .....	6-33
	Master Feed Motor.....	6-36
	Master Set Sensor .....	6-38
	Master End Sensor .....	6-39
6.7.5	MASTER VACUUM FAN POSITIONING.....	6-40
6.7.6	THERMAL HEAD VOLTAGE ADJUSTMENT.....	6-41
6.7.7	MASTER END SENSOR ADJUSTMENT .....	6-42
6.7.8	MASTER EDGE SENSOR ADJUSTMENT .....	6-43
6.7.9	PLATEN RELEASE CAM ADJUSTMENT .....	6-45
6.7.10	MASTER FEED MYLAR POSITIONING .....	6-46
6.8	DRUM.....	6-47
6.8.1	DRUM CLOTH SCREEN.....	6-47
6.8.2	DRUM MASTER CLAMPER AND METAL SCREEN .....	6-49
6.8.3	MOTORS AND SENSORS IN THE DRUM .....	6-51
6.8.4	QUALITY BLADE .....	6-54
6.8.5	FIRST DRUM MASTER SENSOR ADJUSTMENT.....	6-55
6.8.6	SECOND DRUM MASTER SENSOR ADJUSTMENT.....	6-56
6.8.7	INK ROLLER GAP ADJUSTMENT.....	6-58
6.8.8	INK DETECTION ADJUSTMENT.....	6-59
6.9	PAPER FEED SECTION.....	6-60
6.9.1	PAPER TABLE UNIT.....	6-60
6.9.2	PAPER FEED ROLLER, PICK-UP ROLLER, AND FRICTION PAD6-61	
6.9.3	PAPER WIDTH DETECTION BOARD .....	6-62
6.9.4	PAPER HEIGHT SENSOR.....	6-62
6.9.5	FEED PRESSURE DETECTION BOARD .....	6-63
6.9.6	PAPER REGISTRATION AND FEED TIMING SENSORS, AND UPPER REGISTRATION ROLLER .....	6-64
6.9.7	LOWER REGISTRATION ROLLER .....	6-68
6.9.8	REGISTRATION ROLLER LIFTING CAM REMOVAL .....	6-69
6.9.9	REGISTRATION ROLLER LIFTING CAM POSITION ADJUSTMENT .....	6-70

6.9.10	PAPER TABLE HEIGHT ADJUSTMENT.....	6-71
6.9.11	TIMING BELT TENSION ADJUSTMENT FOR THE PAPER FEED MOTOR.....	6-72
6.9.12	TIMING BELT TENSION ADJUSTMENT FOR THE REGISTRATION MOTOR .....	6-73
6.9.13	PAPER FEED AND SEPARATION PRESSURE ADJUSTMENT.....	6-74
	Paper feed pressure adjustment.....	6-74
	Paper separation pressure adjustment .....	6-75
6.9.14	PAPER FEED LENGTH ADJUSTMENT .....	6-76
	Paper Feed Motor Stop Timing Adjustment.....	6-76
	Paper Clamping Timing Adjustment .....	6-77
6.10	PRINTING SECTION .....	6-78
6.10.1	PRESSURE CYLINDER.....	6-78
	Removal Procedure .....	6-78
	Reinstallation procedure .....	6-81
6.10.2	FEED START SENSOR AND FEED ENCODER .....	6-84
6.10.3	PRINTING PRESSURE ADJUSTMENT.....	6-85
6.10.4	PRINTING PRESSURE RELEASE ARM GAP ADJUSTMENT ...	6-86
6.11	MAIN DRIVE AND IMAGE UP/DOWN SHIFTING DRIVE SECTION....	6-87
6.11.1	MAIN MOTOR AND TORQUE LIMITER .....	6-87
	Removal procedure .....	6-87
	Reinstallation procedure .....	6-91
6.11.2	MAIN DRIVE MECHANISM (MAIN DRIVE TIMING BELT) .....	6-92
	Disassembly Procedure.....	6-93
	Reassembly Procedure.....	6-98
	Copy Image Check Procedure after Main Drive and Image Up/Down Shifting Drive Section Re-assembly .....	6-108
6.11.3	PRESSURE CYLINDER ROTATION KNOB ADJUSTMENT .....	6-109
6.11.4	SCISSORS GEAR POSITION ADJUSTMENT.....	6-110
6.11.5	IMAGE UP/DOWN SHIFT WORM-GEAR POTISION ADJUSTMENT	6-111
6.11.6	IMAGE UP/DOWN SHIFT DRIVE UNIT POSITION ADJUSTMENT	6-112
6.12	PAPER DELIVERY SECTION.....	6-113
6.12.1	PAPER DELIVERY UNIT AND AIR KNIFE FAN UNIT .....	6-113
6.12.2	PAPER EXIT SENSOR AND TRANSPORT VACUUM FAN REMOVAL.....	6-114
6.12.3	PAPER TRANSPORT BELT REMOVAL .....	6-115
6.12.4	PAPER EXIT PAWL REMOVAL.....	6-116
6.12.5	GAP ADJUSTMENT BETWEEN PAPER PICK-OFF PLATE AND PRESSURE CYLINDER.....	6-117
6.12.6	PAPER EXIT PAWL DRIVE TIMING ADJUSTMENT .....	6-118
6.12.7	GAP ADJUSTMENT BETWEEN EXIT PAWL AND DRUM .....	6-119

<b>7. POINT TO POINT DIAGRAM .....</b>	<b>7-1</b>
LOCATION MAP	
SECTION A	
SECTION B	
SECTION C	
SECTION D	
SECTION E	
SECTION F	
SECTION G	
SECTION H	

## OPTION

### DOCUMENT FEEDER (C600)

<b>1. OVERALL INFORMATION .....</b>	<b>C600-1</b>
1.1 SPECIFICATIONS.....	C600-1
1.2 MECHANICAL COMPONENT LAYOUT .....	C600-2
1.3 ELECTRICAL COMPONENT LAYOUT .....	C600-3
1.4 ELECTRICAL COMPONENT DESCRIPTION.....	C600-4
1.5 DRIVE LAYOUT .....	C600-5
<b>2. DETAILED SECTION DESCRIPTIONS .....</b>	<b>C600-6</b>
2.1 ORIGINAL SIZE DETECTION.....	C600-6
2.2 PICK-UP AND SEPARATION .....	C600-8
2.3 ORIGINAL TRANSPORT AND EXIT MECHANISM .....	C600-9
2.4 OVERALL ELECTRICAL CIRCUIT .....	C600-10
<b>3. REPLACEMENT AND ADJUSTMENT.....</b>	<b>C600-11</b>
3.1 FEED UNIT REMOVAL .....	C600-11
3.2 SEPARATION ROLLER REPLACEMENT .....	C600-11
3.3 PICK-UP ROLLER REPLACEMENT .....	C600-12
3.4 FEED BELT REPLACEMENT .....	C600-12
3.5 ORIGINAL SET SENSOR REPLACEMENT .....	C600-13
3.6 ORIGINAL WIDTH/LENGTH/TRAILING EDGE SENSOR REPLACEMENT .....	C600-14
3.7 ORIGINAL EXIT TRAY/FRONT COVER/REAR COVER REMOVAL	C600-15
3.8 FEED COVER OPEN SENSOR/DF OPEN SENSOR REPLACEMENT .....	C600-15
3.9 FEED CLUTCH/PICK-UP SOL/TRANSPORT MOTOR REPLACEMENT .....	C600-16
3.10 DF FEED COVER REMOVAL.....	C600-17
3.11 REGISTRATION SENSOR REPLACEMENT.....	C600-17



# 1. OVERALL INFORMATION

## 1.1 ESSENTIAL DIFFERENCES BETWEEN C235 AND C235 MODELS

No.	Item	Remarks
1	New ink and master	New supplies for 600 dpi are used in this model.
2	Master Feed Control Motor	Improves master feed reliability by using a motor in the master making unit (the master feed control motor) instead of the master feed clutch.
3	Anti-Static Roller	An anti-static roller is used in the master making unit instead of an anti-static brush. This prevents master misfeeds and is more effective for removing static electricity.
4	Master Detection	The sensor patch extends across the entire width of the drum. This helps to prevent damage to the sapphire master, which is more delicate than the Pearl master.
5	Quality Blade	The quality blade has been added. This ensures that the first print has sufficient ink density even if the machine was not used for a long time.
6	Ink Detection Pin	The ink detection pin has been redesigned to improve its effectiveness.
7	New Metal Screen and Cloth Screen	The single drum screen and the high-density metal screen helps to spread ink evenly, which is effective for producing an even print quality.
8	Separation Pad	The most suitable separation pad for the paper type is automatically selected. This improves the paper feed reliably for all the paper types.
9	Side Fence Lock Lever	The side fence lock levers have been added to the side fences on the paper feed table. They ensure correct paper positioning for better paper feed.
10	Paper Feed Table	The paper feed tray can be extended for large paper sizes. The extension can be pulled out easily from the edge of the paper feed table.
11	Paper Clamper	A newly designed paper clamper is used. Paper can be clamped in thick paper mode with this model.
12	Paper Delivery Unit	A newly designed paper delivery unit is used. The material and shape of the paper pick-off plate at the paper delivery unit have been changed to improve paper delivery.
13	Paper Delivery Table	A newly designed paper delivery table is used. The paper delivery table of this model can be folded.

No.	Item	Remarks
14	Document Feeder	A newly designed document feeder is used.
15	Scanner Unit	A newly designed scanner unit is used.
16	PSU, MPU, I/O Board, Thermal Head, Memory Board	<p>The thermal head power supply board is not used. The function of the thermal head power supply board is included in the PSU. The thermal head voltage adjustment is adjusted on the PSU.</p> <p>A newly designed MPU is used. The interface board is not used. The function of the interface board is included in the MPU.</p> <p>A newly designed I/O Board is used. The job separation board is not used. The function of the job separation board is included in the I/O board.</p> <p>A newly designed thermal head for 600 dpi is used.</p> <p>The C235 model includes the memory board as standard equipment.</p>

**1.2 SPECIFICATIONS**

Configuration:	Desktop	
Master Processing:	Digital with 600 dpi thermal head	
Scanning (Pixel Density):	600 dpi CCD	
Printing Process:	Fully automatic stencil system, with one drum and pressure cylinder	
Original Type:	Sheet/Book	
In Platen Mode:	Document size: Maximum 304.8 x 432 mm [12.0" x 17.0"]  Thickness: Less than 30 mm  Weight: 10 kg	
In ADF Mode:	Document size: Maximum 297 x 864 mm [11.6" x 33.8"] Minimum 148 x 210 mm [5.8" x 8.2"]  Document weight: 40 - 128 g/m <sup>2</sup> [10 - 34 lb]  ADF capacity: 50 sheets (using 22 lb or 80 g/m <sup>2</sup> paper)	
Reproduction Ratios:	<u>Inch versions</u>	<u>Others</u>
Full Size:	100%	100%
Reduction:	65% 74% 77% 93%	71% 82% 87% 93%
Enlargement:	121% 129% 155%	115% 122% 141%
Zoom:	50 - 200% (by 1%) in Platen mode 50 - 200% (by 1%) in ADF mode	
Directional Magnification:	50 - 200% (by 1%)	
Image Modes:	Letter, Letter/Photo, Photo, Pencil, Tint	

Printing Area: (At 20 °C/ 65 % RH)	Metric size version models: 290 mm x 410 mm  Inch size version models: 290 mm x 420 mm [11.4" x 16.5"]  With optional A4 drum: 290 mm x 204 mm [11.4" x 8.0"]
Edge Margins:	Leading edge: 8 mm (At the "0" position of Image Shift mode)  Trailing edge: 2 mm
Print Paper Size:	Minimum: 70 mm x 148 mm [2.8" x 5.9"] Maximum: 325 mm x 447 mm [12.7" x 17.6"]
Print Paper Weight:	47.1 g/m <sup>2</sup> to 209.3 g/m <sup>2</sup> [12.5 lb to 55.6 lb]
Printing Speed:	60, 75, 90, 105, 120 sheets/minute (5 steps)
Master Process Time:	Platen mode: Less than 31 seconds (A3 paper) Less than 25 seconds (A4 paper)  ADF mode: Less than 34 seconds (A3 paper) Less than 28.5 seconds (A4 paper)
Master Eject Box Capacity:	70 masters, A3 size (Normal conditions)
Side Registration Adjustable Range:	± 10 mm
Vertical Registration Adjustable Range:	Inch size version models: ± 10 mm  Metric size version models: ± 15 mm
Paper Feed Table Capacity:	1000 sheets (80 g/m <sup>2</sup> , 20 lb)
Paper Delivery Table Capacity:	1000 sheets (80 g/m <sup>2</sup> , 20 lb)
Power Source:	110/120 V, 50/60 Hz: 2.5 A 220 - 240 V, 50/60 Hz: 1.5 A
Maximum Power Consumption:	110/120 V version: 260 W 220 - 240 V version: 240 W

Noise Emission: (At operation position)	At 60 rpm printing speed: 58 dB At 90 rpm printing speed: 61 dB At 120 rpm printing speed: 64 dB
Weight:	105 kg [231 lb] 114 kg [251 lb] with ADF
Dimensions: (Width x Depth x Height)	Trays closed: 625 mm x 700 mm x 574 mm With ADF: 625 mm x 700 mm x 684 mm Trays open: 1405 mm x 700 mm x 574 mm With ADF: 1405 mm x 700 mm x 684 mm
Master Type:	Thermal master roll type: 320 mm width, 140 m/roll Yield: 255 masters/roll (at A3 size) Max run length per master: 2,000 prints
Master Storage Conditions:	Temperature: 0 °C to 40 °C Humidity: 10% to 95% RH Recommended maximum storage period: One year after production date Note: Avoid locations exposed to direct sunlight.
Ink Type	1000 ml cartridge type Available colors: Black, Red, Blue, Green, Brown, Purple, Yellow, Navy, Maroon, Teal, Orange, Gray, Violet, Hunter green, Burgundy, Gold

Ink Storage Conditions:

Temperature:

-5 °C to 40 °C

(Optimum conditions: 15 °C to 25 °C)

Humidity:

10% to 95% RH

(Optimum conditions: 20% to 70% RH)

Recommended maximum storage period:

18 month after production date

Note: Avoid locations exposed to direct sunlight.

Available Options

- A3 Drum
- A4 Drum
- Document Feeder
- Key Counter
- PC Controller
- Sorter
- Platen Cover

## 1.3 GUIDE TO COMPONENTS AND THEIR FUNCTIONS

### 1.3.1 MACHINE EXTERIOR

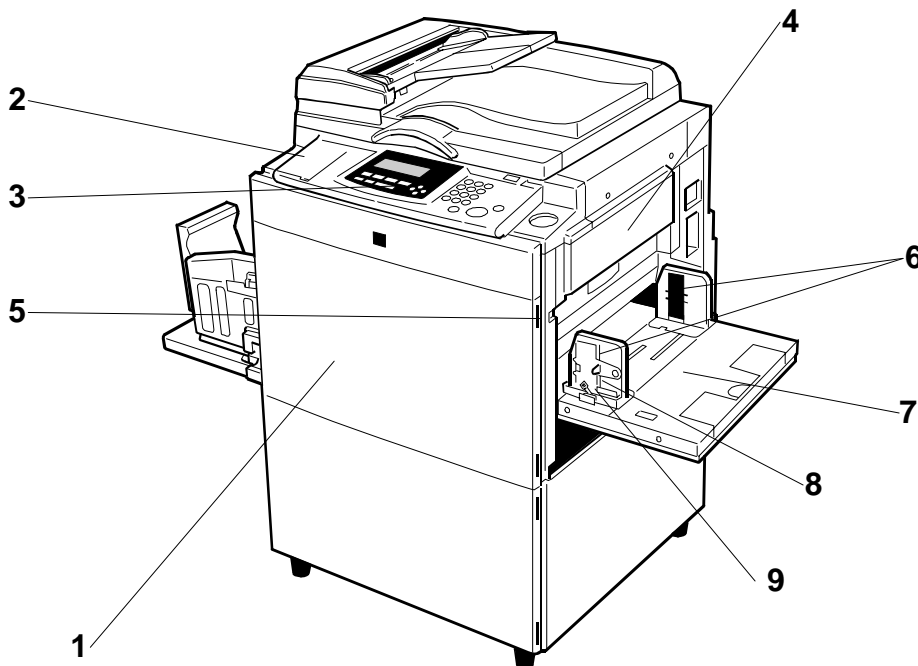

C235V515.WMF

- |   |   |
|---|---|
| <b>1. Front Door</b>                        | Open for access to the inside of the machine.         |
| <b>2. Flip-up Cover</b>                     | Open to access the Image Density key and other keys.  |
| <b>3. Operation Panel</b>                   | Operator controls and indicators are located here.    |
| <b>4. Master Feed Unit</b>                  | Open the master feed unit when installing the master. |
| <b>5. Paper Feed Tray Down Key</b>          | Press to lower the paper feed tray.                   |
| <b>6. Paper Feed Side/End Plates</b>        | Use to prevent paper skew.                            |
| <b>7. Paper Feed Tray</b>                   | Set paper on this tray for printing.                  |
| <b>8. Paper Feed Side Plate Knob</b>        | Use to move the side plates.                          |
| <b>9. Paper Feed Side Plates Lock Lever</b> | Use this to secure the paper feed side plates.        |

# 1.4 MACHINE INTERIOR

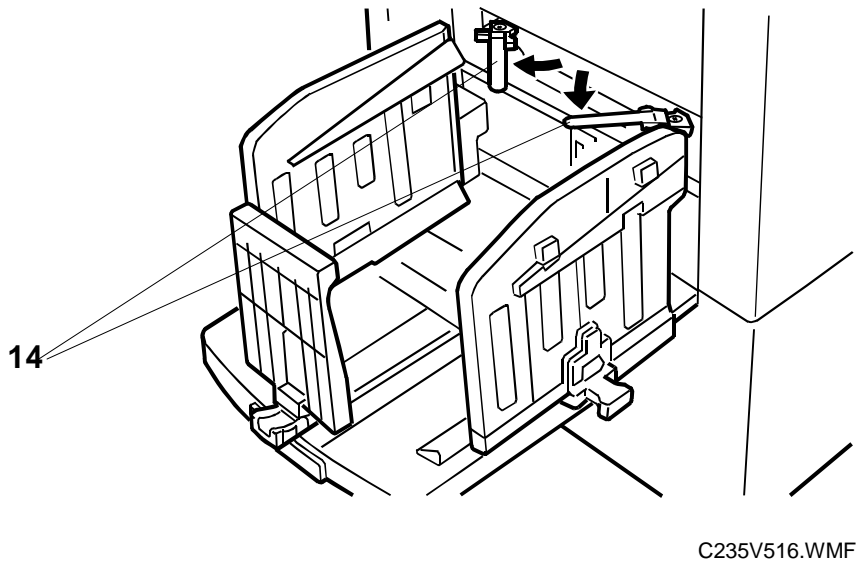
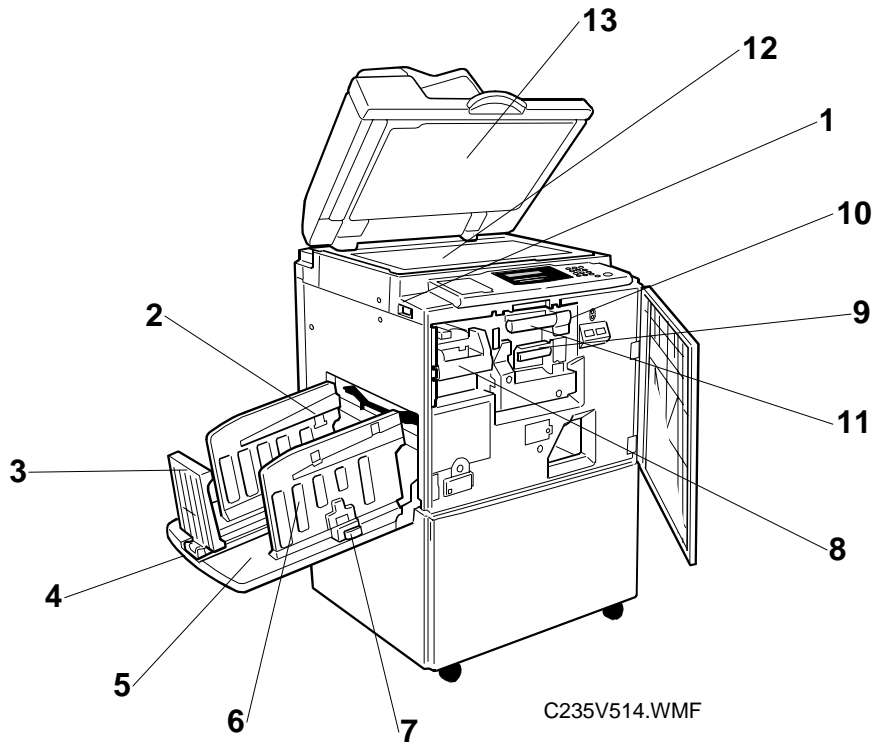



1. **Main Switch** Use to turn the power on or off.
2. **Paper Alignment Wings** Lift or lower the wings depending on the paper type you use.
3. **Paper Delivery End Plate** This plate aligns the leading edges of prints.
4. **Paper Delivery End Plate Knob** Use to move the end plate.
5. **Paper Delivery Tray** Completed prints are delivered here.
6. **Paper Delivery Side Plates** These plates align the prints on the paper delivery tray.
7. **Paper Delivery Side Plate Knobs** Use to move the side plates.
8. **Master Eject Unit Front Handle E1** Use to pull out the master eject unit.
9. **Ink Holder** Set the ink cartridge in this holder.
10. **Drum Unit Lock Lever B1** Lower to unlock and pull out the drum unit.
11. **Drum Unit** The master is wrapped around this unit.
12. **Exposure Glass** Position originals here face down for printing.
13. **Platen Cover** Lower this cover over an original before printing.
14. **Trailing Edge Guides** Swing out these guides when you use A4, 8 1/2" x 11" sideways, or B5 lengthwise paper.

### 1.4.1 OPERATION PANEL

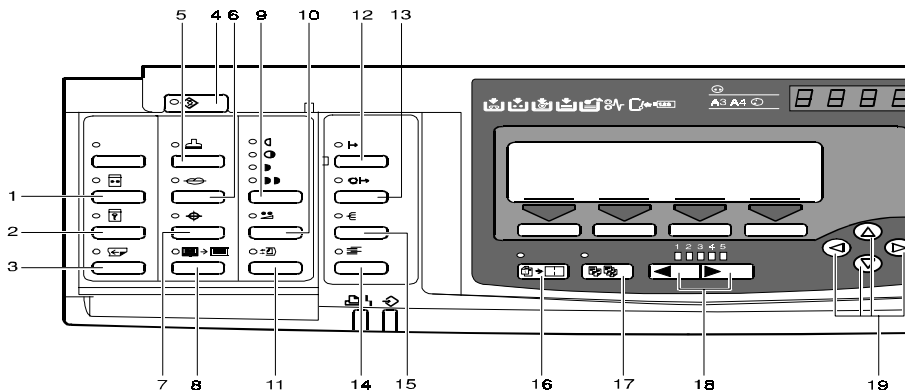

C235V517.WMF

- |  |   |
|--|---|
| <ul style="list-style-type: none"> <li><b>1. Quality Start key</b></li> <li><b>2. Security key</b></li> <li><b>3. Skip Feed key</b></li> <li><b>4. User Tools key</b><br/>Press to change the default settings and conditions to meet your requirements.</li> <li><b>5. Stamp key</b></li> <li><b>6. Make-up key</b></li> <li><b>7. Overlay key</b></li> <li><b>8. Edge Erase key</b></li> <li><b>9. Image Density key</b><br/>Press to make prints darker or lighter.</li> <li><b>10. Economy Mode key</b></li> </ul> | <ul style="list-style-type: none"> <li><b>11. Original Storage Key</b></li> <li><b>12. On Line key</b></li> <li><b>13. Auto On Line Key</b></li> <li><b>14. Job Separator key</b></li> <li><b>15. Sorter Key</b></li> <li><b>16. Combine key</b><br/>Press to combine originals onto one print.</li> <li><b>17. Class key</b><br/>Press to select All Class, Auto Class, Manual Class, or Class mode.</li> <li><b>18. Speed keys</b></li> <li><b>19. Scroll keys</b><br/>Press to shift the image forward, backward, right, or left.</li> </ul> |
|--|---|

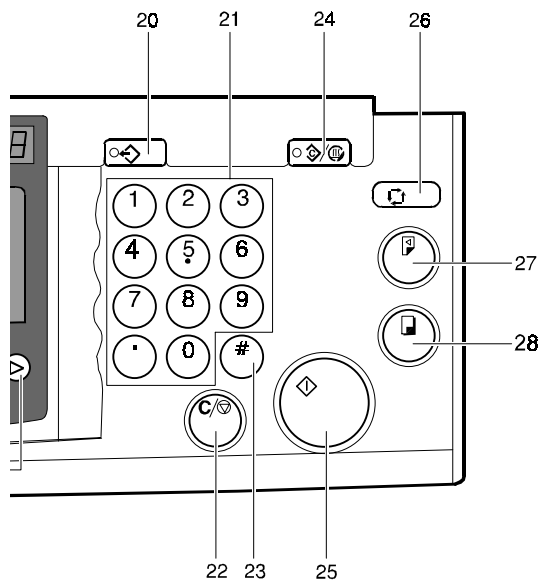

C235V502.WMF

**20. Program key**

Press to input or recall user programs.

**21. Number keys****22. Clear/Stop key**

While printing, press to stop the machine.

**23. Enter key**

Use to store data that has been entered in the selected mode.

**24. Clear Modes/Energy Saver key**

Press to clear any previously entered job settings.

**25. Start key**

Press to make a master.

**26. Auto Cycle key**

Use to process the master and make prints at one stroke.

**27. Proof key**

Press to make a proof print.

**28. Print key**

Press to start printing.

### 1.4.2 INDICATORS

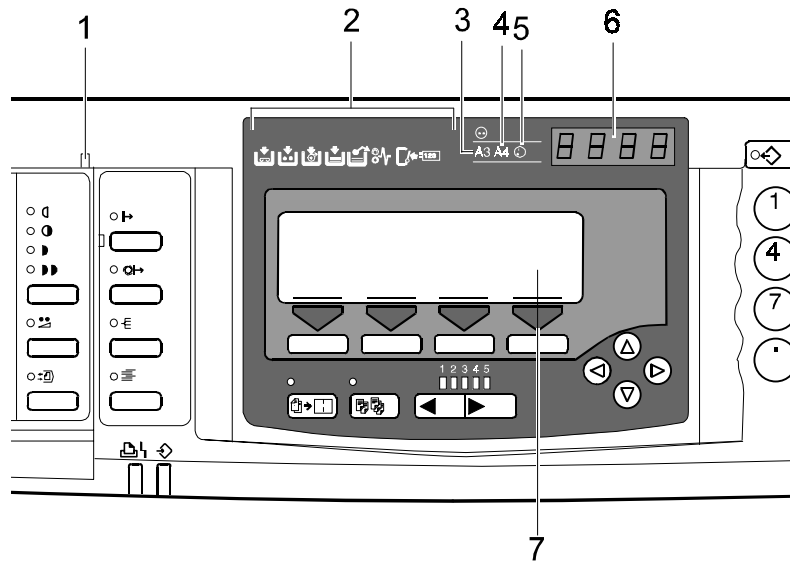

C235V518.WMF

#### 1. Special Feature indicator

This indicator is lit when you press keys under the flip-up cover.

#### 2. Monitors

The monitors light up when an abnormal condition occurs within the machine.

#### 3. A3/11" x 17" Drum indicator

This indicator is lit when the A3 [11" x 17"] drum unit is installed.

#### 4. A4/8 1/2" x 11" Drum indicator

This indicator is lit when the A4 [8.5" x 11"] drum unit is installed.

#### 5. Color Drum indicator

This indicator is lit when a color drum unit is installed.

#### 6. Counter

Displays the number of prints entered. While printing, it shows the number of prints remaining.

#### 7. Panel Display

## 1.5 PRINTING PROCESS OVERVIEW

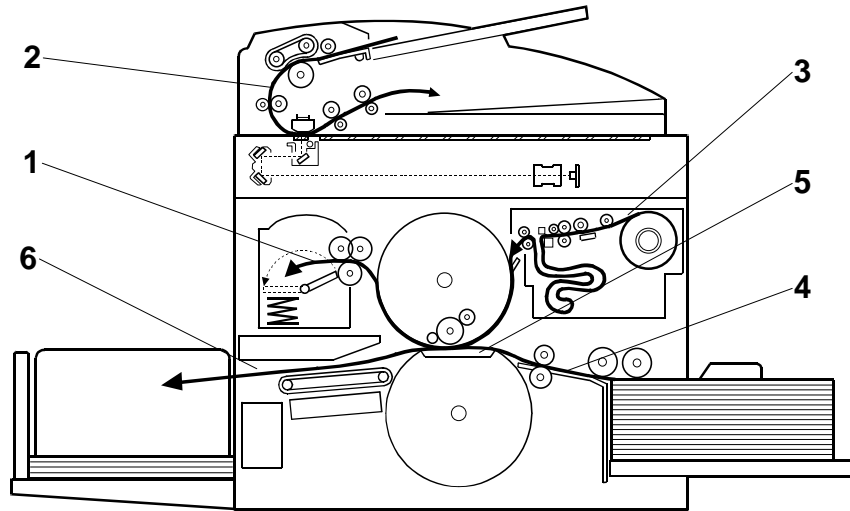

C235V502.WMF

- |  |  |
|--|--|
| <p>1. Master Ejecting:</p> <p>↓</p> <p>2. Scanning:</p> <p>↓</p> <p>3. Master Feeding:</p> <p>↓</p> <p>4. Paper Feeding:</p> <p>↓</p> <p>5. Printing:</p> <p>↓</p> <p>6. Paper Delivering:</p> | <p>Ejects the used master wrapped around the drum into the master eject box.</p> <p>Scans the original image with the CCD through the mirrors and the lens.</p> <p>Converts the image signal read by the CCD into digital signals and sends them to the thermal head to develop the image on the master. The master then wraps around the drum.</p> <p>Sends paper to the drum section.</p> <p>Presses the paper fed from the paper feed section against the drum. This transfers ink to the paper through the drum screen and the master.</p> <p>Peels off the printed paper with the exit pawls and air knife, and ejects the paper onto the paper delivery table.</p> |
|--|--|

Some parts of the master eject, scanning, and master feeding processes are carried out at the same time. Paper feeding also starts before the master feeding process has finished.

## 1.6 MECHANICAL COMPONENT LAYOUT

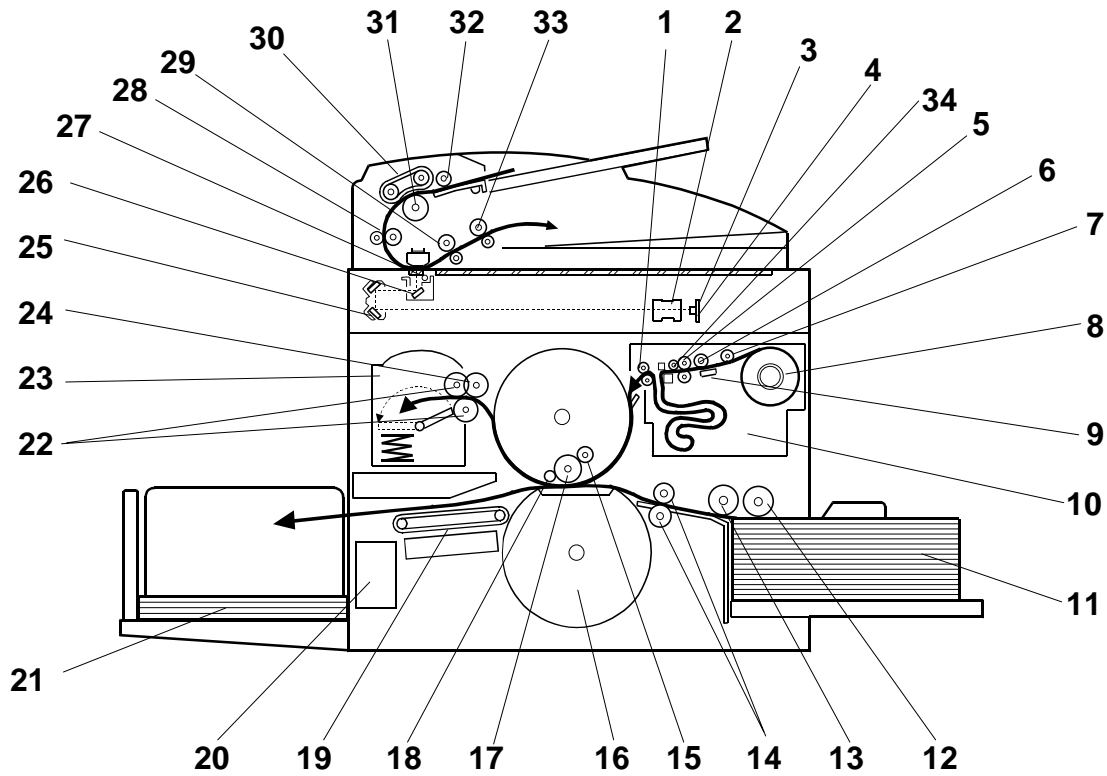

C235V502.WMF

- |                               |                           |
|-------------------------------|---------------------------|
| 1. Master Feed Control Roller | 18. Idling Roller         |
| 2. Lens                       | 19. Transport Belts       |
| 3. CCD                        | 20. Job Separator Unit    |
| 4. SBU                        | 21. Paper Delivery Table  |
| 5. Tension Roller             | 22. Master Eject Rollers  |
| 6. Platen Roller              | 23. Master Eject Box      |
| 7. Master Set Roller          | 24. Master Pick-up Roller |
| 8. Master Roll                | 25. 2nd Scanner           |
| 9. Thermal Head               | 26. 1st Scanner           |
| 10. Master Buffer Duct        | 27. DF Exposure Glass     |
| 11. Paper Table               | 28. 1st Transport Roller  |
| 12. Paper Feed Roller         | 29. 2nd Transport Roller  |
| 13. Paper Separation Roller   | 30. Original Feed Belt    |
| 14. Registration Rollers      | 31. Separation Roller     |
| 15. Doctor Roller             | 32. Pick-up Roller        |
| 16. Pressure Cylinder         | 33. Original Exit Roller  |
| 17. Ink Roller                | 34. Anti-static Roller    |

# 1.7 ELECTRICAL COMPONENT LAYOUT

## 1.7.1 PRINTED CIRCUIT BOARD LAYOUT

Overall Information

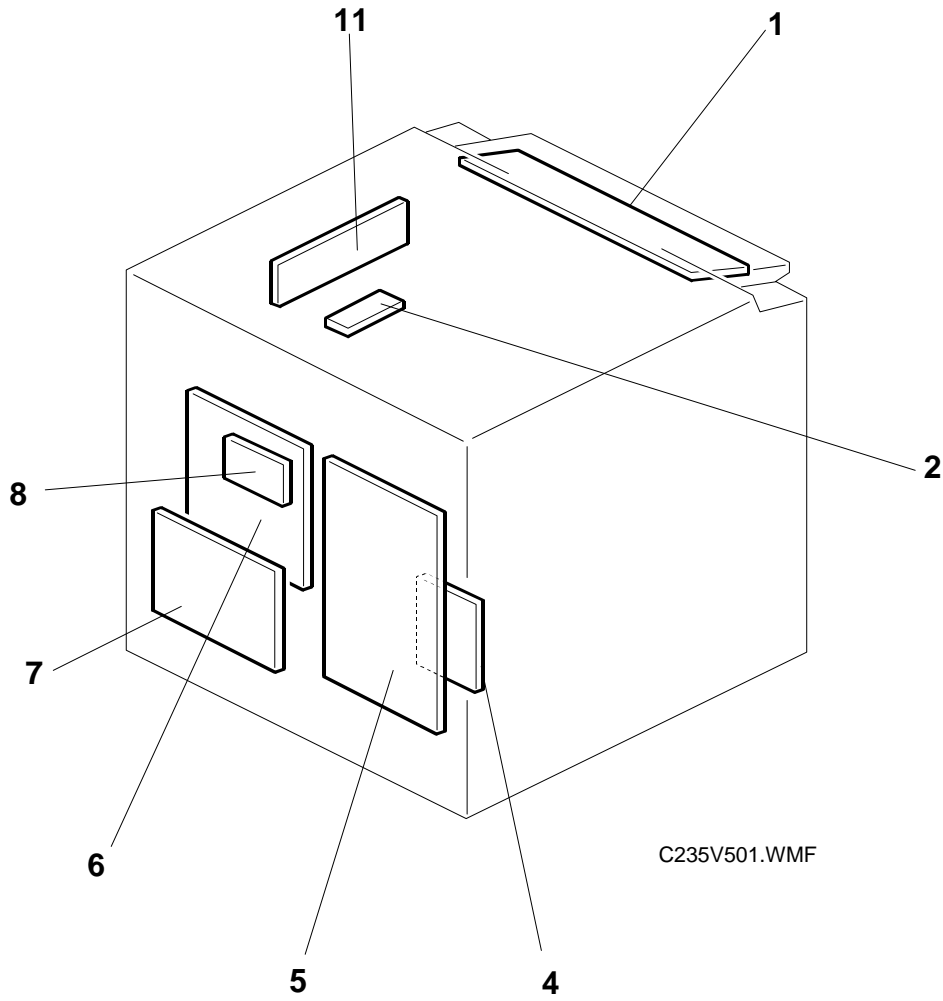

### 1.7.2 SCANNER SECTION

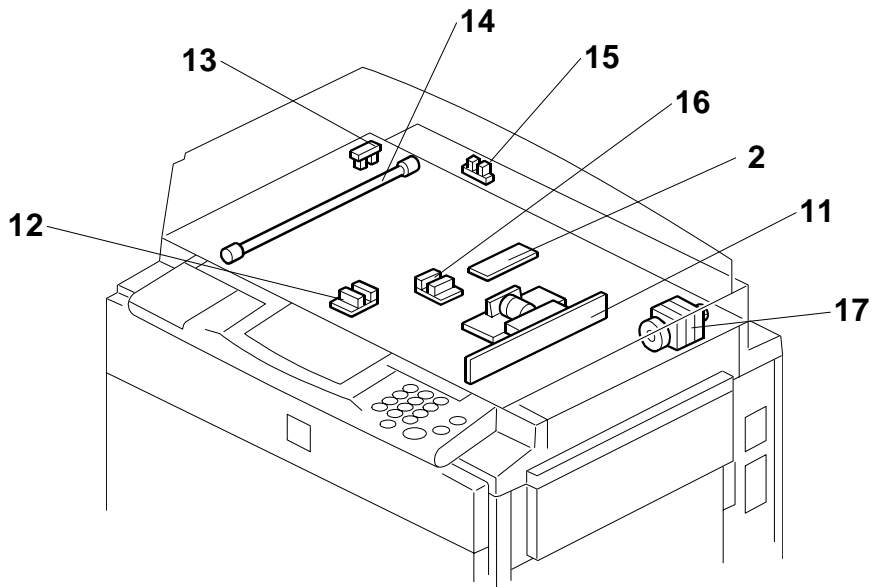

C235V509.WMF

### 1.7.3 PAPER FEED SECTION

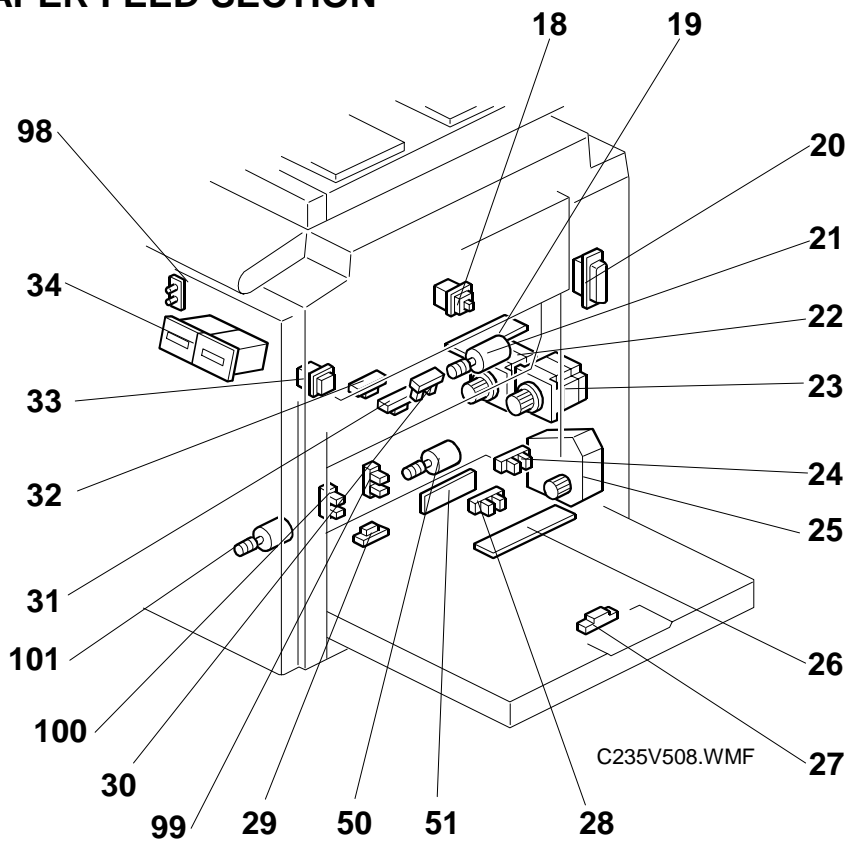

C235V508.WMF



### 1.7.4 MASTER EJECT, PRESSURE CYLINDER, AND OTHER SECTIONS

Overall Information

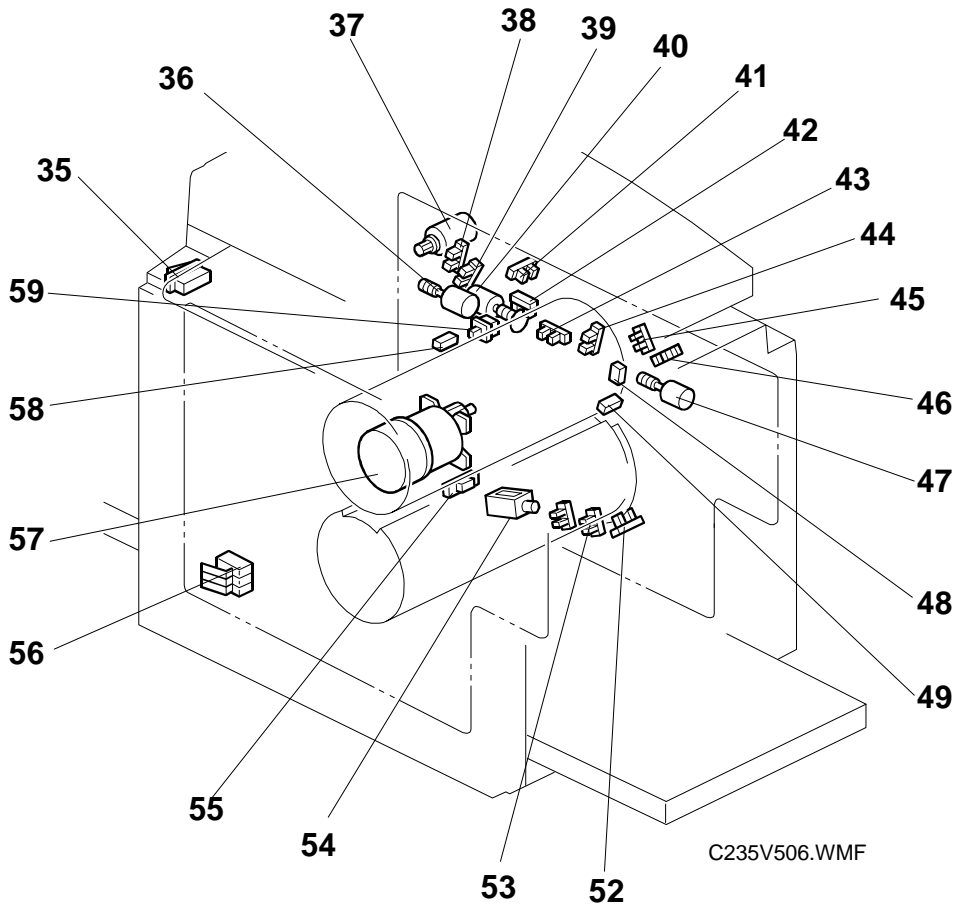

### 1.7.5 PAPER DELIVERY SECTION

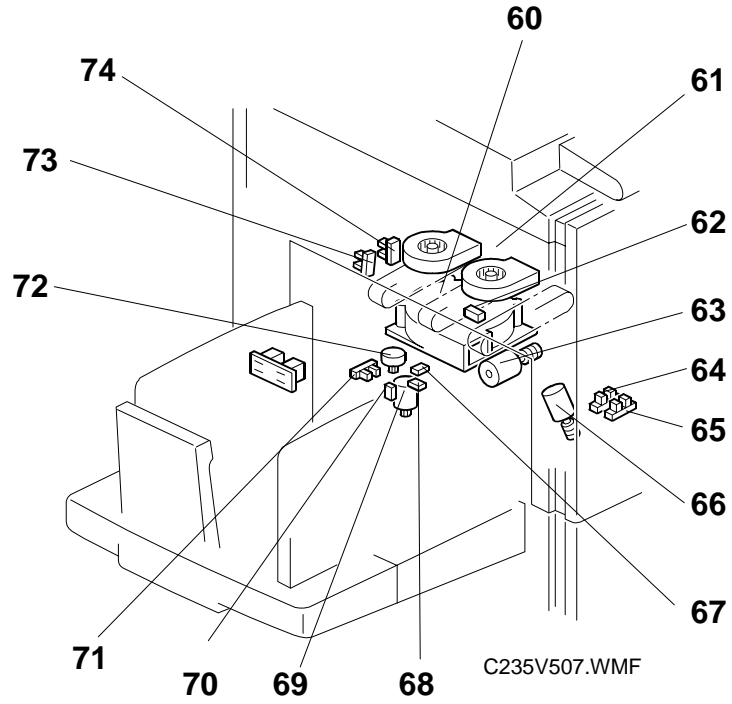

### 1.7.6 MASTER MAKING UNIT

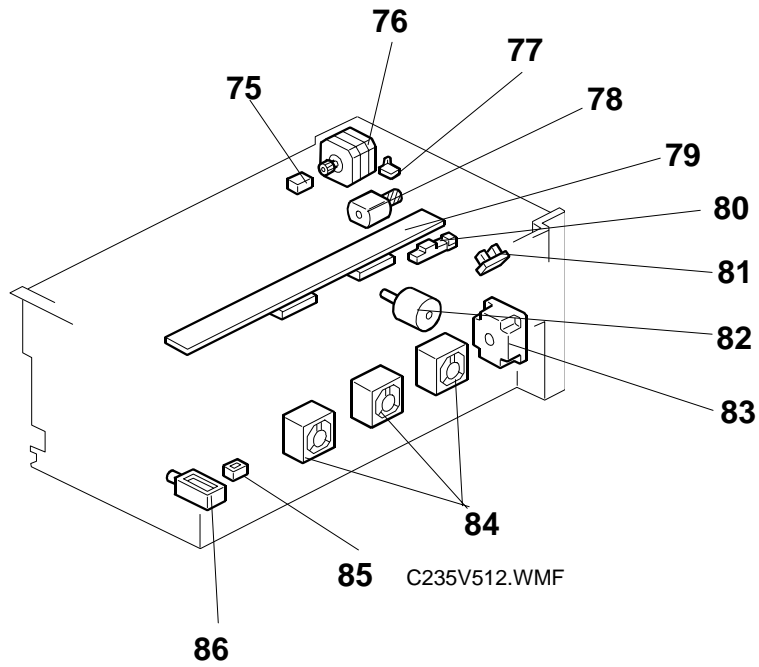

### 1.7.7 DRUM UNIT

Overall  
Information

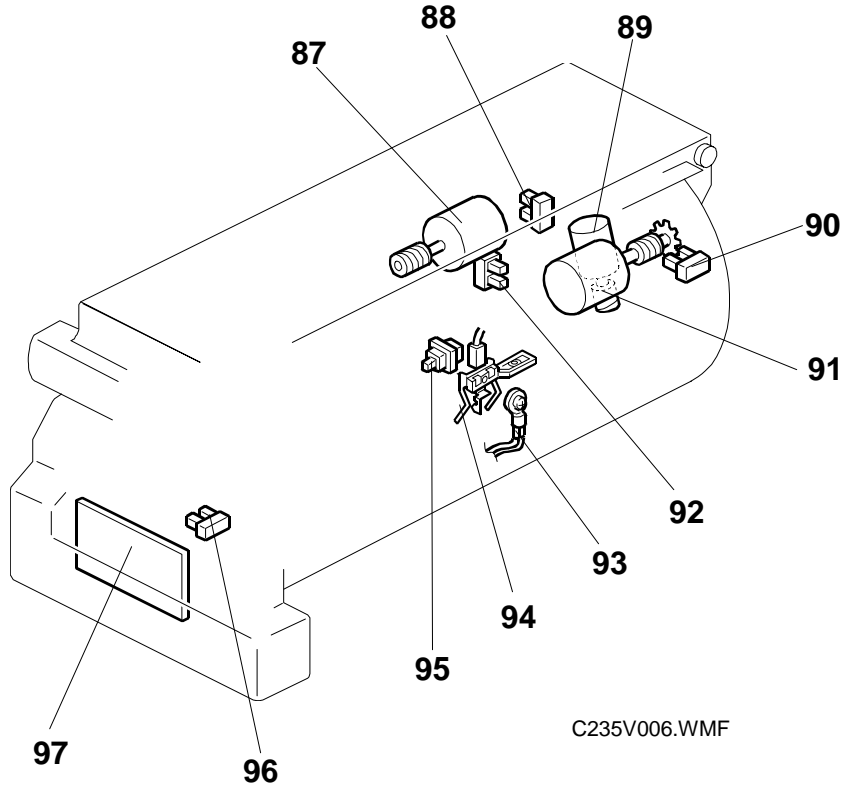

## 1.7.8 TABLES OF ELECTRICAL COMPONENTS

### **Boards**

<b>Index No.</b>	<b>Name</b>	<b>Function</b>
1	Operation Panel Board	Controls the operation panel.
2	Lamp Stabilizer	Provides dc power for the xenon lamp.
4	Main Motor Control Board	Controls the main motor.
5	Power Supply Unit (PSU)	Provides dc power to the system.
6	Main Processing Unit (MPU)	Controls all machine functions both directly and through other boards.
7	I/O Board	Controls the mechanical components.
8	Memory Board	Enables the image editing function and data printout via SP mode.
11	Sensor Board Unit (SBU)	Contains the CCD, and outputs a video signal to the MPU.
19	Feed Pressure Detection Board	Sends data about the paper feed pressure to the CPU.
26	Paper Width Detection Board	Sends data about the paper width on the paper table to the CPU.
51	Separation Pressure Detection Board	Sends data about the paper separation pressure to the CPU.
97	Ink Detection Board	Checks if there is ink in the drum.

### **Solenoids**

<b>Index No.</b>	<b>Name</b>	<b>Function</b>
54	Printing Pressure Release Solenoid	There are two solenoids: one at the front and one at the rear. They pull the release arms to apply the printing pressure against the drum.
86	Duct Entrance Solenoid	Opens or closes the plate at the entrance of the master buffer duct.

### **Switches**

<b>Index No.</b>	<b>Name</b>	<b>Function</b>
33	Paper Table Lowering Switch	Lowers the paper table.
35	Main Switch	Turns the power on or off.
56	Cover Safety Switches	Checks if the front door is set correctly.

**Motors**

Index No.	Name	Function
17	Scanner Drive Motor	Drives the scanner.
21	Feed Pressure Motor	Drives the paper feed pressure adjustment mechanism.
22	Registration Motor	Feeds the paper to align it with the image on the master on the drum.
23	Paper Feed Motor	Feeds the paper from the paper table.
25	Paper Table Motor	Raises and lowers the paper table.
36	Pressure Plate Motor	Raises and lowers the pressure plate in the master eject box.
37	Master Eject Motor	Sends used masters into the master eject box.
40	Image Shift Motor	Makes a phase difference between the positions of the drum and pressure cylinder for the up/down image shifting mode.
47	Clamper Motor	Opens or closes the drum master clamper.
50	Separation Pressure Motor	Drives the paper separation pressure adjustment mechanism.
58	Main Motor	Drives the drum, pressure cylinder, and paper delivery unit components.
60	Transport Vacuum Fan	Provides suction so that paper is held firmly on the transport belts.
61	Air Knife Fan	Provides air to separate the paper leading edge from the drum.
63	Wing Guide Motor	Changes the position of the paper wing guides in the paper delivery unit.
66	Pressure Cam Shift Motor	Switches the cams for the small master and full size master to apply the appropriate printing pressure.
69	Slider Lift Motor	Moves the sliding arm in the job separator unit up or down.
72	Job Separator Motor	Drives the sliding arm in the job separator unit.
76	Master Feed Control Motor	Controls the master feed control roller operation to feed the master.
78	Cutter Motor	Cuts the master after completing the master making.
82	Platen Release Motor	Applies or releases the pressure between the platen roller and the thermal head.
83	Master Feed Motor	Feeds the master to the drum.
84	Master Vacuum Fan	Provides suction to guide the master into the buffer duct.
87	Ink Pump Motor	Drives the ink pump to supply ink.
89	Idling Roller Motor	Presses or releases the idling roller against the drum screen.
91	Drum Shift Motor	Slides the drum screen position to the front or rear for the side-to-side image shifting mode.
100	Friction Pad Shift Motor	Switches between the normal pad and custom pad (these pads are used for paper separation).

**Sensors**

<b>Index No.</b>	<b>Name</b>	<b>Function</b>
12	Original Width Sensor	Detects the width of the original on the exposure glass.
13	Scanner HP Sensor	Detects when the scanner is at home position.
15	Platen Cover Sensor	Detects if the platen cover is open or closed.
16	Original Length Sensor	Detects the length of the original on the exposure glass.
18	Master Making Unit Set Sensor	Checks if the master making unit is set.
24	Paper Table Lower Limit Sensor	Detects when the paper table is at its lower limit position.
27	Paper Length Sensor	Detects when long paper is on the paper table.
28	Paper Table Set Sensor	Detects if the paper table is closed.
29	Paper End Sensor	Detects if paper is present on the paper table.
30	Paper Height Sensor	Detects if the top of the paper stack on the paper table is at the paper feed height.
31	Paper Registration Sensor	Detects paper approaching the registration roller.
32	Paper Feed Timing Sensor	Detects paper approaching the paper clamber in the pressure cylinder.
38	Pressure Plate HP Sensor	Detects when the pressure plate is at the home position.
39	Pressure Plate Limit Position Sensor	Detects when the pressure plate is at the lowest position.
41	Image Shift HP Sensor	Detects if the pressure cylinder is at the home position. (The up/down image shift is 0.)
42	Image Position Encoder	Sends the image position data to the CPU for display on the operation panel.
43	2nd Drum Position Sensor	Checks the drum position.
44	1st Drum Position Sensor	Checks the drum position.
45	Clamber Close Position Sensor	Detects when the clamber is in the closed position.
46	Clamber Open Position Sensor	Detects when the clamber is in the open position.
48	2nd Drum Master Sensor	Detects if there is a master on the drum, to detect master clamping errors.
49	1st Drum Master Sensor	Detects if there is a master on the drum when the Start key is pressed.
52	Feed Encoder	Detects fluctuations in the pressure cylinder rotation.
53	Feed Start Sensor	Checks the pressure cylinder position for the paper feed start timing.
55	Lower Wrapping Jam Sensor	Detects paper wrapping jams on the pressure cylinder.
58	Master Eject Sensor	Detects master eject misfeeds.
59	Eject Box Set Sensor	Checks if the master eject box is installed.

<b>Index No.</b>	<b>Name</b>	<b>Function</b>
62	Paper Exit Sensor	Detects paper misfeeds at the exit.
64	A3 Cam Sensor	Detects when the A3 printing pressure cam is used.
65	A4 Cam Sensor	Detects when the A4 printing pressure cam is used.
67	Slider Position Sensor	Detects when the job separator slider is fully moved toward the paper on the delivery table.
68	Slider HP Sensor	Detects when the job separator slider is at the home position.
70	Paper Sensor	Detects when the job separator slider touches the paper on the delivery table.
71	Slider Upper Limit Sensor	Detects when the job separator slider is at the uppermost position.
73	Wing Upper Position Sensor	Detects when the paper wing guides are in the upper position.
74	Wing Lower Position Sensor	Detects when the paper wing guides are in the lower position.
75	Master Edge Sensor	Detects the leading edge of the master when a new master roll is installed.
77	Cutter HP Sensor	Detects when the cutter is at the home position.
80	Master Set Sensor	Detects whether a master roll is present.
81	Platen Release Sensor	Detects when the platen pressure is applied against the thermal head.
85	Master End Sensor	Detects when the master runs out.
88	Drum Shift HP Sensor	Detects when the drum screen is at the home position. (The side-to-side image shift is 0.)
90	Drum Shift Sensor	Sends the image position data to the CPU for display on the operation panel.
92	Ink Pump Sensor	Monitors the operation of the ink pump to count how many cycles it has moved.
95	Ink Cartridge Set Sensor	Detects if the ink cartridge is in place.
96	Idling Roller HP Sensor	Detects when the idling roller is at the home position.
98	Friction Pad Position Sensor 1	Checks the position of the friction pad (used for paper separation).
99	Friction Pad Position Sensor 2	Checks the position of the friction pad (used for paper separation).

**Others**

<b>Index No.</b>	<b>Name</b>	<b>Function</b>
14	Xenon Lamp	Applies light to the original for exposure.
20	Interface Connector	Connects the machine to the PC controller.
34	Print and Master Counters	Keeps track of the total number of prints and masters.
79	Thermal Head	Burns the image of the original onto the master.
93	Thermistor	Detects the temperature inside the drum to adjust various process.
94	Ink Detecting Pin	Detects if ink is present in the drum.
98	Drum Home Position Indicator (LEDs)	LEDs that indicates the drum position.





### 1.8.2 MAIN DRIVE

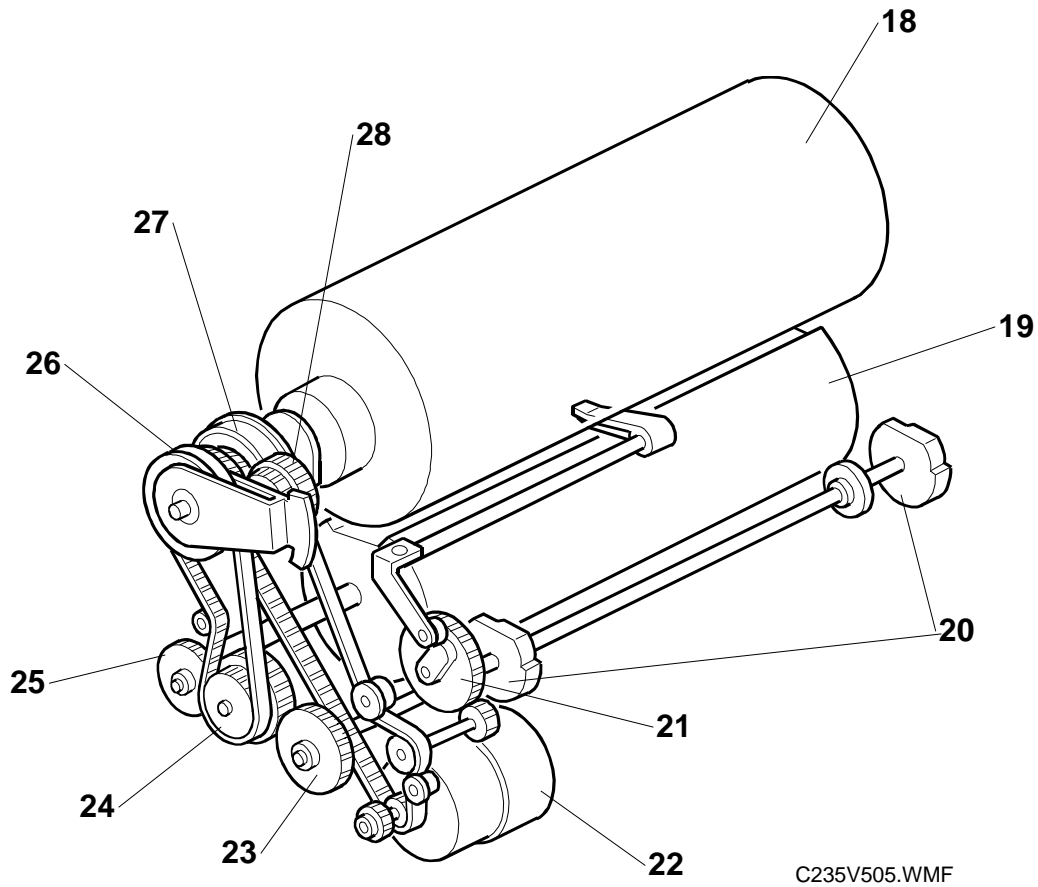

- |                                      |   |
|--------------------------------------|---|
| 18. Drum                             | 24. Idler Gear/Pulley   |
| 19. Pressure Cylinder                | 25. Pressure Cylinder Drive Gear<br>(including the Scissors Gear) |
| 20. Printing Pressure Cam            | 26. Primary Gear/Pulley   |
| 21. Exit Pawl Drive Cam Gear         | 27. Drum Drive Gear/Pulley  |
| 22. Main Motor                       | 28. Image Shift Gear  |
| 23. Printing Pressure Cam Drive Gear |   |

## 2. DETAILED SECTION DESCRIPTIONS

### 2.1 SCANNER AND OPTICS

#### 2.1.1 OVERVIEW

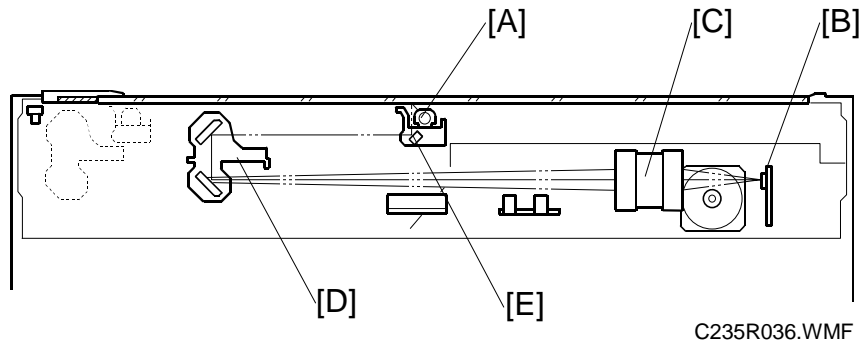

Detailed  
Descriptions

The original is illuminated by the exposure lamp (a xenon lamp in this model) [A]. The image is reflected onto a CCD (charge coupled device) [B] via the 1st, 2nd, 3rd mirrors, and lens [C].

The 1st scanner [D] consists of the exposure lamp, and the 1st mirror [E].

A lamp stabilizer energizes the exposure lamp. The light reflected by the reflector is of almost equal intensity, to reduce shadows on pasted originals.

#### 2.1.2 SCANNER DRIVE

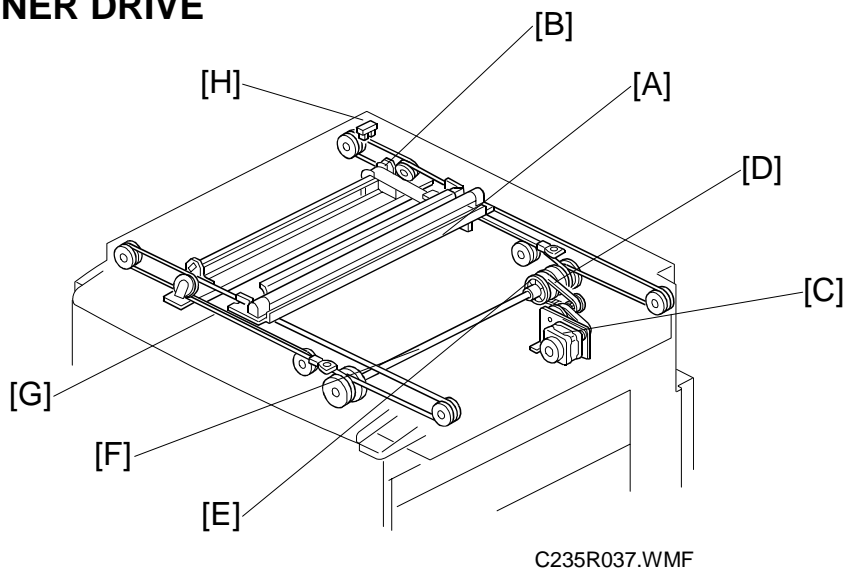

A stepper motor drives the scanner. The 1st and 2nd scanners [A, B] are driven by the scanner drive motor [C] through the timing belt [D], scanner drive pulley [E], scanner drive shaft [F], and two scanner wires [G].

**- Book mode -**

The scanner drive board controls and operates the scanner drive motor. In full size mode, the 1st scanner speed is 42.33 mm/s during scanning. The 2nd scanner speed is half that of the 1st scanner.

In reduction or enlargement mode, the scanning speed depends on the magnification ratio (M: 0.50 to 2.00). The returning speed is always the same, in both full size and magnification modes. Changing the scanner drive motor speed changes the image length in the sub-scan direction. Image processing on the MPU board accomplishes reduction and enlargement in the main scan direction.

SP6-001-5 changes the motor speed and therefore adjusts the magnification ratio in the sub-scan direction.

**- ADF mode -**

During scanning, the scanners are always in their home positions (when the scanner H.P sensor [H] detects the 1st scanner). The DF transport motor feeds the original through the ADF. In reduction/enlargement mode, changing the motor speed changes the image length in the sub-scan direction. Magnification in the main scan direction is done on the MPU board, in the same manner as book mode.

SP6-001-6 changes the DF transport motor speed and therefore adjusts the magnification ratio in the sub-scan direction.

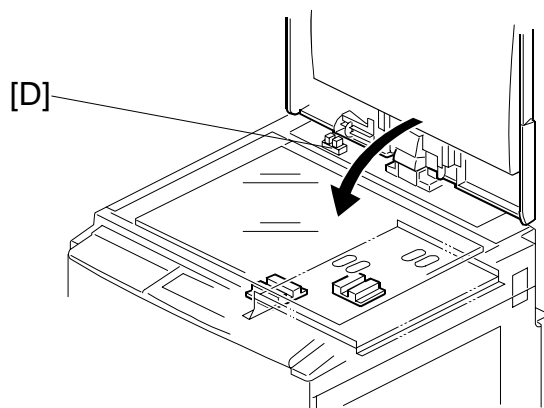
**2.1.3 ORIGINAL SIZE DETECTION IN PLATEN MODE**

C235R038.WMF

In the optics cavity for original size detection, there are four reflective sensors in the 115V machines ([A] and [B]), and six reflective sensors in the 230V machines. The original width sensors [A] detect the original width, and the original length sensors [B] and [C] detect the original length. These are the APS (Auto Paper Select) sensors. Each APS sensor is a reflective photosensor.

While the main switch is on, these sensors are active and the original size data is always sent to the CPU. However, the CPU checks the data only when the platen cover sensor [D] is activated. This is when the platen is positioned about 15 cm above the exposure glass, for example while it is being closed. The CPU can recognize the original size from the combination of on/off signals from the APS sensors.

If the copy is made with the platen fully open, the CPU decides the original size from the sensor outputs when the Start key is pressed.

Detailed Descriptions

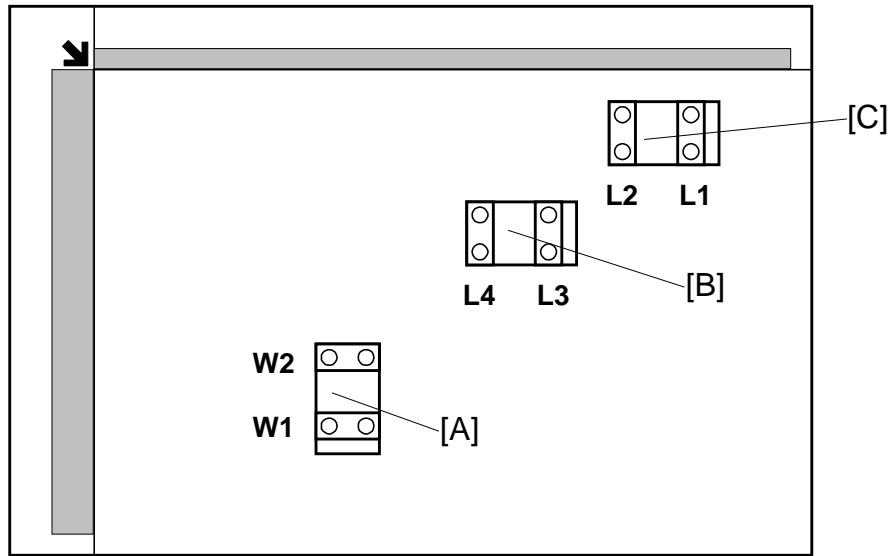

C235D805.WMF

Original Size		Length Sensor				Width Sensor	
A4/A3 version	LT/DLT version	L4	L3	L2	L1	W2	W1
A3	11" x 17"	O	O	O	O	O	O
B4	10" x 14"	O	O	O	O	O	X
Foolscap	8.5" x 13"	O	O	O	X	X	X
A4-L	8.5" x 11"	O	O	X	X	X	X
B5-L		O	X	X	X	X	X
A4-S	11" x 8.5"	X	X	X	X	O	O
B5-S		X	X	X	X	O	X
A5-L, A5-S		X	X	X	X	X	X

**NOTE:** 1) L: Lengthwise, S: Sideways, O: High (paper present), X: Low  
 2) The length sensors L3 and L4 are used only for 115V machines.

The above table shows the sensor output for each original size. A message will appear in the operation panel display for other combinations.

## 2.2 IMAGE PROCESSING

### 2.2.1 OVERVIEW

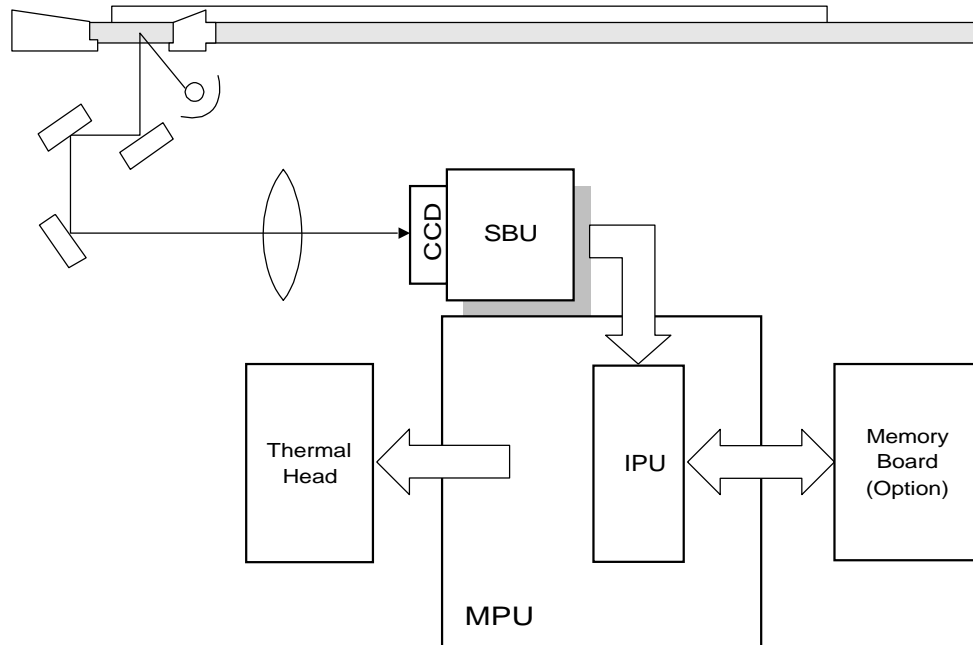

C235D601.WMF

The CCD converts the light reflected from the original into an analog signal. The CCD line has 7,450 pixels and the resolution is 600 dpi (23.6 lines/mm).

After the above process, the A/D converter built into the SBU transforms the analog signals into 8-bit signals. This assigns a value to each pixel from a scale of 256 grades. Then, the digitized image data goes to the MPU board.

The image data then goes to the IPU (Image-processing Unit) IC on the MPU board, which carries out the following processes on the image data:

- 1) Auto shading
- 2) Filtering (MTF and smoothing)
- 3) Magnification
- 4) Binary processing

## 2.2.2 AUTO BACKGROUND CORRECTION

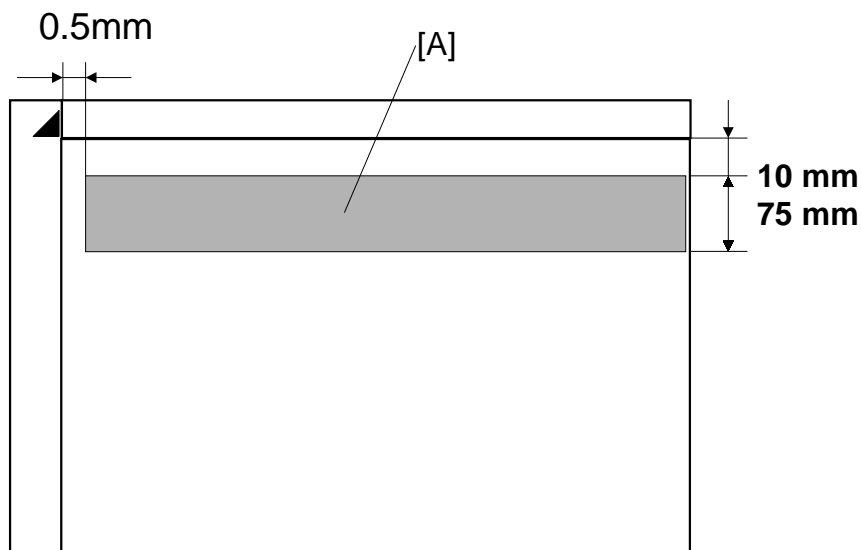

Detailed  
Descriptions

C235D802.WMF

Auto background correction mode can be used in Photo/Letter, Photo, and Tint modes. The default setting does not allow the user to select auto background correction mode. (Use the user tools 4-6 to enable this mode.)

Auto background correction prevents the background of an original from appearing on copies.

While scanning the original, the background density detection area [A] is also scanned. This area [A] is a narrow strip at the start of the main scan line, as shown. As the scanner scans down the page, the IPU on the MPU detects the peak white level for each scan line, within this narrow strip only. From this peak white level, the IPU determines the reference value for the A/D conversion for the scan line. The IPU then sends the reference value to the reference controller on the SBU.

When an original with a gray background is scanned, the density of the gray area is the peak white level density. Therefore, the original background will not appear on copies. This feature corrects any changes in background density down the page, because peak level data is taken for each line scanned.

### **2.2.3 AUTO SHADING**

There are two auto shading methods. black level correction and white level correction. Auto shading corrects errors in the signal level for each pixel.

#### ***Black Level Correction***

The CPU reads the black dummy data from one end of the CCD signal (32 pixels at the end are blacked off) and takes the average of the black dummy data. Then, the IPU deletes the black level value from each image pixel.

#### ***White Level Correction***

Before scanning the original, the machine reads a reference waveform from the white plate. The average of the white video level for each pixel is stored as the white shading data in the FIFO memory in the IPU chip.

The video signal information for each pixel obtained during image scanning is corrected by the IPU chip.

Auto shading for the first original is done before the scanning.

After scanning every page, auto shading is done to prepare for the next page.

If the copy image density or the original mode is changed during copy run, the auto shading for the next scan is done before the scanning to respond to the mode changed.



## 2.2.4 FILTERING AND MAIN SCAN MAGNIFICATION/REDUCTION

### Overview

Filtering and main scan magnification process the image data after auto shading. However, to reduce moire in the image, the processing order depends on the reproduction ratio, as follows:

- 1) Reduction and Full size  
Main Scan Reduction → Filtering
- 2) Enlargement  
Filtering → Main Scan Magnification

### Filtering

The MTF software filters enhance the desired image qualities of the selected original mode.

The MTF filter is used in all modes (Letter, Letter/Photo, Photo, Pencil, Thin). SP6-006 adjusts the filter strengths for MTF mode.

Using SP mode, the filter strengths can be set respectively in the main scan direction and the sub-scan direction.

When the filter is stronger in the main scan direction, lines parallel to the feed direction are emphasized.

When the filter is stronger in the sub-scan direction, lines at right angles to the feed direction are emphasized.

Filter Number	MTF Filter Strength
7	x 4
6	x 2
0	x 1
5	x 1/2
4	x 1/4
3	x 1/8
2	x 1/16
1	x 1/32

**Main Scan Magnification/Reduction**

Changing the scanner speed enables reduction and enlargement in the sub-scan direction. However, the IPU chip handles reduction and enlargement in the main scan direction. The processing for main scan magnification/reduction is the same as in the previous digital machines.

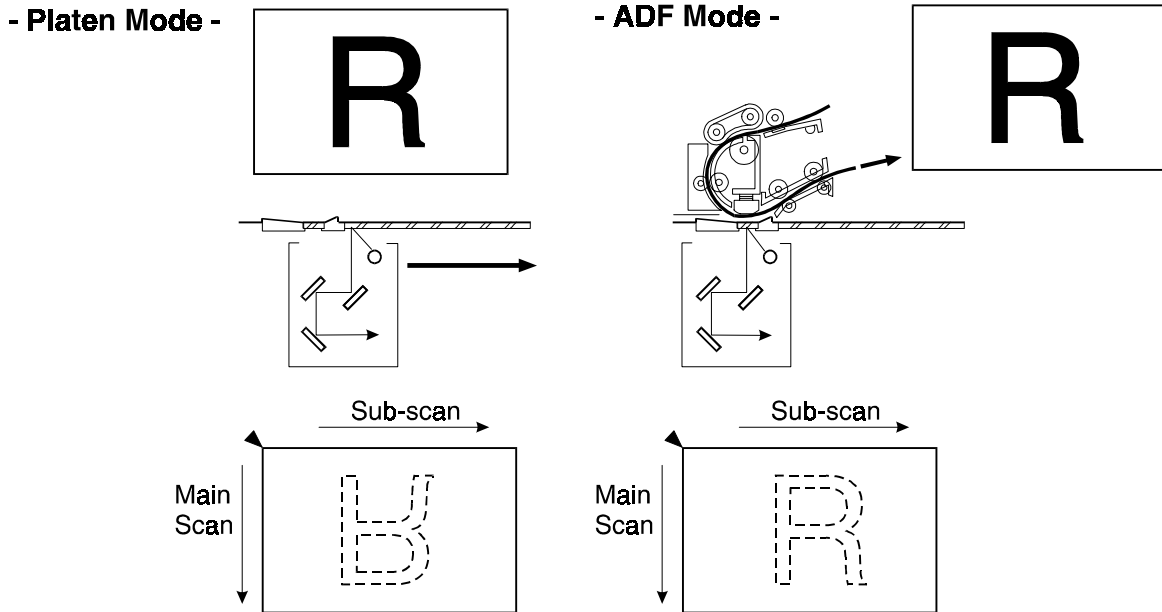

C235D804.WMF

**2.2.5 BINARY PROCESSING**

In the IPU chip, the 8-bit data is converted into 1-bit data for black or white pixels. The binary processing for the letter mode is different from that for the photo mode and the letter/photo mode as follows:

- 1) Letter mode: Binary processing
- 2) Letter/Photo mode: Binary processing
- 3) Photo mode: Binary processing + error diffusion + dithering

These processes are used as follows.

**- Binary Processing with Gamma Curve Compensation -**

This process converts each video signal level from 8-bit to 1-bit (black and white image data) in accordance with a threshold value.

The threshold value changes based on a compensation curve (Gamma curve) which corresponds to selected image settings. For example, if a darker image is selected, a compensation curve, which converts each pixel value to a higher number, is selected. This ensures accurate generation of the gray scale from black to white.

#### **- Error Diffusion - (Photo mode only)**

The error diffusion process reduces the difference in contrast between light and dark areas of a halftone image. This process corrects each pixel using the difference between it and surrounding pixels. It then compares the corrected pixels with the error diffusion matrix.

#### **- Dithering - (Photo mode only)**

Dithering compares each pixel with a pixel in the dither matrix. Several matrixes are available, to increase or decrease the detail on the copy.

### **2.2.6 MEMORY BOARD**

The memory board, or editing function board, has 4-Mbyte RAM, which corresponds to the amount of memory required for an A3 original. This enables the following image editing functions.

#### **- Memory Combine Mode -**

Combined images of 4, 8, or 16 originals are printed on the same sheet of paper.

#### **- Overlay -**

Overlay merges two different originals onto the same sheet of paper.

#### **- Stamp Printing Mode -**

This mode enables stamping modes such as, the date, page number, preset message, and user custom stamps.

**- Make-up Printing Mode -**

The user makes command sheets to specify how various areas of the original will be processed. The user must be sure to scan the command sheets before the original. The image-processing chip in the MPU modulates the image data for the command sheet and then stores the modulated command data on the memory board.

The image data for the original is also converted and modulated. The MPU edits the modulated image data, the stored command area data, and the background pattern.

Positive/Negative can be used with this mode.

**- Report Print Mode -**

This mode prints the following data:

- User reports
- Jam and error counter data
- The number of people in each class set by the user
- Number of prints and masters for each user code account
- SP mode data for service

**- Image Rotation Mode -**

When the orientation for the original differs from the paper selected, the machine automatically rotates the original image 90 degrees to match the paper orientation.

User Tools 4-20 can disable this mode.

**2.2.7 THERMAL HEAD*****Specifications***

- |                                    |               |
|------------------------------------|---------------|
| • Length                           | 303.42±0.1 mm |
| • Number of thermal head elements  | 7168          |
| • Density of thermal head elements | 600 dpi       |

***Thermal Head Control***

The thermal head contains heating elements at a density of 600 dpi. The thermal heating elements melt the over-coating and polyester film layers of the master, in accordance with the image signal for each pixel.

The function of the thermal head power supply board is included in the PSU. The PSU applies power (VHD) to the thermal heating elements. The power source varies from one head to another since the average resistance of each element varies. Therefore, when replacing the thermal head or power supply unit, it is necessary to readjust the applied voltage to the specific value for the thermal head.

***Thermal Head Protection***

The thermistor on the thermal head provides thermal head protection, preventing the thermal head from overheating when processing a solid image. The CPU checks for any abnormal condition when the Start key is pressed; it displays an SC code on the operation panel as follows:

<b>SC Code</b>	<b>Conditions</b>	<b>Detecting Component</b>
SC03-03	Over 54°C	Thermistor
SC03-02	Under - 20°C (Normally in this case, the thermistor is open, or a related connector is disconnected.)	Thermistor
SC03-01	When the pulse width that controls the thermal head energy becomes abnormal, master making stops and generates this SC code.	MPU
SC03-00	The CPU monitors the ID signal from the thermal head, which identifies the thermal head type. If an abnormal ID signal is detected just after installing the master making unit in the machine, it generates this SC code.	MPU

**Remarks for Handling the Thermal Head**

Pay careful attention to the following remarks when servicing:

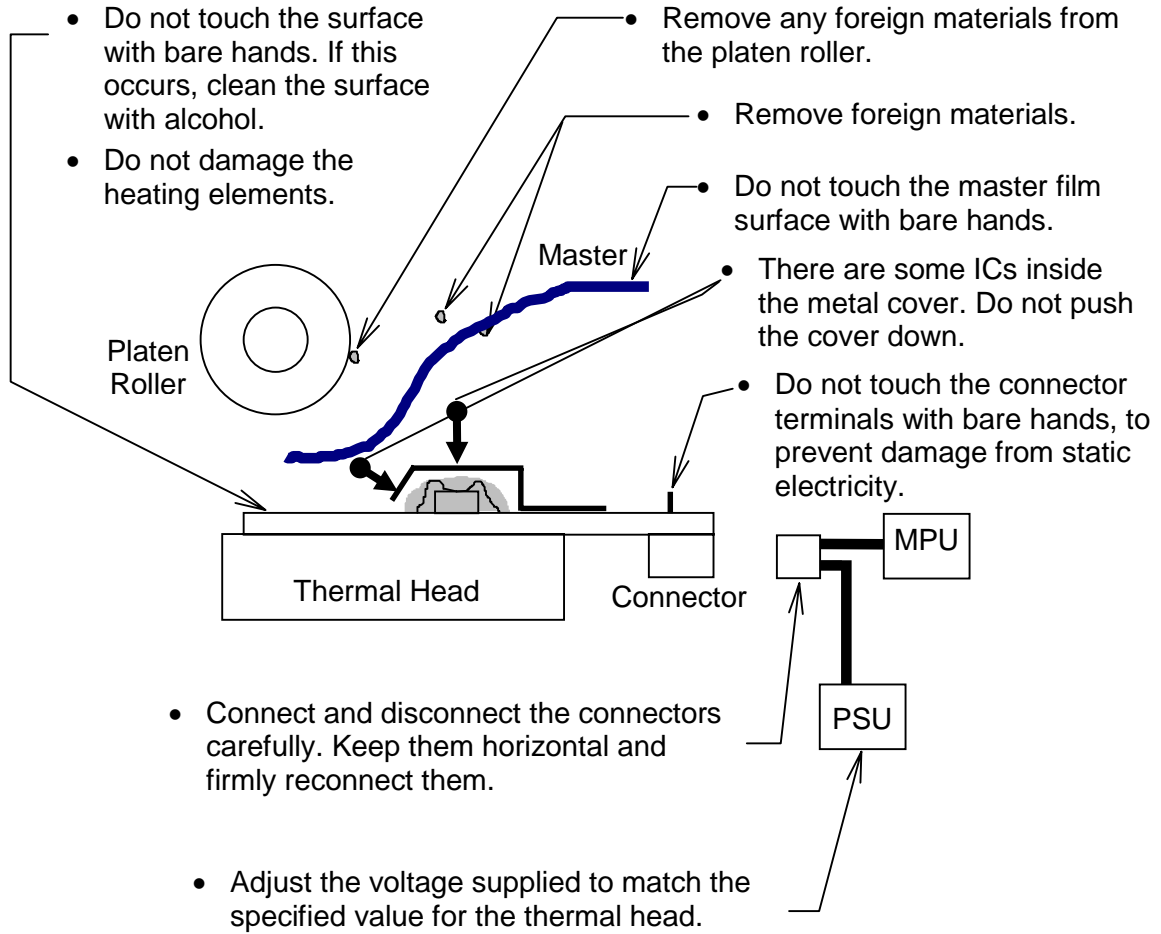

**- Other Remarks -**

Avoid using the machine under humid conditions. Moisture tends to condense on the thermal head, damaging the elements.

## 2.3 MASTER EJECT

### 2.3.1 OVERVIEW

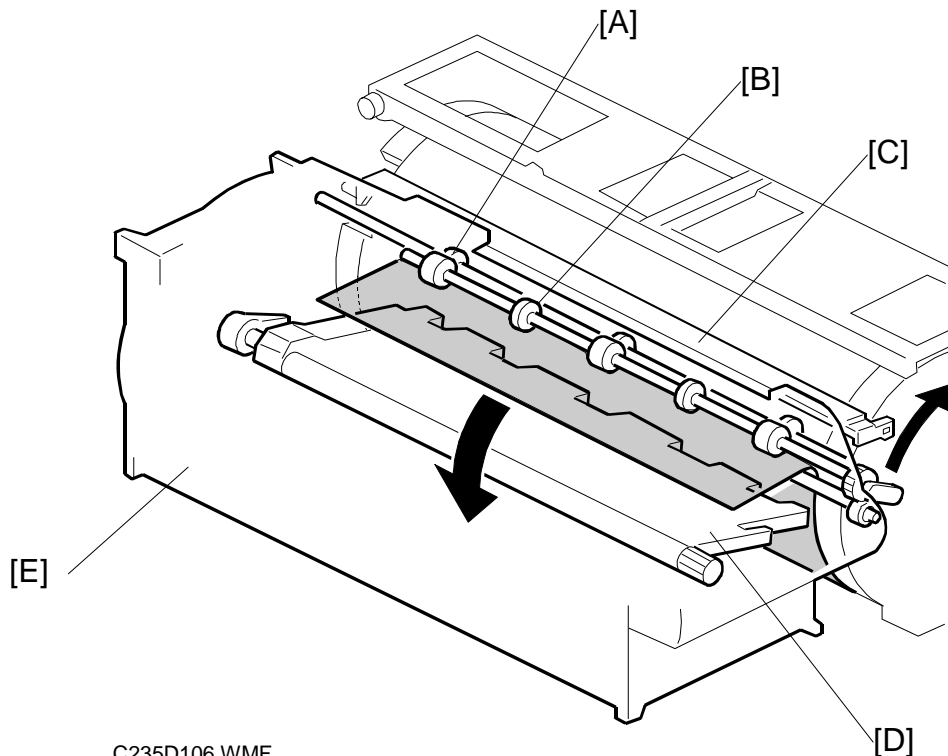

C235D106.WMF

Detailed  
Descriptions

The master remains wrapped around the drum to prevent the ink from drying. Therefore, making a new master begins from the master ejecting process.

When the Start key is pressed to scan the original, the drum rotates from the home position to the master eject position. As soon as the drum reaches the master eject position, the drum master clamber [C] opens. The drum position lock mechanism locks the drum at this position to prevent the drum from moving during master ejection.

At the same time, the master pick-up roller [A] touches the drum, picking up the leading edge of the master on the drum. Then, the master is caught by the upper and lower master eject rollers [B] and is transported into the master eject box [E].

When the trailing edge of the master passes the roller, the pressure plate [D] begins to compress the master into the box.

Before this process is complete, the original scanning and master making has already started, and the drum will then rotate to the master making position.

## 2.3.2 MASTER EJECT MECHANISM

### Overview

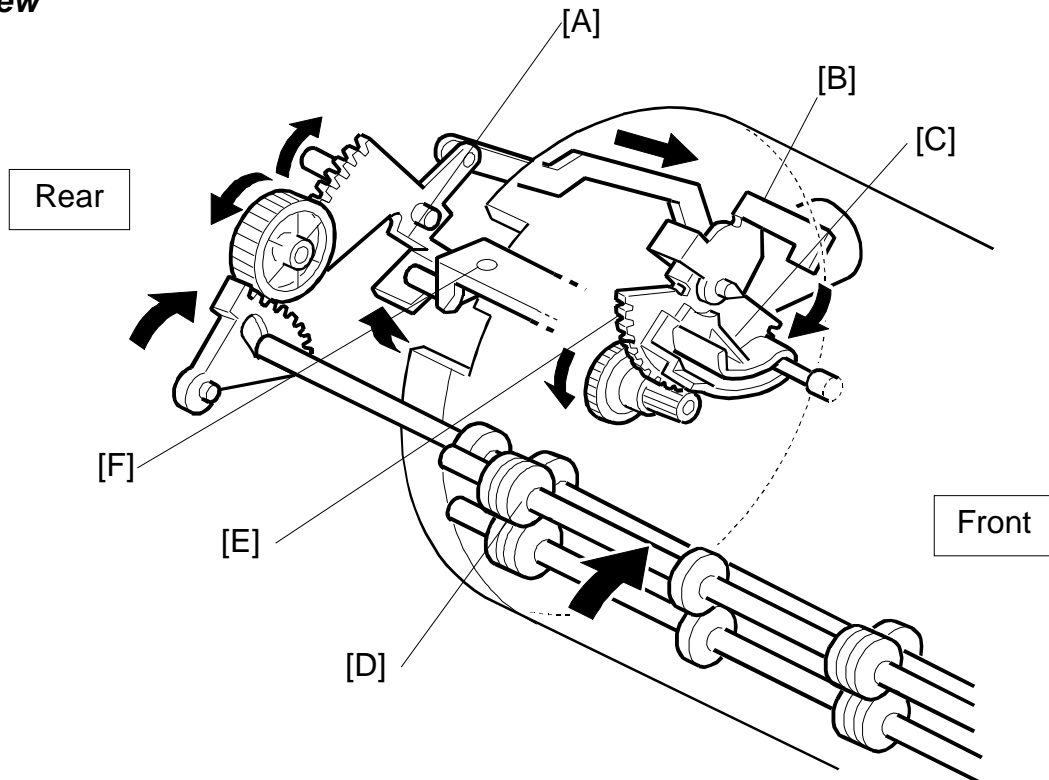

C235D112.WMF

Two photosensors (the 1st and 2nd drum position sensors) and the feeler on the rear drum flange determine the drum position. The drum is at the home position when the feeler actuates the 1st drum position sensor. At this position, the drum master clamber, which clamps the leading edge of the master onto the drum, is located at the bottom of the drum. (For details, refer to Drum Drive Mechanism in the Drum section.)

The drum turns 114.5 degrees from the home position to reach the master eject position (there is no sensor for master eject position detection – main motor encoder pulses only). As soon as the drum stops, the clamber motor [B] starts to open the drum master clamber [F]. The master pick-up roller [D] moves against the drum at the same time, because it is connected through an idle gear.

A link plate connects the drum guide [E] to the clamber opening arm [A]. So, when the arm moves, the drum guide also moves, and this locks the drum position.

- NOTE:**
- 1) To lock the drum, the drum guide catches one of two studs at different positions on the drum. The drum guide catches one stud at the master eject position [C], and the other stud at the master making position.
  - 2) The drum master clamber also opens when the drum is at the master making position. However, it uses a different clamber-opening arm. For details, refer to the Master Making section.
  - 3) Do not clean the inside of the master clamber with alcohol or other strong solvents. Use a cloth dampened with water. This prevents the magnetic force from weakening. This part requires periodic cleaning.



### ***Drum Lock Mechanism***

The clamper motor drives the drum guide [C]. The clamper closed position sensor [A] and clamper open position sensor [B] monitor the position of the drum guide.

When the drum reaches the master eject position, the drum guide moves until the clamper open position sensor [B] is actuated then deactuated (the actuator must go through the sensor). This engages the stud on the rear drum flange.

Before the drum starts rotating to the master making position, the drum guide returns to the home position. The clamper closed position sensor [A] determines this position.

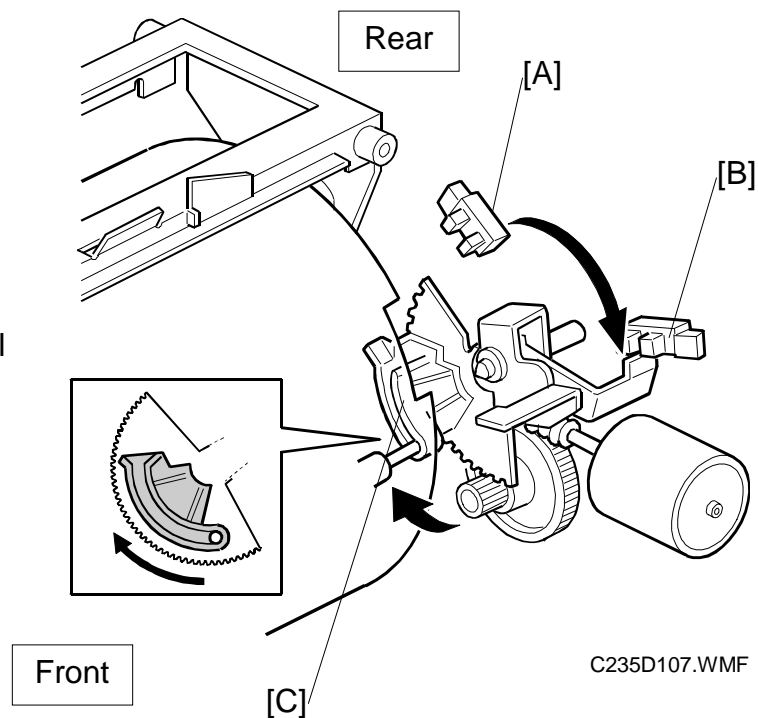

Detailed  
Descriptions

**NOTE:** The same drum guide also moves when the drum is at the master making position. (There is another stud on the rear drum flange, which is used to secure the drum at the master making position.)

A link plate at the master eject position synchronizes the master clamper with the drum guide movement.

To open the clamper, the drum guide (with the clamper opening arm) must move a greater distance than at the master making position. Therefore, at the master eject position, the drum guide moves (to open the master clamper) until the clamper open position sensor [B] turns on (interrupted by the feeler) and then turns off again, as shown in the diagram. Refer to the Master Feed section to compare the two mechanisms.

**Master Pick-up Roller Drive and Master Clamper Open**

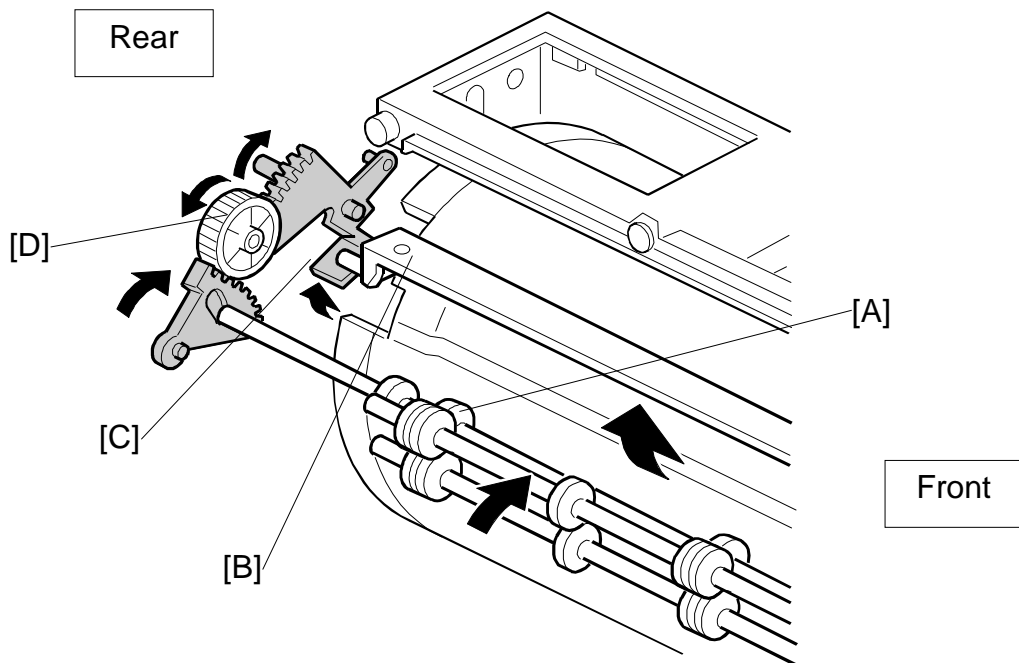

C235D081.WMF

When the clasper motor opens the drum master clasper [B], the master pick-up roller [A] contacts the leading edge of the master on the drum. The clasper motor moves the master pick-up roller against the drum through the idle gear [D], while driving the clasper opening arm [C].

At the same time as the drum master clasper [B] closes after the master is picked up, the master pick-up roller [A] also moves back to the original position.

The drum guide is also released at the same time. The drum continues turning towards the master making position while the used master is removed from the drum.

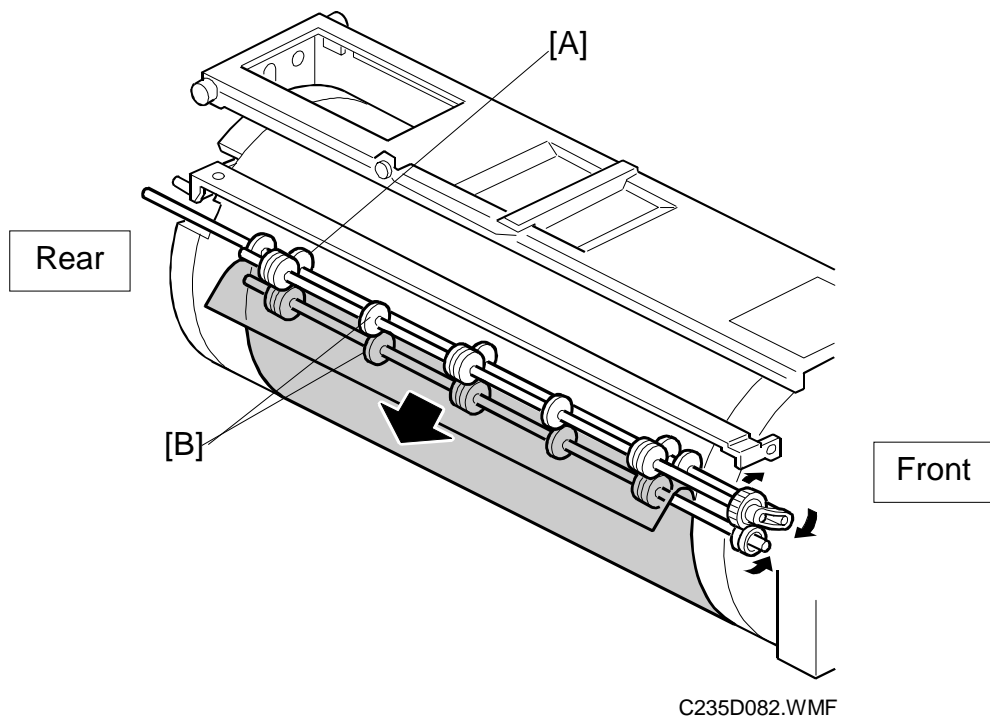
**Master Eject and Transportation**Detailed  
Descriptions

The master pick-up roller [A] and the upper and lower master eject rollers [B] all turn together. They start turning as soon as the drum reaches the master eject position.

The rollers stop once the leading area of the master is picked up from the drum. (The master eject sensor detects this.) Then, when the drum starts turning, they turn on again to feed the ejected master to the eject box while the drum turns towards the master making position.

The master eject sensor (not shown) is located just under the lower master eject roller, and it monitors the master feeding. If the master is not properly picked up, i.e. it does not activate the sensor; the operation panel displays a master eject jam message.

**Master Eject Roller Unit Drive**

The master eject motor [A] turns the master pick-up roller [B] with the upper and lower master eject rollers [C].

When the unit is slid out (explained below), the joint [D] disengages.

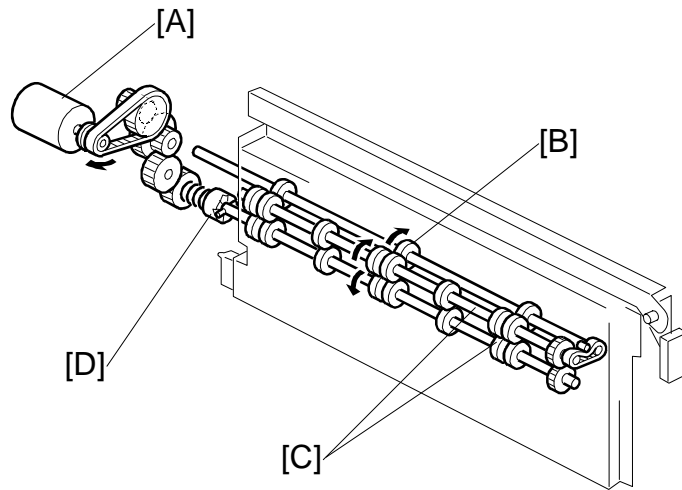

C235d513.WMF

**Master Eject Roller Unit Slide-out Mechanism**

The master eject roller unit [E] can be slid out of the machine as shown for easy master jam removal.

The unit contains the master pick-up roller, upper and lower master eject rollers, and the master eject sensor.

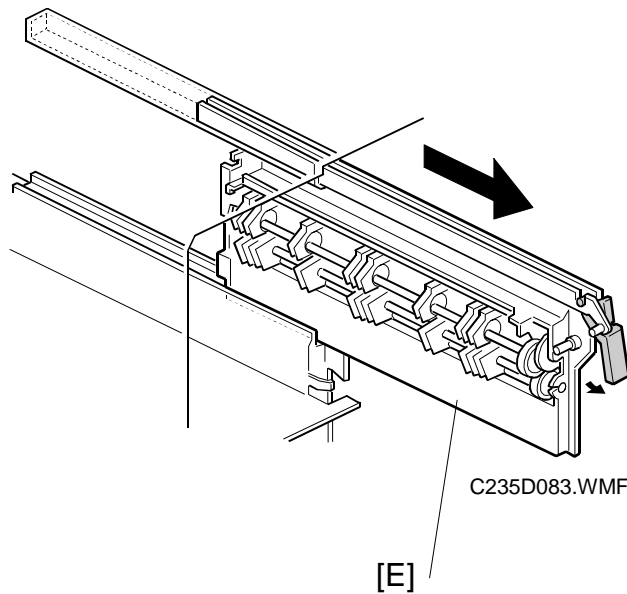

C235D083.WMF

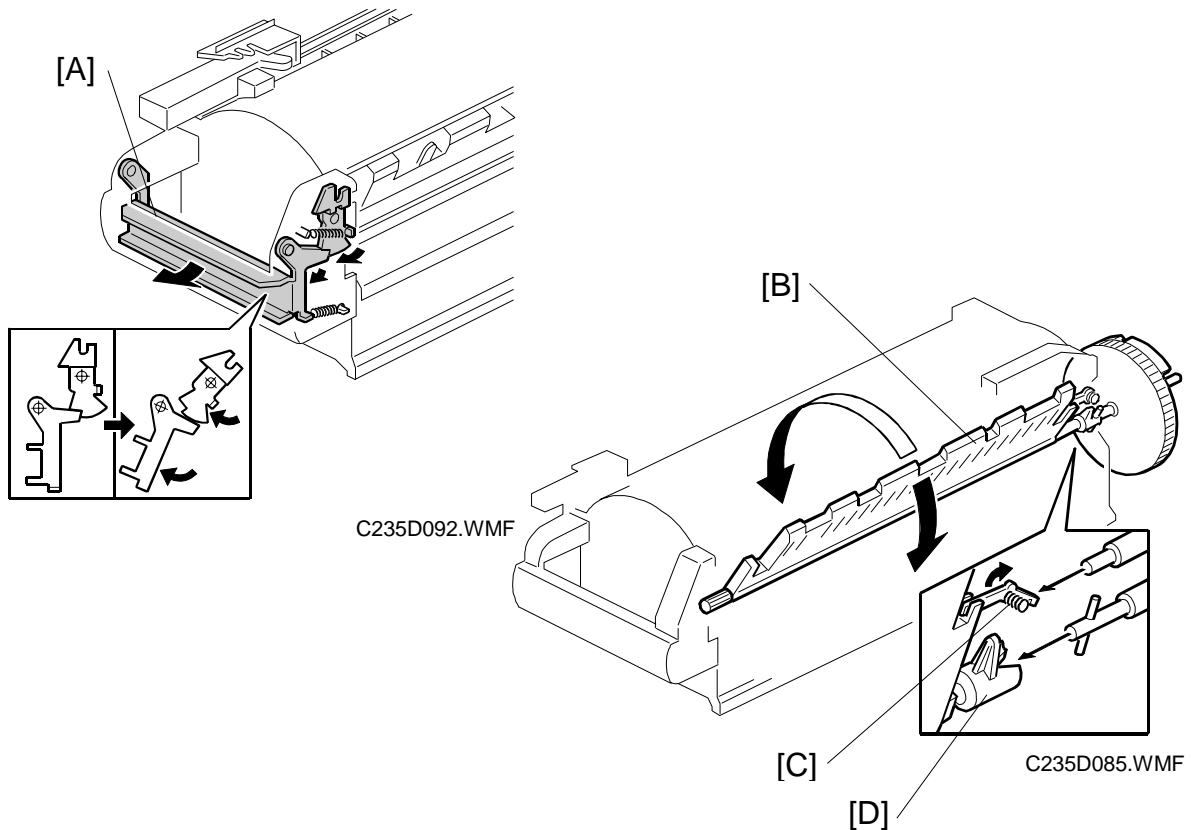
**Master Eject Box Mechanism**

The user can slide the master eject box out from the operation side of the machine. The front handle of the box [A] has a lock mechanism as shown above.

The master eject box contains a pressure plate [B], which compresses the ejected masters in the box. The pressure plate also works as a guide plate feeding the ejected master into the box.

An independent dc motor, the pressure plate motor, drives the pressure plate. The motor is in the pressure plate drive unit, on the rear frame of the machine separate from the master eject box.

When the master eject box is slid out, the joint [D] for the pressure plate drive disengages. At the same time, the lock lever [C] turns, due to tension from a spring, to hold the pressure plate [B] in the home position.

When the master eject box is re-installed, the drive joint [D] is connected and the pressure plate lock lever [C] is released as shown above.

The ejected masters in the box can be taken out by sliding the eject lever [A]. The inner bottom case [C] moves towards the rear of the box.

Masters are ejected from an open door at the rear of the box. The side opposite the eject lever side [A] of the inner bottom case is connected to a belt [B]. This helps the inner bottom case move smoothly.

When the master eject box is removed, a push switch (the eject box set sensor) turns off, and the operation panel displays a message.

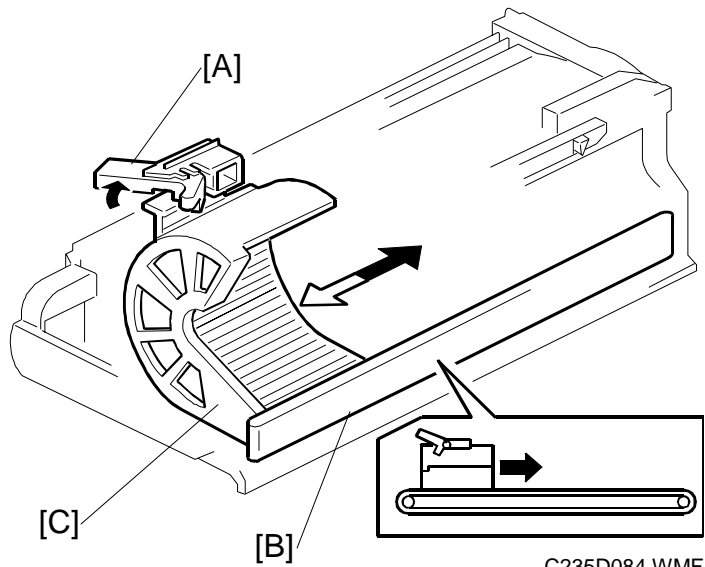

### 2.3.3 PRESSURE PLATE DRIVE MECHANISM

#### Overview

There are three phases.

- Homing  
At power on or when recovering from an error or jam, the machine makes sure that the pressure plate is at home position. This is because, if certain errors occur, the pressure plate may not be in the home position at the start of a job
- Master ejection  
The pressure plate rotated into a position where it can act as a feed guide for the used master on its way to the eject box.
- Compression  
The pressure plate compresses the master into the box.

Detailed  
Descriptions

#### Drive

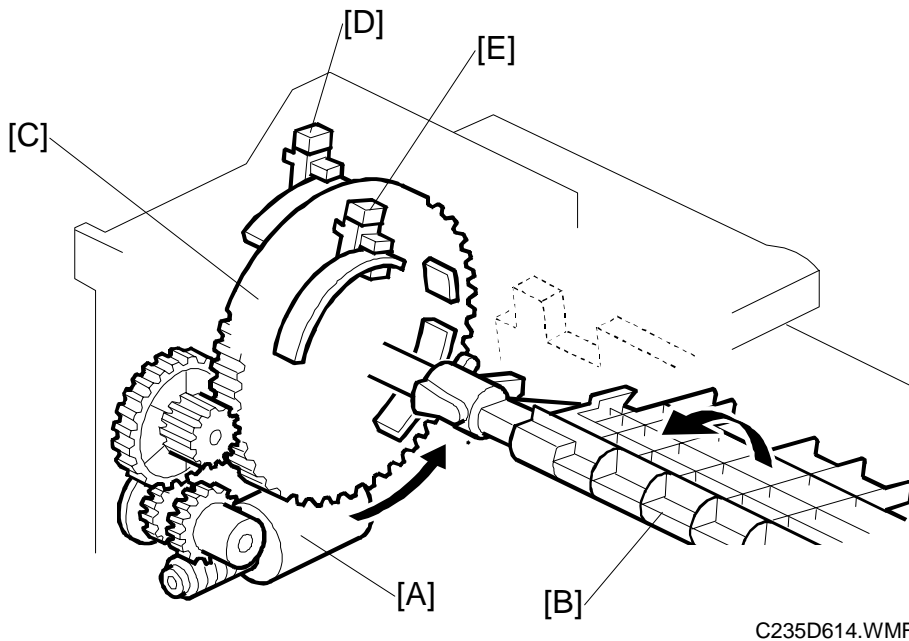

The pressure plate motor [A] drives the pressure plate [B] through the pressure plate gear [C]. This gear contains actuators for the home position sensor [D] and the limit position sensor [E]. These two sensors monitor the pressure plate position.

The diagram shows a front view of the mechanism. The actuators are on the rear of the pressure plate gear, which is shown as see-through for ease of viewing.

**Homing Operation**

At power on or when recovering from an error or jam condition, the machine carries out the pressure plate homing operation.

If certain errors occur, the pressure plate may not be in the home position. The homing operation starts by turning the pressure plate toward the drum and then it returns to the home position.

The homing operation is as follows:

1. The pressure plate turns clockwise (as seen from the operation side) until both the pressure plate HP sensor [A] and the limit position sensor [B] are actuated.
2. As shown in the upper right diagram, the pressure plate turns counterclockwise until the home position sensor [A] is actuated twice then de-activated. The status of the sensor [A] changes: on ⇒ off ⇒ on ⇒ off.
3. The pressure plate has just slightly passed the home position. Then, as shown in the lower right diagram, the pressure plate again turns clockwise to return to the exact home position. The home position sensor status changes now from: off ⇒ on ⇒ off.

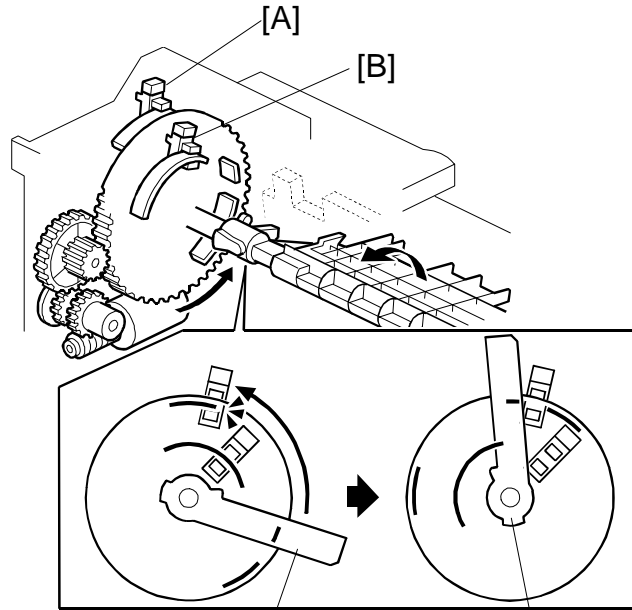

C235D089.WMF

Master Eject Ready Position

Passed the home position slightly

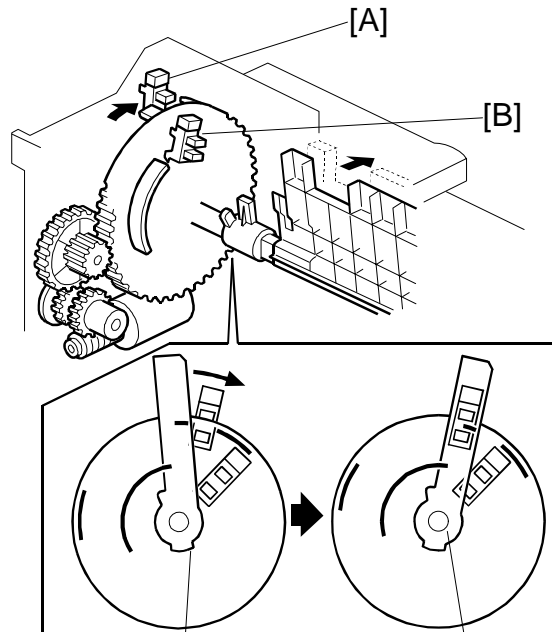

C235D114.WMF

Passed the home position slightly

Home Position



### ***Shift to the Master Eject Position***

When the Start key is pressed to make a new master, the drum turns to the master eject position. During this period, the pressure plate travels to the master eject ready position.

The pressure plate turns clockwise (as seen from the operation side) until both the pressure plate HP sensor [A] and the limit position sensor [B] are actuated.

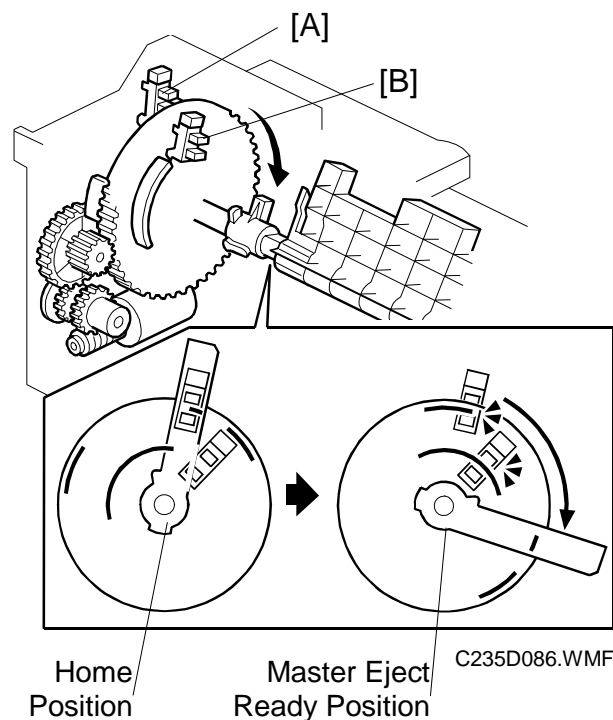

Detailed  
Descriptions

### ***Ejected Master Compression***

When the ejected master has been fed to the master eject box, the pressure plate compresses the master. During this operation, the machine can recognize how full the eject box is by monitoring the lower limit and home position sensors.

#### ***When there are no or very few masters in the box***

If there are no or only a few masters in the box, the pressure plate can move to its lowest position. The pressure plate limit position sensor detects this position.

The pressure plate turns counterclockwise from the master eject ready position until the limit position sensor [B] has been actuated twice. The sensor status changes: on  $\Rightarrow$  off  $\Rightarrow$  on.

The pressure plate stays at the lower limit position for 2 seconds, then returns to the home position.

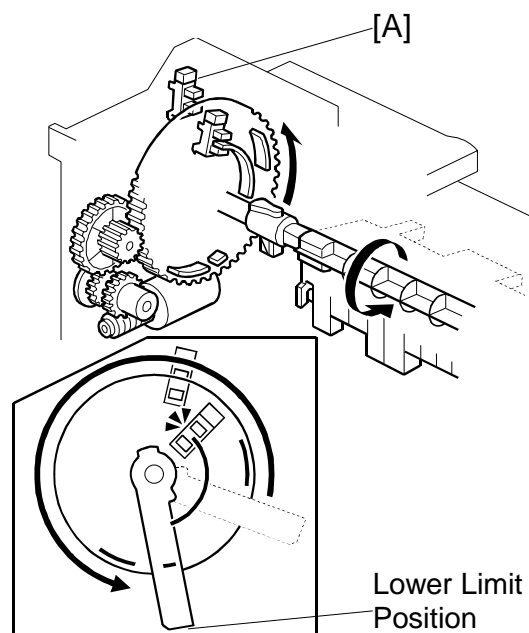

Lower Limit  
Position

C235D087.WMF

***When there are a lot of masters***

If there are a lot of used masters in the box, the pressure plate cannot move to the lower limit position.

If the lower limit position sensor [B] is not actuated within 7 seconds after the pressure plate starts traveling from the master eject ready position, the pressure plate motor stops.

The pressure plate stays in the same position for 2 seconds to compress the masters. Then, it returns to the home position.

There is a torque limiter [C] built into the gear. When the built-up masters in the box block pressure plate movement, the torque limiter allows this gear to slip.

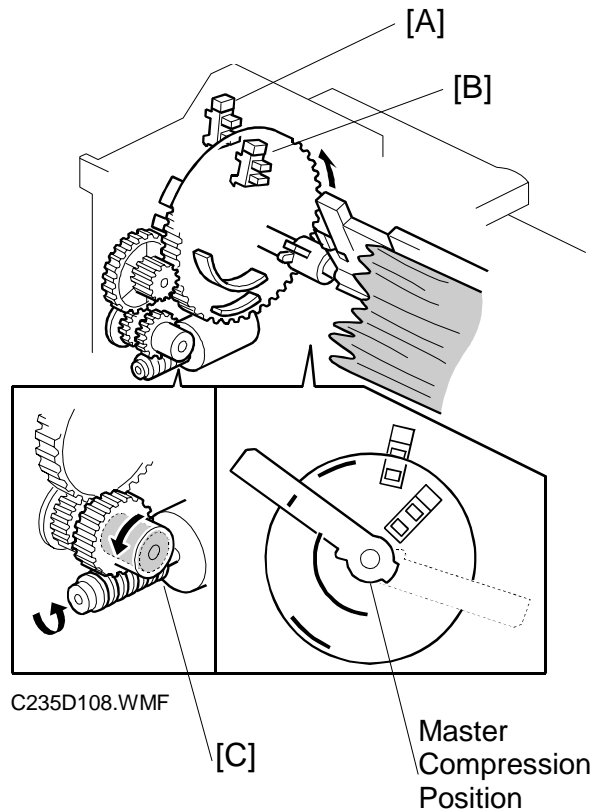

***Master Box Full Detection Mechanism***

As explained above, the pressure plate motion range narrows as the ejected masters build up in the box. The stopping position of the pressure plate therefore gets closer to the home position.

When the pressure plate cannot travel past the master box full position from the master eject ready position, this means that the master box is full.

In this case, the home position sensor [A] remains actuated as shown on the right.

The home position sensor status changes (from the master eject ready position): on ⇒ off ⇒ on ⇒ off ⇒ on, and stays on. This means the master box is full and the operation panel displays a message.

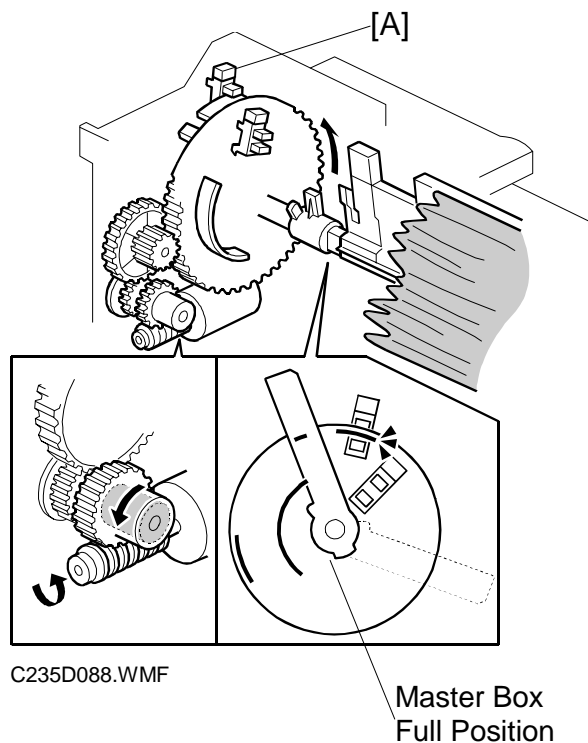

**Pressure Plate Operation Timing Chart**

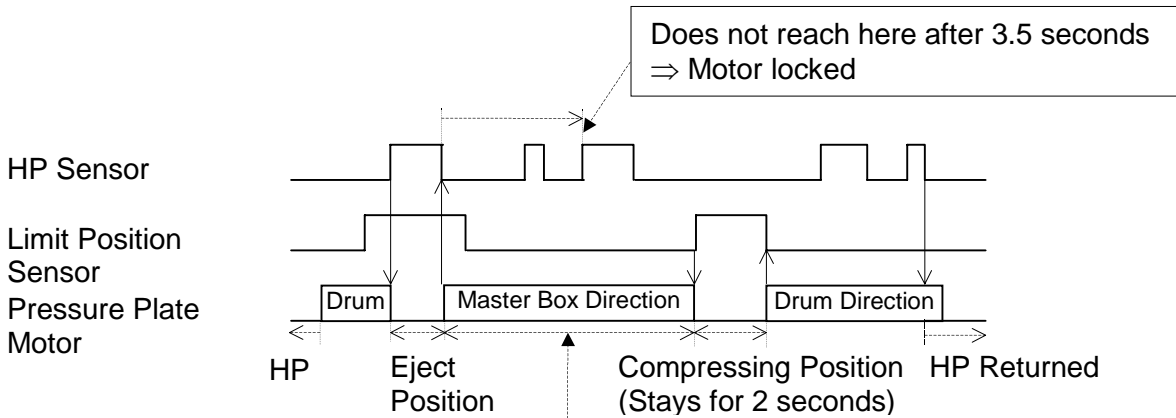

Detailed Descriptions

<p>Check when rotating in the master box direction →</p> <p>- Check Timing - When one of the following occurs:</p> <ol style="list-style-type: none"> <li>1. When the Limit Position Sensor turns on.</li> <li>2. 3.5 seconds after the motor turns on.</li> </ol>	<p><u>Number of HP Sensor On or Off Edges</u> (The first 'on' edge is just after the motor starts.)</p> <ul style="list-style-type: none"> <li>• 5 times ⇒ Normal</li> <li>• 4 times ⇒ Master box full</li> <li>• Less than 4 ⇒ Pressure plate locked (SC06-00 lights)</li> </ul>
--	---

This timing chart shows how the machine counts the number of home position sensor on and off edges to check if the eject box is full or if the mechanism is jammed.

The signal is checked when:

- The limit position sensor turns on – this is when the pressure plate has turned all the way to the lower limit position inside the box, which is only possible if the box is fairly empty.
- At 3.5 s after the motor turns on

## 2.4 MASTER FEED

### 2.4.1 OVERVIEW

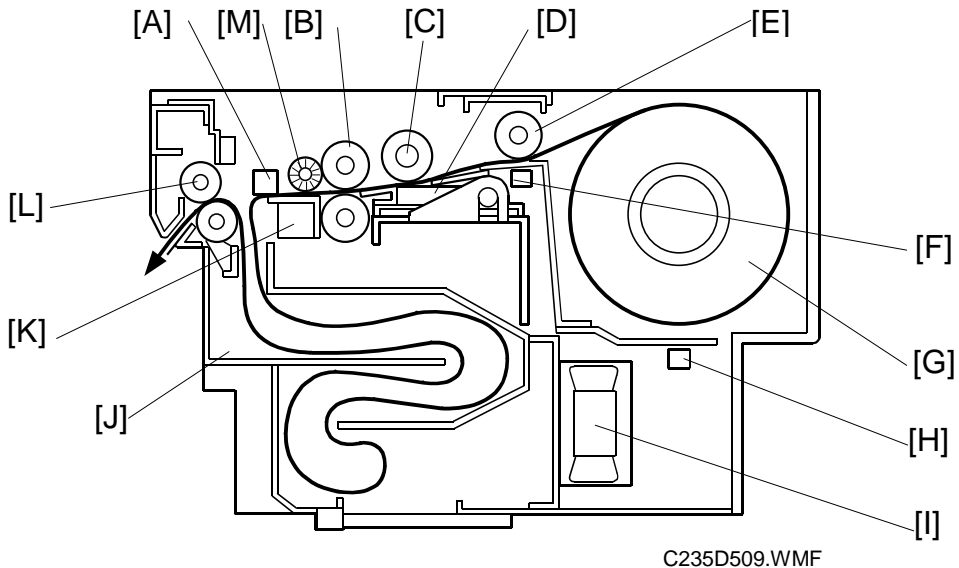

- |                       |                               |
|-----------------------|-------------------------------|
| A: Master Edge Sensor | G: Master Roll                |
| B: Tension Roller     | H: Master End Sensor          |
| C: Platen Roller      | I: Master Vacuum Fans         |
| D: Thermal Head       | J: Master Buffer Duct         |
| E: Master Set Roller  | K: Cutter                     |
| F: Master Set Sensor  | L: Master Feed Control Roller |
|                       | M: Anti-static Roller         |

Original scanning starts when an original is set and the Start key is pressed. Master making begins at the same time. Although master ejecting is done first, scanning starts very soon after.

The master is a low fiber content paper coated with a thin heat-sensitive film. The heating elements of the thermal head [D] burn the film to copy the scanned image.

The master is fed while the thermal head develops the image on it. The master vacuum fans [I] temporarily suck the fed master into the master buffer duct [J]. This is done because the used master is still being ejected from the drum. When the drum comes to the master making position, the master is fed to the drum and the drum master clamber on the drum clamps the master.

The drum then turns to wrap the master around the drum. When the master has been pulled out of the duct and is pulled tight at the cutter, the cutter [K] cuts the master.

At the same time as the master is wrapping, a sheet of paper, called the trial print, is fed. This ensures that ink transfers to the master on the drum, and that there is a sufficient density of ink for the print run to start. The drum then returns to the home position and is ready for printing.

## 2.4.2 MASTER SET MECHANISM

### ***Master Roll Set***

The master set sensor [A] checks to see if the master roll was installed properly. After inserting the master making unit, the sensor detects the leading edge of the master. The master is fed in until the leading edge reaches the master feed control roller.

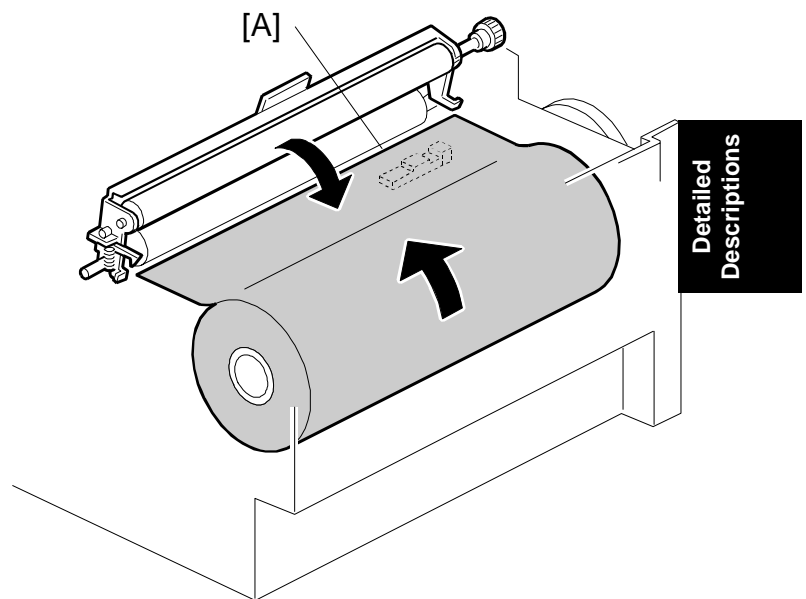

C235D102.WMF

### ***Master Feed and Stop Control (Edge Detection)***

While the master is being fed after a roll is put in the machine, the master edge sensor [B] checks the leading edge of the master.

The master is fed 20 mm more after the master edge sensor [B] is activated. It has now been caught by the master feed control roller [C] and it stops. This is the stand-by position for master making.

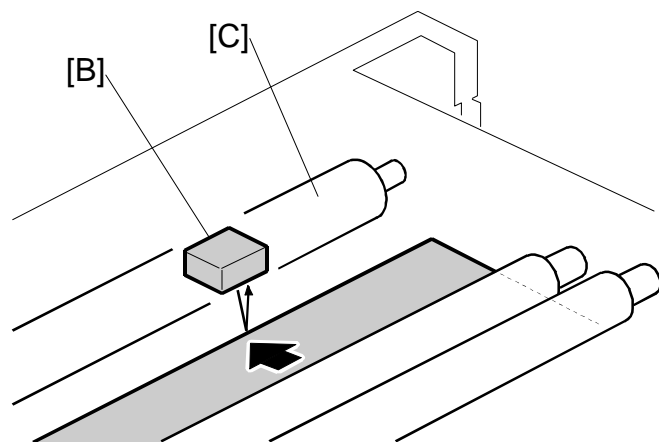

C235D103.WMF

While the master is fed, the platen roller pressure, which is used to press the master against the thermal head, is repeatedly applied and released using the platen pressure release mechanism. This prevents master skew or creasing after a roll has been put in the machine. A later section will describe this process in more detail.

**Master Buffer Duct Entrance Control**

While the master is being transported to the master feed control roller [A], the duct entrance solenoid [C] closes the master buffer duct entrance plate [B]. This prevents the duct entrance from catching the leading edge of the master.

After the master feed control roller [A] catches the master leading edge, the entrance plate is opened. (The normal position of the entrance plate is open.)

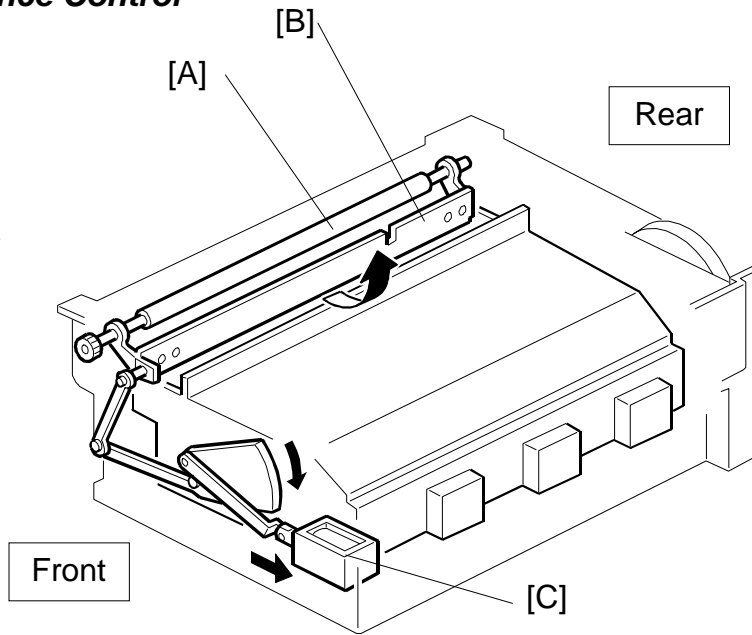

C235D004.WMF

**Master End Detection**

There is a solid-fill black area at the end of the master roll. When the master end sensor [D] detects this area, the operation panel displays the master end message.



As the master is semi-transparent, the sensor can detect the black area at the end of the roll when there are still a few layers of clear master on the roll. When this happens, master roll near-end is detected.

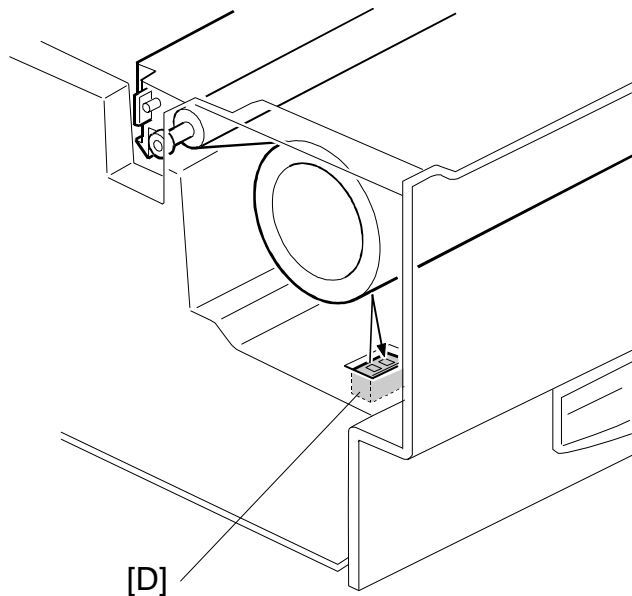

C235D104.WMF

## 2.4.3 MASTER MAKING AND FEED MECHANISM

### *Master Feed Mechanism*

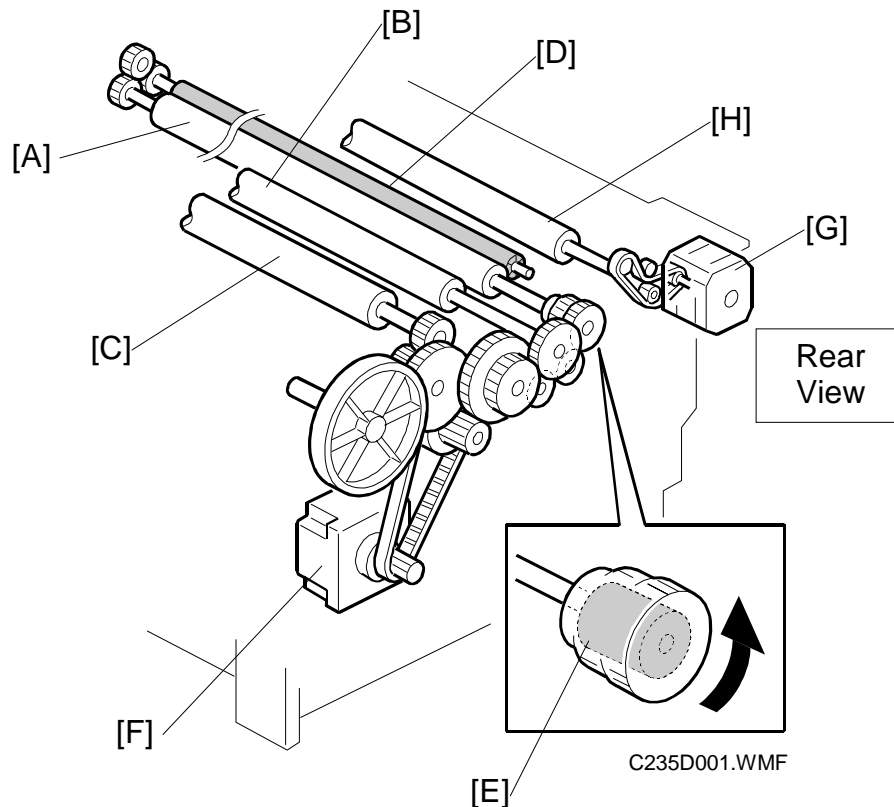

Detailed  
Descriptions

The master feed motor [F], a stepper motor, drives the tension [A], platen [B] and master set [C] and anti-static [D] roller.

The master feed control motor [G] drives the master feed control roller [H].

The tension roller feeds the master slightly faster than the platen roller, to prevent the master from creasing. Therefore, the master between the platen roller and thermal head is always under tension.

There is a torque limiter [E] built into the tension roller drive gear. This allows the tension roller to become free from the master feed motor drive when the master is under excessive tension, to prevent damage to the master.

**NOTE:** Strips of mylar under each master feed roller prevent the master from being wrapped around the rollers. Be careful not to damage or set the mylars in the incorrect position because they damage easily. For details, refer to the Replacement and Adjustment section.

**Platen Roller Pressure Release**

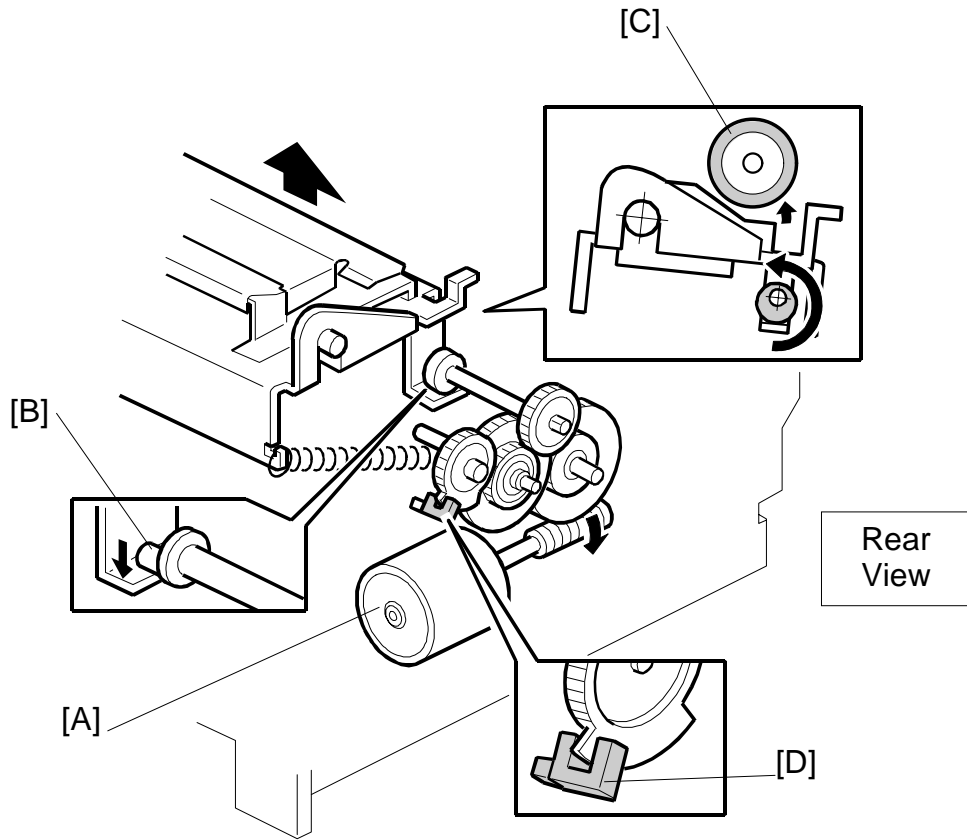

C235D202.WMF

The platen release motor [A] gives half a turn to the platen release cam [B] to apply or release the platen roller [C] pressure. As the motor turns, the actuator on the gear interrupts the platen release sensor [D]. When the pressure is released, the actuator interrupts the sensor.

**NOTE:** When installing the gear with the actuator, remember that the setting position depends on the platen release cam position. For details, refer to the Replacement and Adjustment section.

Just before master making, the platen release motor starts turning until the sensor is inactive; this indicates that the platen pressure is now applied to prepare for master making.

When master making is complete, the motor turns again until the sensor is activated, releasing the platen pressure. This allows the user to remove a jammed master. Also, in standby mode, there is no pressure between platen roller and thermal head, so that the user can take out the master.

As explained in “Master Feed and Stop Control,” the platen roller pressure is repeatedly applied and released to prevent master skew or creasing after a roll has been put in the machine. To do this, the motor continues turning for 3 seconds.

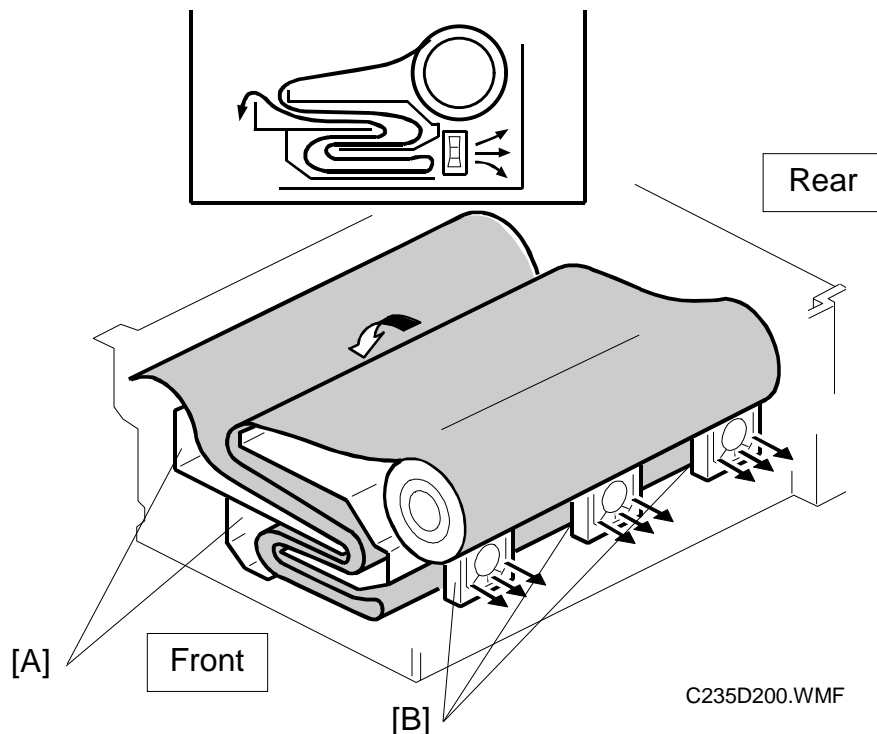

**Master Buffer Mechanism**Detailed  
Descriptions

To minimize master processing time, the master is stored in the master buffer duct [A] after the thermal head transfers the image to it. The stored master is fed out from the duct when the drum reaches the master making position after master ejecting.

The master buffer duct is located under the master feed path. A two-level chamber inside the duct can hold a sufficient length of the master for A3 printing.

As soon as master making starts, the three master vacuum fans [B] start turning, creating suction to guide the master into the duct [A]. At this time, the master feed control roller has already caught the leading edge of the master. This roller does not start turning until the drum reaches the master making position and the master clamper opens (because the master feed clutch disconnects the master feed motor drive).

The master is fed while the thermal head writes the image on it. As the leading edge of the master stops, the suction guides the fed master into the master buffer duct and stores it as shown in the above diagram.

When the drum comes to the master making position, the master feed control roller starts turning and feeds out the master that is stored in the duct.

**2.4.4 WRAPPING THE MASTER AROUND DRUM**

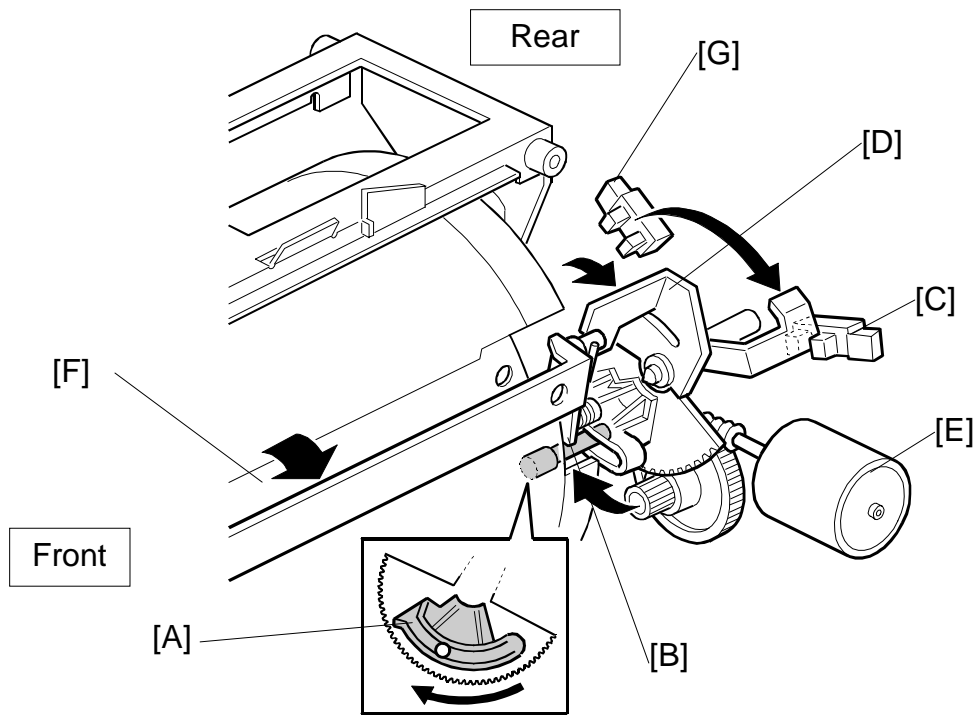

C235D091.WMF

***Drum Lock and Master Clamber Open***

As explained in the Master Eject section, the drum guide [A] holds the drum at the master eject and master making positions.

When the drum reaches the master making position, the drum guide moves to engage the stud [B] on the rear drum flange until the clamber open position sensor [C] is actuated. (The other stud was used for the master eject position.)

The master clamber opening arm [D] is just above the drum guide. The arm is different from the one used for opening the master clamber at the master eject position. The clamber motor [E] drives the arm and opens the master clamber [F], in synchronization with the drum guide movement.

The drum guide moves (to open the master clamber) until the clamber open position sensor is interrupted by the feeler. Then it stops immediately (unlike at the master eject position of the drum) as shown in the diagram.

Before the drum starts turning to start wrapping the master on the drum, the drum guide returns to the home position until the clamber close position sensor [G] is activated. The master clamber opening arm also returns, closing the master clamber.

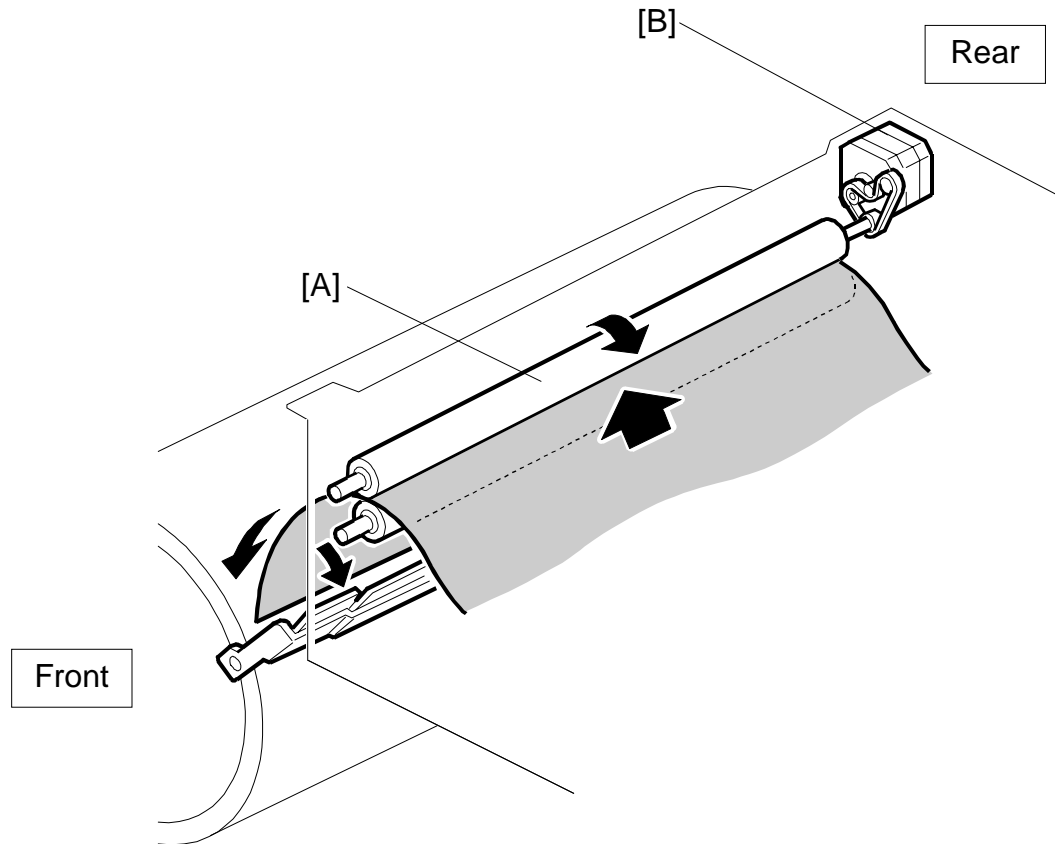
**Master Feed Control Roller Mechanism**Detailed  
Descriptions

C235D090.WMF

The master feed control roller [A] is driven by the master feed control motor [B] as shown. The master feed control roller turns in the following cases:

- When a master roll is put in the machine, the master is fed until the master feed control roller catches the leading edge of the master.
- During master clamping, the master feed control roller turns and sends the leading edge to the clamber position.
- While the master is being wrapped around the drum, the master feed control roller turns to feed the master, in synchronization with the drum rotation.

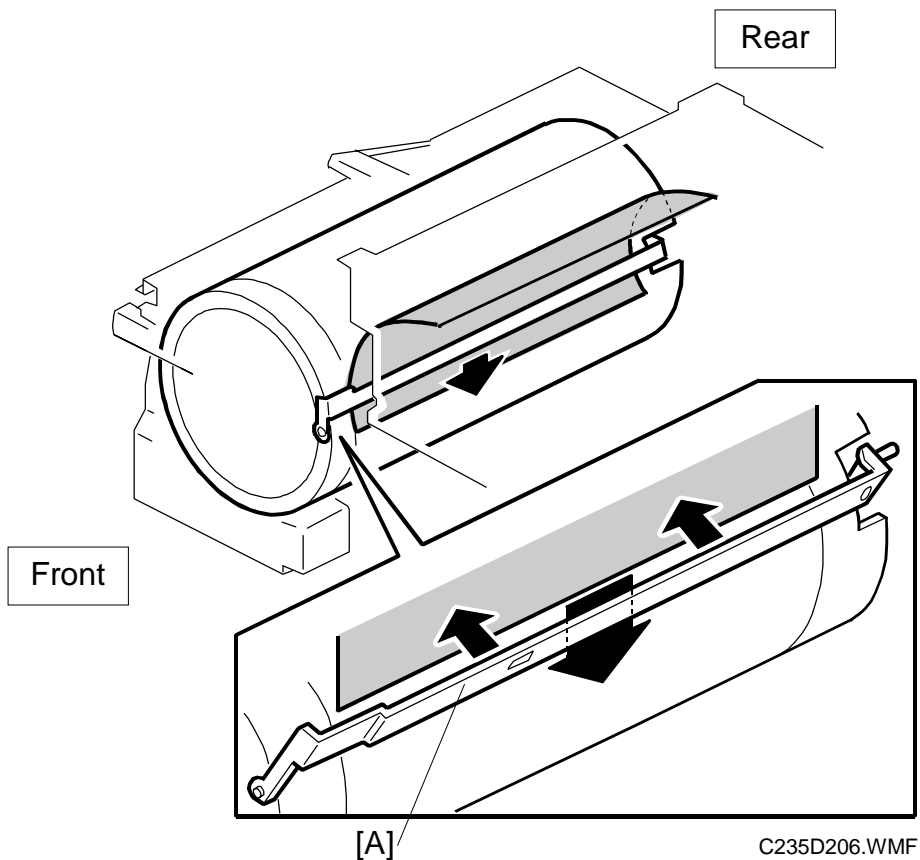
**Master Clamping and Wrapping around the Drum**

The master feed control motor turns on to feed out the master from the master buffer duct. The master is fed out 31 mm and reaches the drum master clamber [A]. The master feed control motor turns off temporarily.

The master clamber is closed and the drum starts turning to wrap the master around the drum. At the same time, the master feed control motor turns on again to feed the master, synchronizing it with the drum rotation.

When master making is complete and the master is stored in the master buffer duct, the drum turns continuously to wrap the master. The cutter cuts the master when there is no master left in the duct, and the master at the cutter is stretched tightly; this ensures a clean cut.

A sheet of paper, called the trial print, is fed at the same time as the master wrapping. To ensure that ink transfers to the master on the drum, the drum rotates at its lowest speed (16 rpm). This ensures that the print run starts up with a sufficient ink density.

The drum then returns to the home position, ready for printing.

**Master Cut and Buffer Duct Entrance Control**

When the thermal head has finished making the master and the master has been fed out of the duct, the cutter [A] will cut the master.

In preparation for making the next master, the leading edge of the next master is continuously fed to the master feed control roller [B].

The new master is fed 30 mm past the cut position and stopped.

**NOTE:** As explained in “Master Feed and Stop Control in 2.5.2 Master Set Mechanism,” the master edge sensor only controls the master stop position at the master feed control roller after a roll is put into the machine.

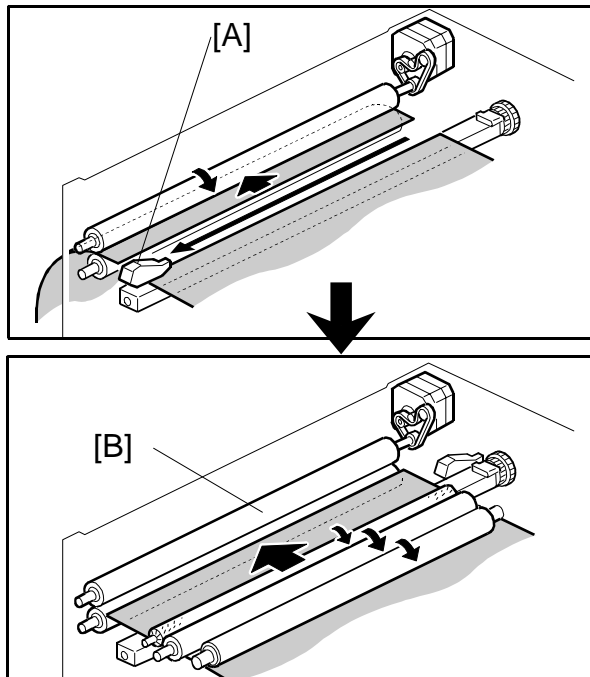

C235D506.WMF

Detailed Descriptions

The duct entrance plate stays open, except in the following two cases. To close off the duct, the duct entrance solenoid closes the master buffer duct entrance plate [C].

- While the leading edge of the next master is being fed to the master feed control roller [B]
- After a roll is put in the machine (as explained in "2.5.2 Master Set Mechanism").

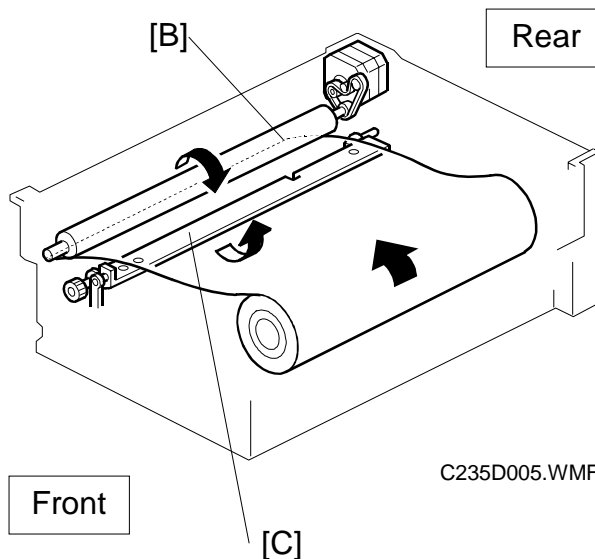

C235D005.WMF

**Cutter Mechanism**

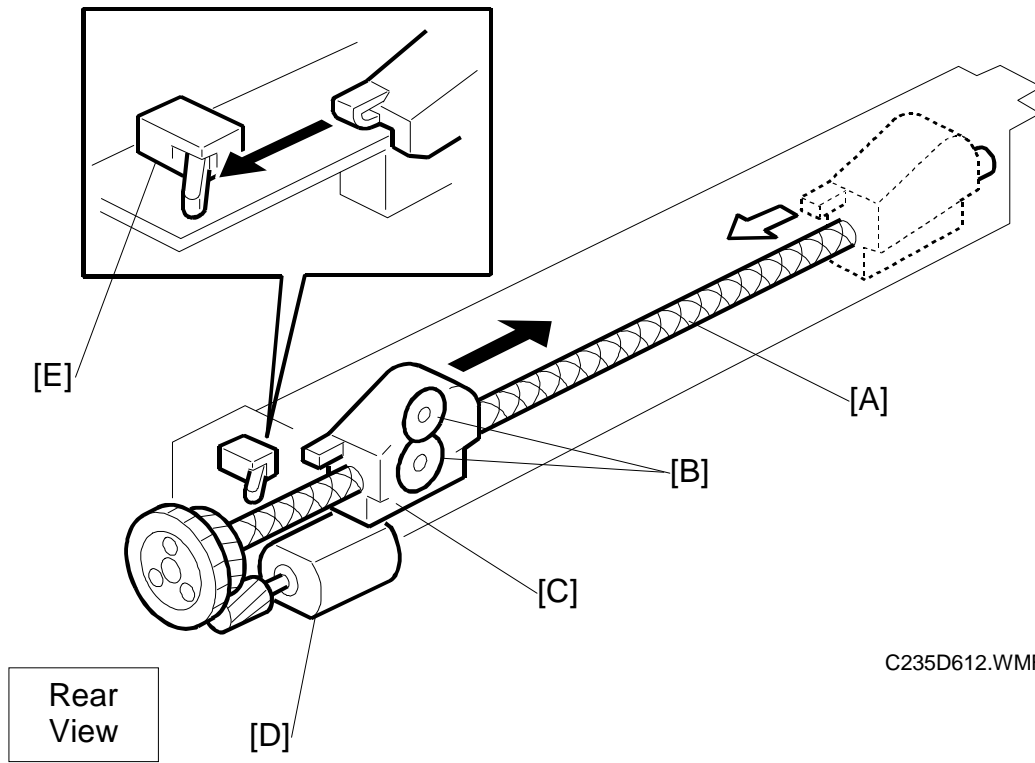

The cutter motor [D] drives the screw shaft [A], moving the cutter holder [C] forward and backward.

There are two cutter blades [B] in the holder. While the cutter holder [C] travels to the front (the operation side of the machine), the blades cut the master. The cutter motor keeps turning in one direction. However, the cutter holder returns to the home position when it reaches the front end of the cutter unit because of the two different spirals threaded on the screw shaft [A].

When the cutter holder reaches the home position, the cutter home position sensor [E] is activated by the holder and the motor stops.

## 2.4.5 MASTER MAKING UNIT SLIDE-OUT MECHANISM

The master making unit can be slid out along the guide rails.

There are three connectors, which enable electrical contact for the installed unit.

The master making unit set sensor [A] (a push switch) detects when the unit is out. The operation panel displays a message in this case.

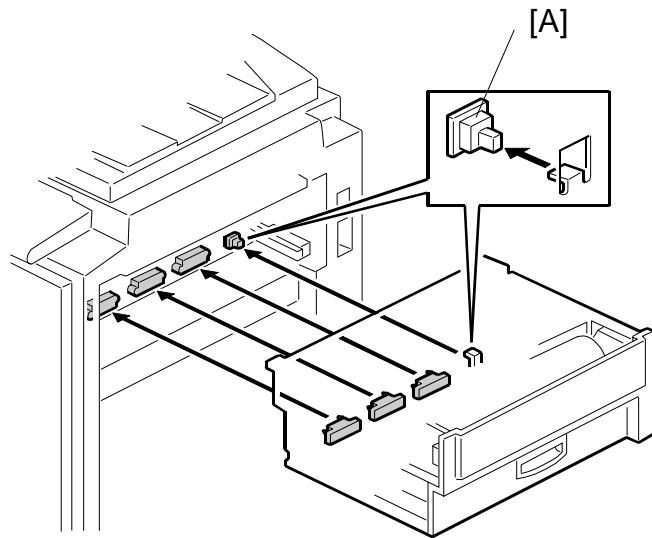

C235D100.WMF

## 2.4.6 OPENING DOOR FOR MISFED MASTER REMOVAL

There is a jam removal dial to manually rotate the master feed rollers. If pieces of the master remain in the master buffer duct, open the door [B] to remove them. Normally, pieces of master do not remain in the duct. Therefore, the door is only for emergency cases.

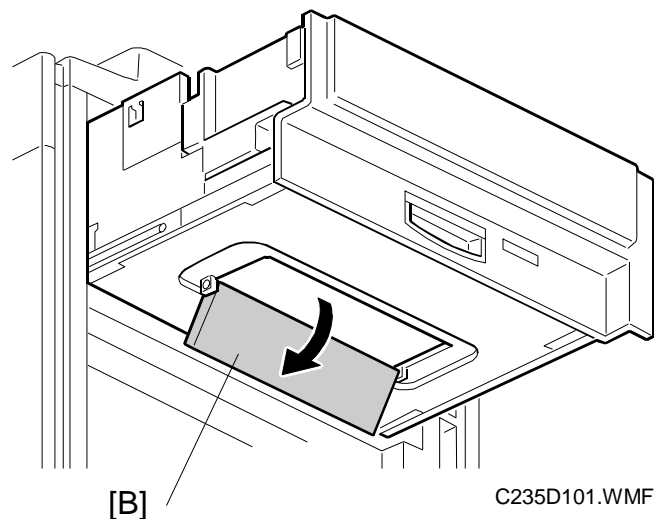

C235D101.WMF

## 2.5 DRUM

### 2.5.1 OVERVIEW

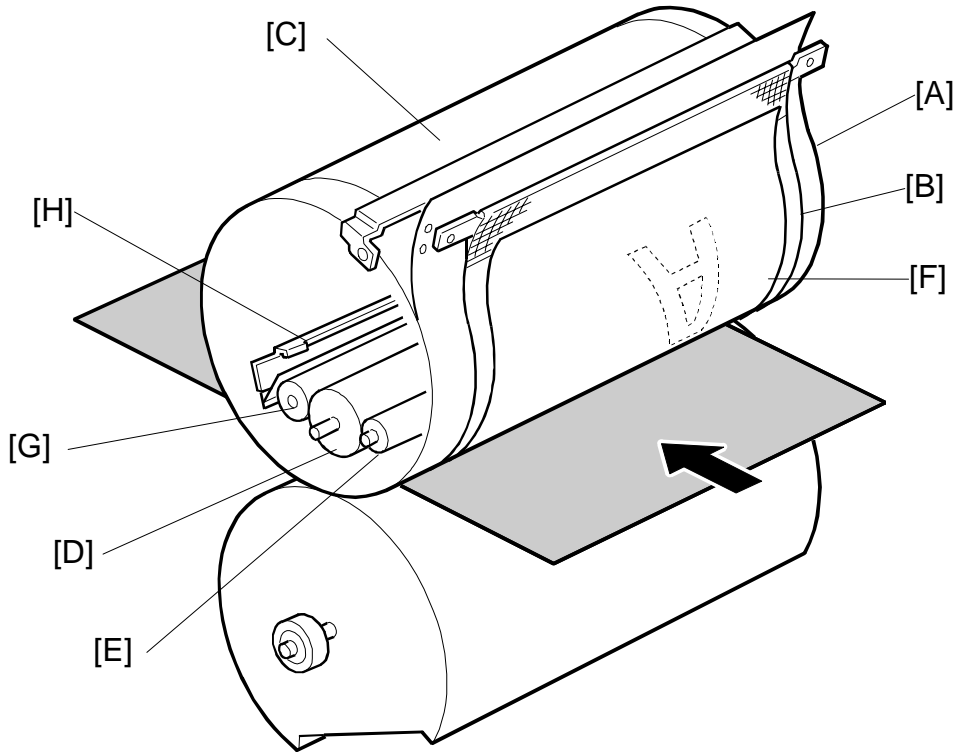

C235D501.WMF

The drum surface is composed of a stainless-steel screen (metal screen [A]) and one layer of polyester screens (cloth screen [B]). In addition, a drum master clammer [C] clamps the leading edge of the master wrapped around the drum.

Inside the drum are the ink roller [D] and doctor roller [E], which create a precisely maintained gap, known as the doctor gap, to supply a thin layer of ink on the screens and master [F].

This machine uses the drum idling roller [G] to supply ink onto the screens and master before printing. The length of time the machine was not in use determines the idling supply time. This ensures that the first print will have sufficient ink density even after the machine was not used for a long time.

The quality blade [H] inside the drum scrapes off excess ink inside the metal screen. This mechanism helps to reduce excess ink on the paper. For more details on this mechanism, see Drum Idling Mechanism.

The quality blade is always operating during quality start mode. Also, it automatically starts just before the machine enters energy saving mode. (The operator can enter energy saver mode manually by holding down the mode clear key for more than 5 seconds.)



## 2.5.2 INK SUPPLY AND KNEADING MECHANISM

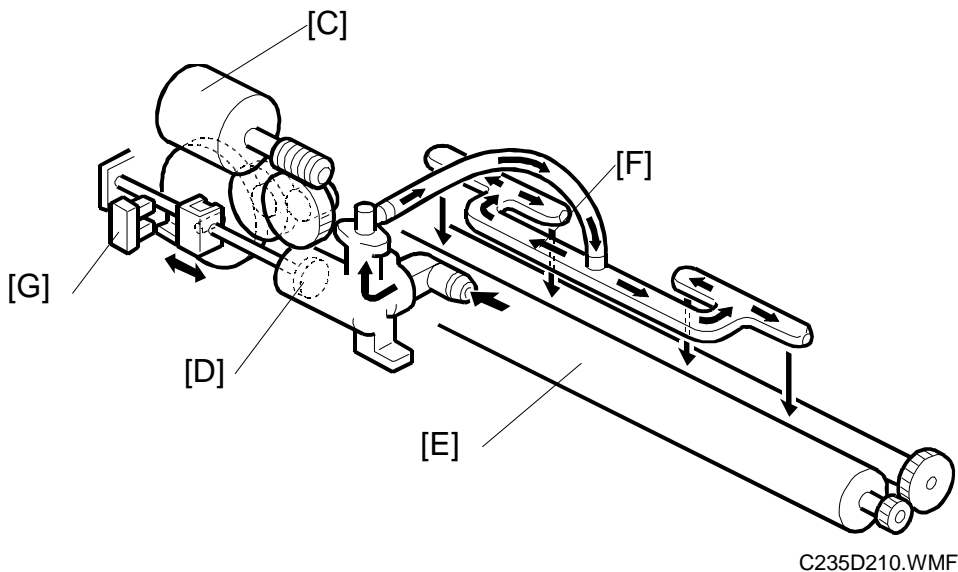

Detailed  
Descriptions

### ***Ink Cartridge Installation***

The ink cartridge [A] is in the drum. The ink cartridge set sensor [B] (a push switch) detects the presence of the ink cartridge.

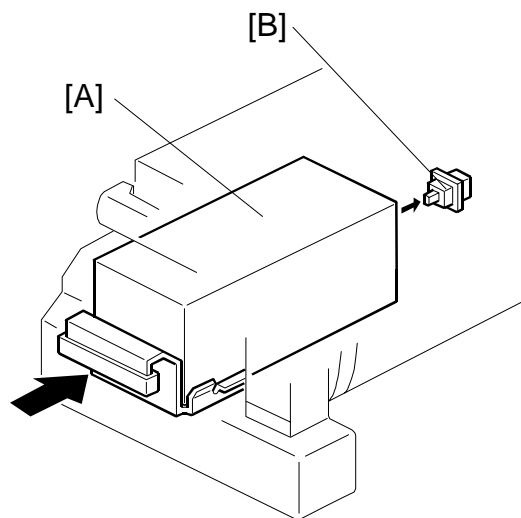

### ***Ink Supply Mechanism***

The whole ink supply mechanism is inside the drum. The ink pump motor [C] drives the ink pump [D], supplying ink from the ink cartridge to the ink roller [E] via the ink distributor [F].

### ***Ink Pump Operation Monitoring***

The ink pump sensor [G] monitors the number of pumps the ink pump piston lever makes. The feeler on the piston lever activates the sensor at each complete turn of the piston.

SP1-5 can be used to check the number of ink pump revolutions.

***Ink Detection Board***

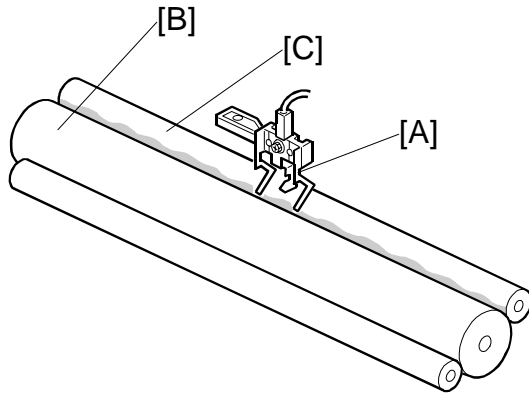

C235D515.WMF

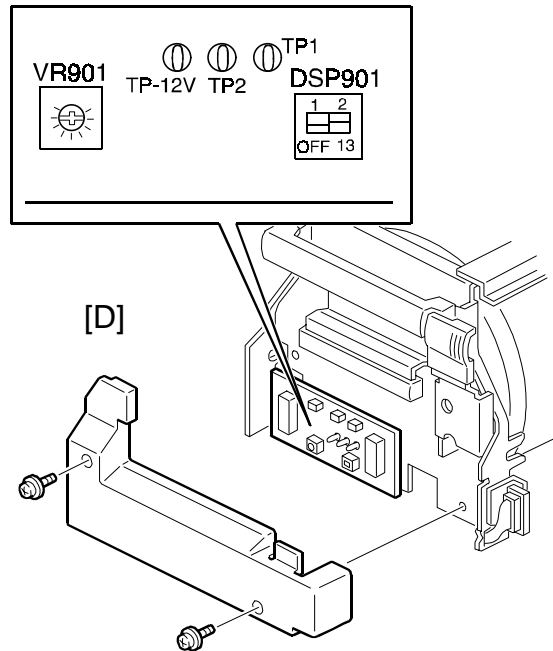

C235D211.WMF

***Ink Detection Mechanism***

The ink detecting pins [A] function as a capacitor electrode and detect the capacitance between the ink [B] and doctor [C] rollers. The capacitance level changes with the ink level. When the ink level is high the pins touch ink, and the capacitance increases. When the ink level is low the pins do not touch the ink and the capacitance therefore decreases. Consequently, by detecting the capacitance between the pins, the ink supply motor maintains the ink level.

If the pins detect an insufficient amount of ink after activating the ink pump motor for 40 seconds, a "no ink condition" is detected. Guidance is displayed on the operation panel.

**NOTE:** The ink supply mode is useful when installing a new drum. When the "Economy Mode" key is pressed while holding down the "0" key, the drum turns 40 rotations, to supply ink inside the drum.

The ink detection board [D], which includes the ink detection circuit, is also inside the drum. There are test pins (TP's) and a potentiometer (VR901) for ink detection adjustment.

***Drum Type Detection***

There are also dip switches on the ink detection board. The settings depend on the drum type in the following manner:

<b>DPS901</b>	<b>-1</b>	<b>-2</b>
Standard Drum	ON	ON
Optional Color Drum	OFF	ON
Optional A4 Drum	ON	OFF
Not Used	OFF	OFF

Detailed Descriptions

If the CPU detects that all dip switches are off, it assumes that there is no drum in the machine.

***Ink Kneading Mechanism***

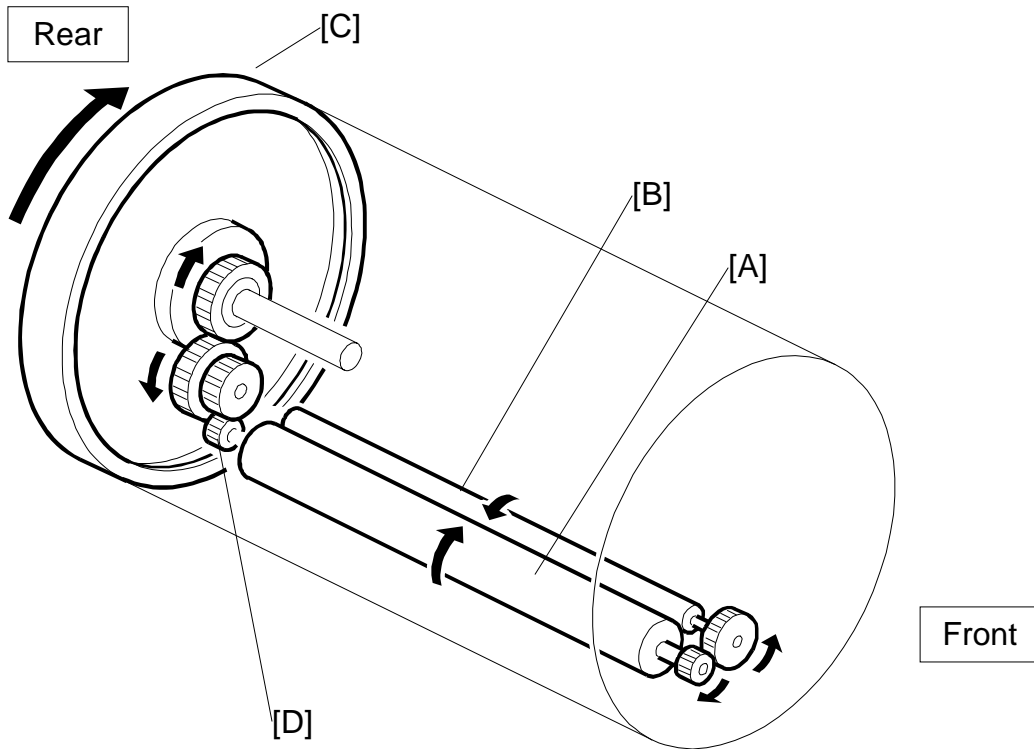

C235D207.WMF

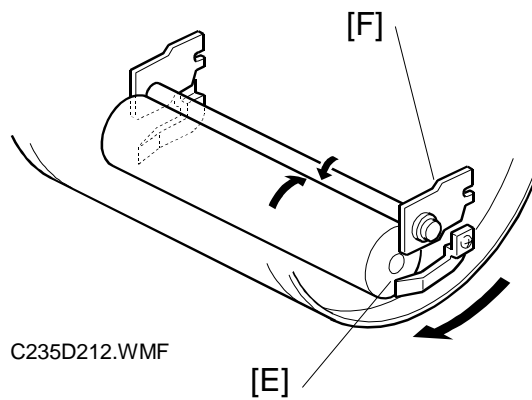

C235D212.WMF

A gear [C] on the drum shaft drives the ink [A] and doctor [B] rollers. The doctor roller spreads the ink evenly on the ink roller. The ink roller drive gear [D] has a one-way clutch to prevent the ink roller from being manually turned in the reverse direction.

The ink roller only touches the screen during the printing process. During the printing process, ink passes to the paper through holes in the screens and the master. This is because the pressure cylinder below the drum holds the drum screen and the master against the ink roller during printing.

The ink roller blade [E] and separation plate [F] scrape off ink build-up on both ends of the ink and doctor rollers.

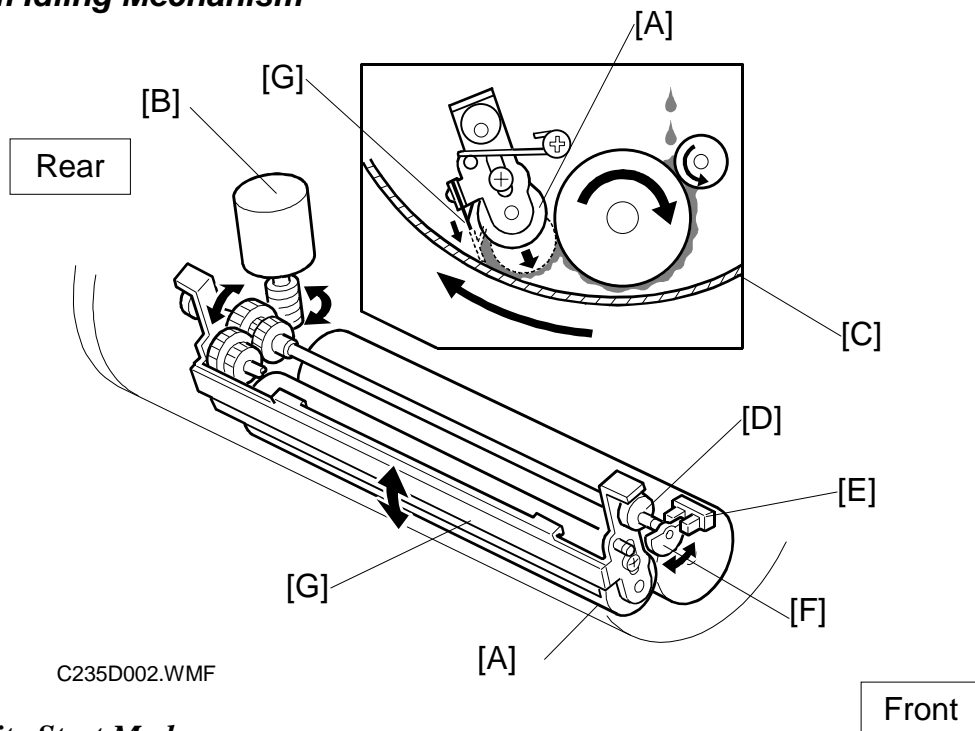
**Drum Idling Mechanism**Detailed  
Descriptions**Quality Start Mode**

In Quality Start mode; the machine enters the drum idling mode before printing. This ensures that the first print has sufficient ink density even if the machine was not used for a long time.

The user selects Quality Start mode by pressing a key on the operation panel. The number of idling rotations is fixed at 7. However, user tool 4-12 can change this number.

**NOTE:** In Quality Start mode; the drum idling motion starts before printing, when the Start key is pressed. However, if there is no master on the drum, drum idling is not done.

Even if the Quality Start mode is active, and there is no master on the drum, drum idling is skipped although the LED on the operation panel turns on. When printing for the next original starts, the machine enters drum idling mode if a large enough master is wrapped around the drum (it will not be done for an A4 master on an A3 drum).

The drum idling roller [A] and quality blade [G] put the ink onto the screen and master before printing. The idling roller motor [B] turns to press the drum idling roller and the quality blade against the inner surface of the drum screen [C]. The quality blade scrapes off excess ink inside the metal screen. A spring under tension supplies additional force for this.

The motor turns the cam [D], moving the drum idling roller and quality blade into contact and away from the drum screen. The actuator disk [F] interrupts the idling roller HP sensor [E] when the drum idling roller and quality blade are in contact with the drum screen.

***Auto Quality Start Mode***

Auto Quality Start is done if the user does not select Quality Start mode. (It can be disabled with a user tool.)

In Auto Quality Start mode, the idling motion depends on how long the machine was not in use and on the temperature detected by the thermistor [A] in the drum.

The CPU detects a low temperature condition if the thermistor [A] reports approximately 15 °C or lower. If the detected temperature is 28 °C or higher, it is a high temperature condition.

The number of drum idling rotations depends on temperature and period of machine inactivity, as shown in the following table.

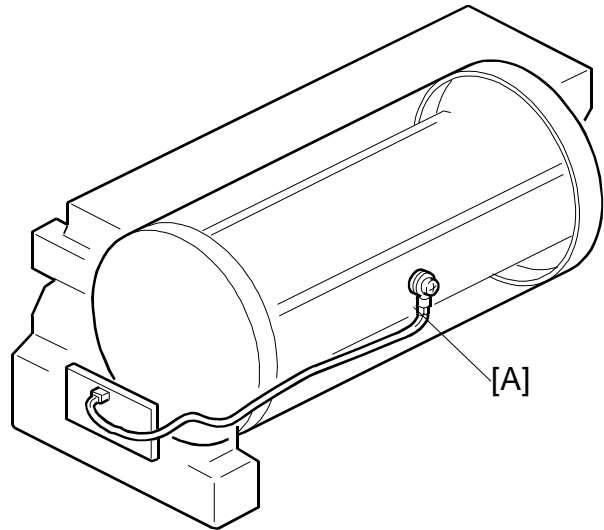

C235D111.WMF

**NOTE:** User Tools 4-14 can change the number of rotations for each of these conditions.

<b>Period/ Temperature</b>	<b>Less than 4 hours</b>	<b>4 to 24 hours</b>	<b>24 to 72 hours</b>	<b>Over 72 hours</b>
High (28 °C or higher)	0	5	5	5
Normal (15 to 28 °C)	0	5	5	5
Low (15 °C or lower)	0	7	7	7

**NOTE:** The drum rotation speed during idling is fixed at 90 rpm.



**Drum Rotation Speed during *Printing***

When the machine is in Quality Start mode, the drum idling roller is always used for drum idling mode. When the machine is printing (Trial print, 1st print, 2nd print ... ), the drum idling roller is not used.

The drum rotation speed varies during **printing** as shown in the table below.

**- Change of drum rotation speed (rpm) with temperature -**

Temperature	Trial Print	1st Print	2nd Print	3rd Print	4th Print	5th Print	6th Print	7th Print
High (28 °C or above)	16	90	105	120	120	120	120	120
Normal (15 °C ~ 28 °C)	16	75	90	105	120	120	120	120
Low (below 15 °C)	16	30	60	75	90	105	120	120

Detailed Descriptions

**NOTE:** These figures apply to the highest printing speed (speed 5, which is at 120 rpm).

### 2.5.3 DRUM SHIFT MECHANISM FOR IMAGE SIDE-TO-SIDE SHIFT

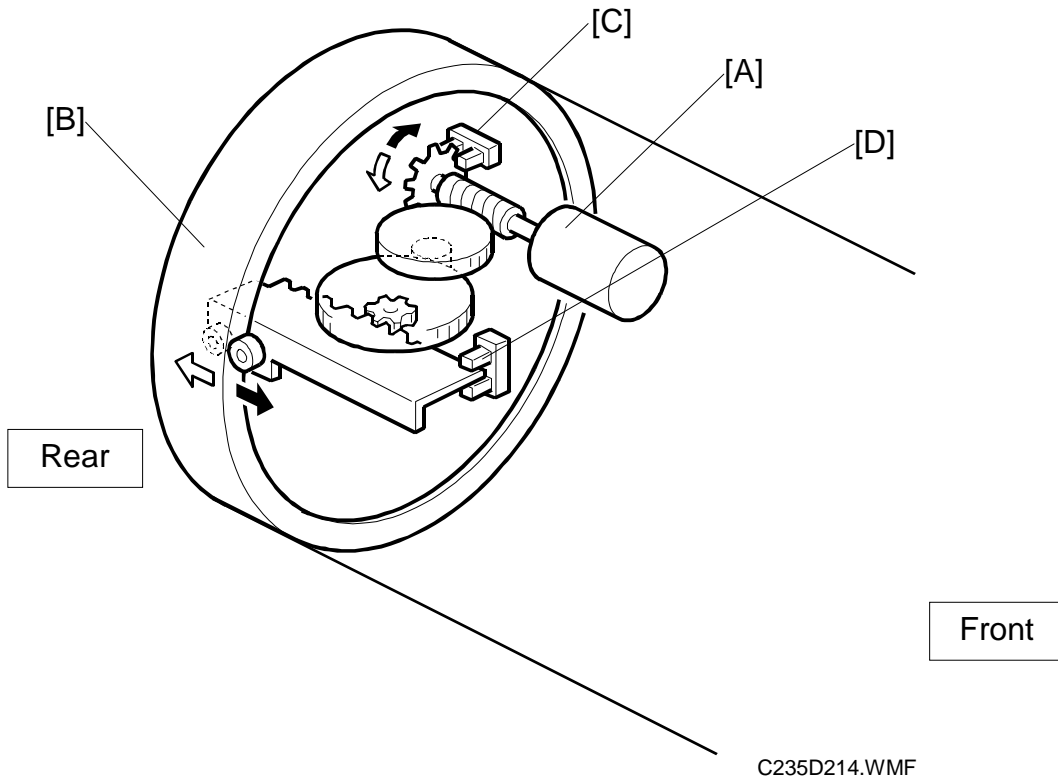

The image side-to-side shift function shifts the outer drum sleeve (with master) from front to back.

The shifting mechanism is inside the drum. It consists of the drum shift motor [A] and a rack and pinion mechanism.

The motor can turn in either direction by the image shift amount set at the operation panel. The motor moves the rear drum flange [B] via the rack and pinion, as shown. At the same time, it rotates the pulse disk. This allows the drum shift sensor [C] to generate pulse signals for sending to the CPU. The CPU detects the amount of shift with these signals and controls motor on/off time.

The maximum shift range, in both directions, is 10 mm from home position. The drum shift HP sensor [D] ensures that the outer drum sleeve returns to the home position.

When the outer sleeve returns to the home position, it activates the sensor, stopping the drum shift motor.



### 2.5.4 DRUM SET MECHANISM

#### **Upper Handle and Lock**

There are two grips [A, and B] to hold the drum.

When the upper grip [A] is pulled up, it releases the drum locking mechanism.

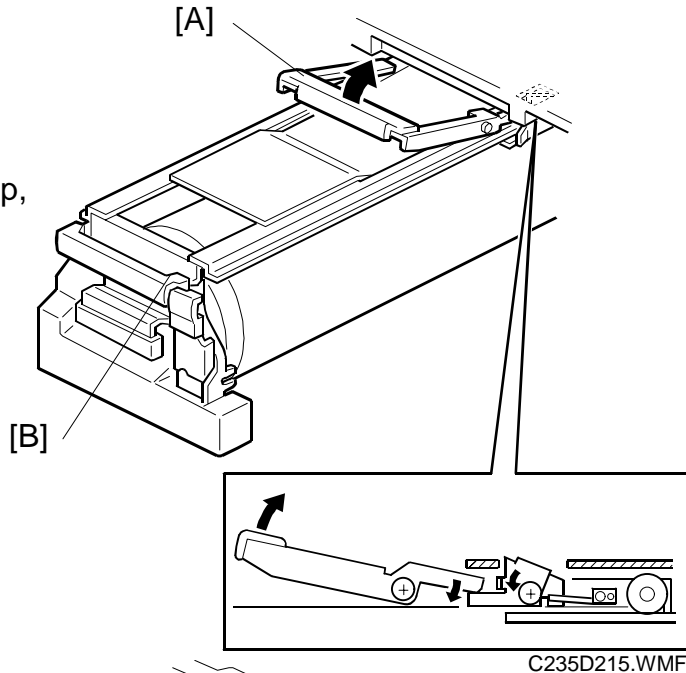

Detailed Descriptions

#### **Front Lock Lever**

When the drum is set correctly and the front lever [C] is raised, the drum is locked into position. The connector [D] allows electrical contact for the drum components.

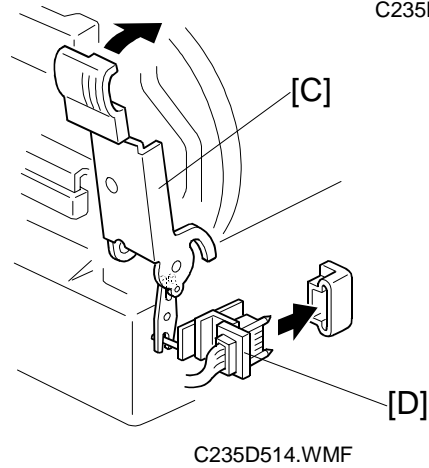

#### **Drum Rotation Lock Mechanism**

The rotation stopper [E] prevents the drum from turning when it is removed from the machine.

When the drum is replaced, contact with the rear frame disengages the stopper [E] and releases the lock.

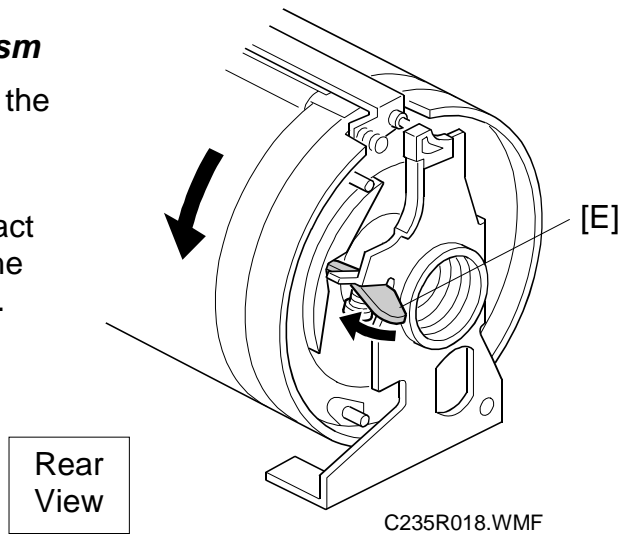

Rear View

### 2.5.5 DRUM DRIVE MECHANISM

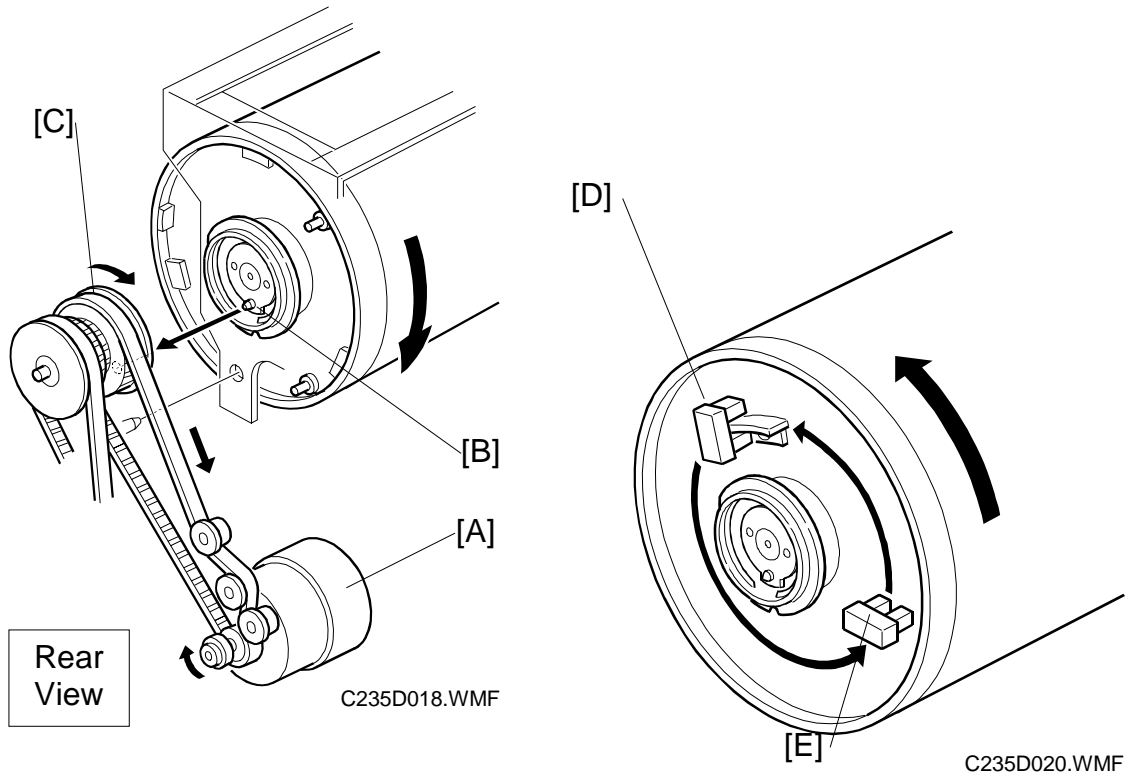

The main motor [A] drives the drum via the timing belt. When the drum is set in the machine, the stud [B] on the joint disk engages the drum drive gear [C]. This transmits the main motor drive to the drum unit.

The main motor [C] has an encoder to send pulses to the main motor control board. The CPU monitors the pulses and controls the drum speed and stop positions. The 1st and 2nd drum position sensors [D, E] check the position of the drum. The actuator on the rear drum flange activates these sensors as the drum turns.

There are three drum stop positions: home, master eject, and master making. The CPU starts counting the main motor encoder pulses when these sensors are activated. Certain pulse counts are assigned to each drum stop position. The CPU can stop the drum at the desired positions.

At the home and master making positions, the drum de-actuates the relevant sensor. This ensures that the drum stops in the exact position, even after high-speed rotation. The 1st drum position sensor corresponds to the home position and the 2nd drum position sensor corresponds to the master making position.

## 2.5.6 MASTER DETECTION

The 1st drum master sensor [A] detects a master on the drum.

If a master is on the drum, the black patch [B] is covered and the sensor detects the light reflected from the master. Printing starts when the start key is pressed. If an original has been set, the old master is ejected from the drum before making a new master.

If no master is on the drum, the black patch is exposed. The black patch does not reflect light back to the sensor. The machine will skip the master eject process and immediately begin making a new master.

A similar sensor, the 2nd drum master sensor [C], is located just above the 1st drum master sensor. This sensor determines if the master making process correctly wrapped the master around the drum.

The drum starts turning soon after the drum master clamber clamps the leading edge of the master. The 2nd drum master sensor checks for the presence of the master (master clamping error check). If a master is not detected, a clamping error occurred. The master feed stops, the drum returns to the home position, and the machine displays a master feed jam message.

The 1st drum master sensor cannot check for master clamping errors, because the black patch has moved.

Both sensors use the same black patch [B] to detect the master.

**NOTE:** In this model, the black patch on the drum is larger.

The patch ensures that the master pick-up roller in the master eject roller unit contacts the drum surface evenly at this part of the drum, resulting in even pressure from the roller all across the drum.

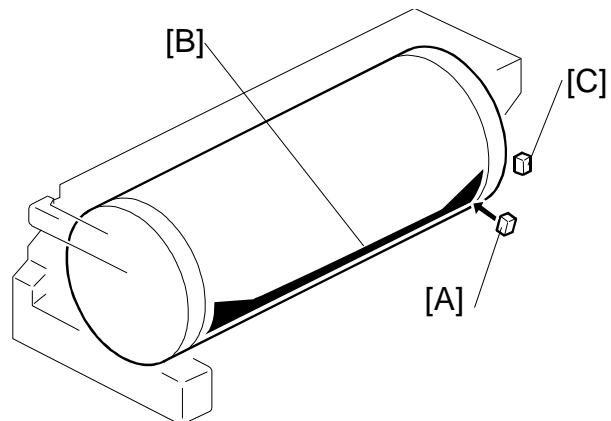

C235D502.WMF

## 2.6 PAPER FEED

### 2.6.1 OVERVIEW

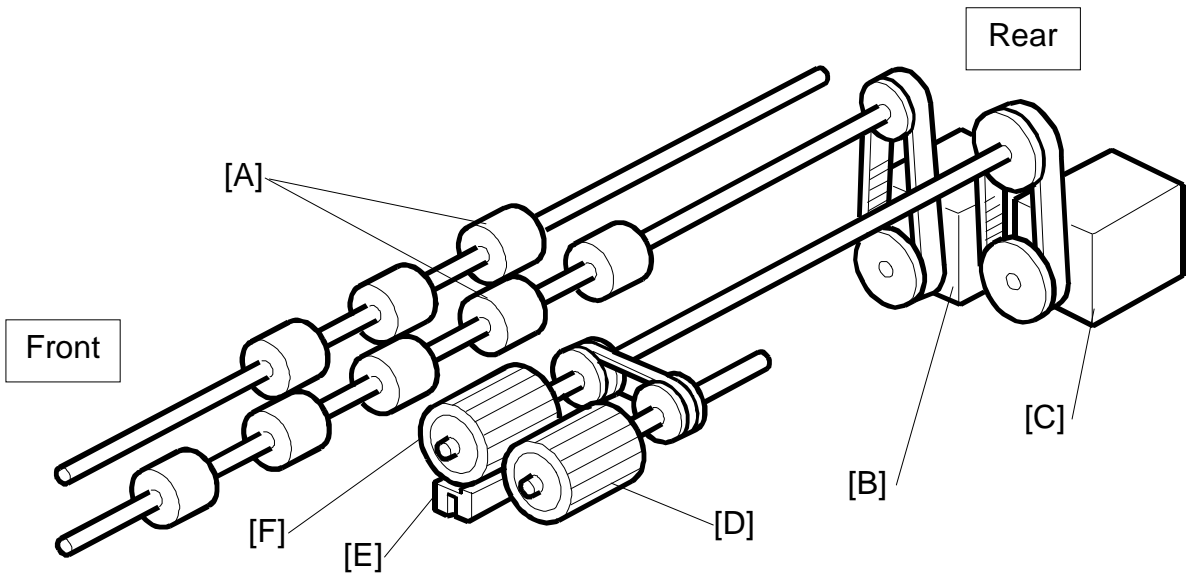

C235D053.WMF

#### ***Pick-up and Feed***

The top sheet of paper on the paper table is first fed by the pick-up roller [D]. Then, it is separated by the paper feed roller [F] and the friction pad [E], and fed to the registration rollers [A]. The upper and lower registration rollers feed the sheet to the drum.

An independent stepper motor (the paper feed motor [C]) drives the pick-up roller and paper feed roller. This allows more precise control than the usual main motor/magnetic clutch system.

#### ***Feed/Separation Pressure***

The strength of the paper feed roller and the friction pad pressure against the paper depend on the paper type selected at the operation panel. Each component has a separate dc motor to adjust the pressure. The operator is free from complicated adjustments for paper feed and paper separation pressures.

#### ***Registration***

Also, an independent stepper motor (the registration motor [B]) controls the registration roller. The registration roller synchronizes paper feed timing with the image on the drum. The registration roller starts rotating after the paper has come in contact with the rollers and has been aligned.

Paper feed timing around the registration roller is monitored by two different photo-sensors. One is located before the registration roller, and the other is after the registration roller. These sensors are also essential for paper feed control.

### 2.6.2 PAPER FEED MECHANISM

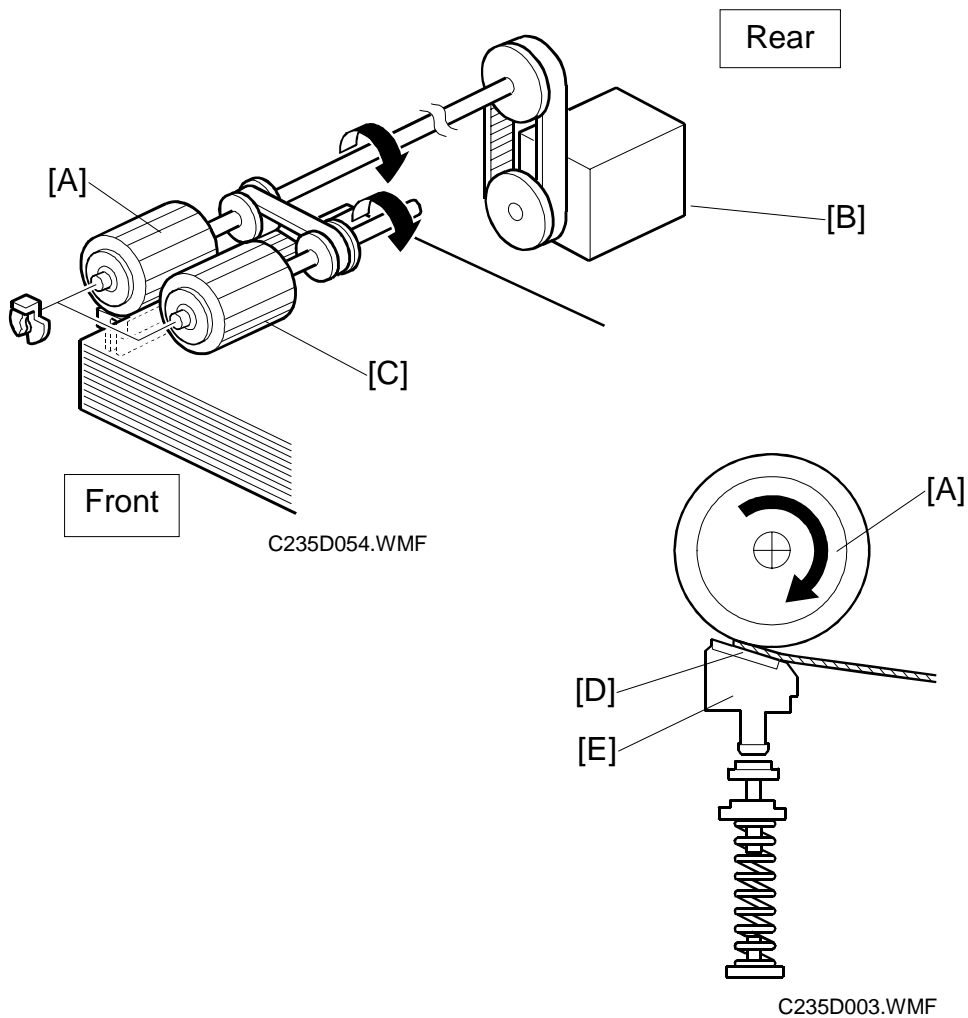

Detailed Descriptions

The pick-up roller [C] and paper feed roller [A] are driven by the paper feed motor [B] as shown.

The top sheet of the paper is separated from the paper stack by the friction between the roller and the friction pad [D], and fed to the registration roller.

The friction pad [D] is mounted on a block [E], and spring pressure is applied to this block. As explained later, the spring pressure is changed by a dc motor to adjust the paper separation pressure.

There is a one-way clutch in the paper feed roller. When the roller stops and paper is fed by the registration rollers, the one-way clutch ensures that the paper feed roller does not resist the paper feed.

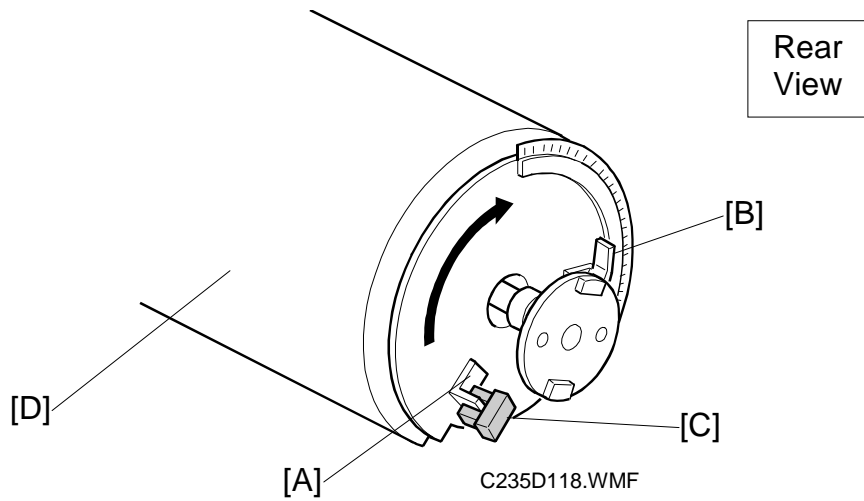

Since paper feed timing must be synchronized with pressure cylinder rotation (so that the paper clamber on the pressure cylinder can catch paper's leading edge accurately), the paper feed motor on timing is maintained by the feed start sensor [C].

A short time after the pressure cylinder [D] starts rotating, the actuator [A] on the rear of the pressure cylinder activates the sensor. After a pre-determined duration, the paper feed process begins (this time will vary with the printing speed).

**NOTE:** There are two actuators: [A] and [B]. The actuator [B] is used to maintain the registration motor start timing.

## 2.6.3 PAPER FEED/SEPARATION PRESSURE ADJUSTMENT MECHANISM

### Overview

The paper separation pressure, the paper feed pressure and the friction pad that is used for separation depend on the paper type selected at the operation panel. When the paper type is changed, the three motors automatically turn to change the pressure settings and friction pad block.

Detailed  
Descriptions

### Paper Separation Pressure

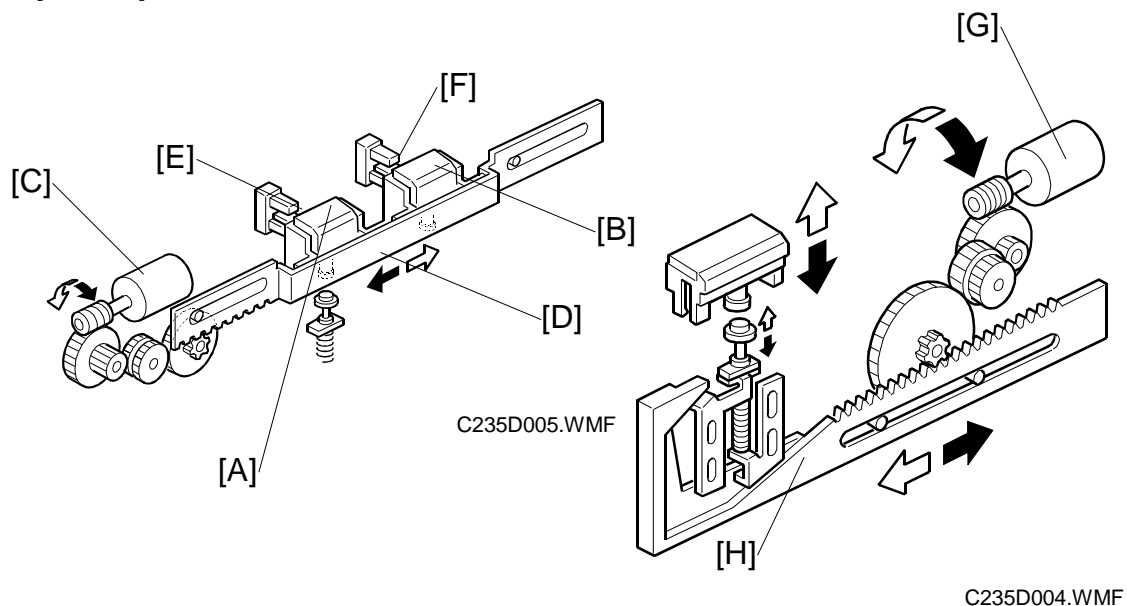

The friction pad ([A] or [B]) that is used depends on the paper type setting, and the settings of SP 6-011.

To use the normal pad [A], the friction pad shift motor [C] drives the rack [D]. When friction pad position sensors 1 [E] and 2 [F] are both actuated, the friction pad shift motor stops.

To use the custom pad [B], the friction pad shift motor [C] drives the rack [D]. When only friction pad position sensor 1 is actuated, the friction pad shift motor stops.

The direction of paper separation pressure motor [G] rotation depends on the signal from the CPU. The rack [H] moves from side to side, moving the friction pad base up or down. This changes the spring pressure against the friction pad block.

**Paper Feed Pressure**

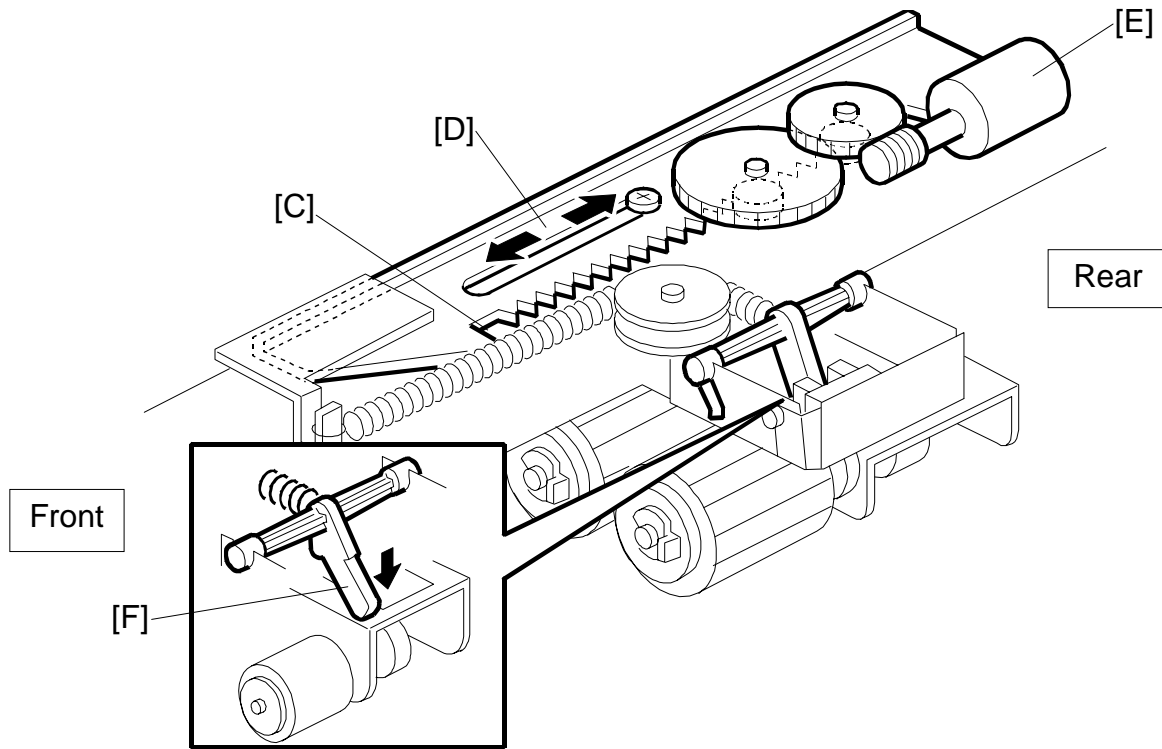

C235D055.WMF

The mechanism is similar to the separation pressure control mechanism.

The feed pressure motor [E] rotates, pulling or releasing the spring [C] through the rack [D]. The lever [F] moves up or down depending on the tension of the spring. If the spring is pulled, the lever moves upwards, reducing the paper feed pressure.

The position of the rack [D] is detected by the feed pressure detection board (not shown), in a similar way as in the paper separation pressure control mechanism.



## ***Paper Types***

The user can select the paper type before starting the job. The feed and separation pressures used for the job will depend on the selected paper type. The machine automatically adjusts these pressures to suit the selected paper type .

The possible paper type settings are standard, thick, and special. Two additional settings for paper types ('user 1' and 'user 2') can be customized.

For the 'user 1' and 'user 2' paper types, the user can choose from 5 settings with a user tool. The user tool settings give the machine a rough idea of what type of paper the user is using as types User 1 and User 2. The five user tool settings are as follows.

- Standard, no feed (Standard paper type, non feed likely)
- Standard, double feed (Standard paper type, double feed likely)
- Thick, no feed (Thick paper type, non feed likely)
- Thick, double feed (Thick paper type, double feed likely)
- Thick, medium (Thick paper type, with intermediate chances of double and non-feed)

## ***Pressure Settings for Each Paper Type***

For each of these paper types (standard, thick, special, user 1, user 2), the user has two settings: 'Misfeed' and 'Double Feed'. Each of these two settings has three possible values: Standard, Frequent, Very Frequent (the user selects one of these depending on how the machine is performing).

The pressures for each setting can be adjusted with SP mode (SP 6-009 and SP 6-010).

The 'feed pressure' SP modes adjust the feed pressures applied for each of the user's three possible 'misfeed' settings, and the 'separation pressure' SP modes adjust the separation pressures applied for each of the user's three possible 'double feed' settings. For how to use these SP modes, refer to the Replacement and Adjustment section.

- SP6-009-1 to 3 : Feed pressure, normal paper
- SP6-009-4 to 6: Feed pressure, thick paper
- SP6-009-10 to 12: Feed pressure, special paper
- SP6-009-13 to 15: Feed pressure, user 1 paper
- SP6-009-16 to 18: Feed pressure, user 2 paper
- SP6-010-1 to 3: Separation pressure, normal paper
- SP6-010-4 to 6: Separation pressure, thick paper
- SP6-010-10 to 12: Feed pressure, special paper
- SP6-010-13 to 15: Separation pressure, user 1 paper
- SP6-010-16 to 18: Separation pressure, user 2 paper

***Other Factors affected by the selected Paper Type***

The paper type selected for a job affects the paper delivery wing position, whether the paper clamber on the pressure cylinder is used or not, and the separation pad type.

- SP6-011: Separation pad type for standard, special, thick, user 1, and user 2 type paper
- SP6-012: Paper clamp enable/disable for standard, special, thick, user 1, and user 2 type paper
- SP6-013: Paper delivery wing position for standard, special, thick, user 1, and user 2 type paper

***Default Settings***

The following table shows the default settings for each paper type. For the pressure, the higher the SP mode value, the higher the pressure.

For details about the paper clamber, see 'Pressure Cylinder'. For details about the wing guides, see 'Paper Delivery'.

Paper Type	Feed pressure			Separation pressure			Wing Guides	Paper Clamp
	Std.	Freq.	V. Freq.	Std.	Freq.	V. Freq.		
Standard	3	5	6	3	4	6	Up	Yes
Thick	3	5	6	2	4	6	Down	Yes
Special	1	3	5	1	3	5	Down	Yes
User 1 or 2: Standard, no feed	5	6	6	2	4	6	Up	Yes
User 1 or 2: Standard, double feed	2	4	6	4	5	6	Up	Yes
User 1 or 2: Thick, no feed	5	6	6	1	3	5	Down	Yes
User 1 or 2: Thick, double feed	3	5	6	3	5	6	Down	Yes
User 1 or 2: Thick, medium	3	4	5	3	5	6	Down	Yes

***Separation Pad Type for Each Paper Type***

The paper type selected for a job also affects the separation pad type.

- SP6-011-1: Separation pad type for standard paper.
- SP6-011-2: Separation pad type for thick paper.
- SP6-011-4: Separation pad type for special paper.
- SP6-001-5: Separation pad type for 'user 1' paper type.
- SP6-011-6: Separation pad type for 'user 2' paper type.

**PAPER REGISTRATION MECHANISM**

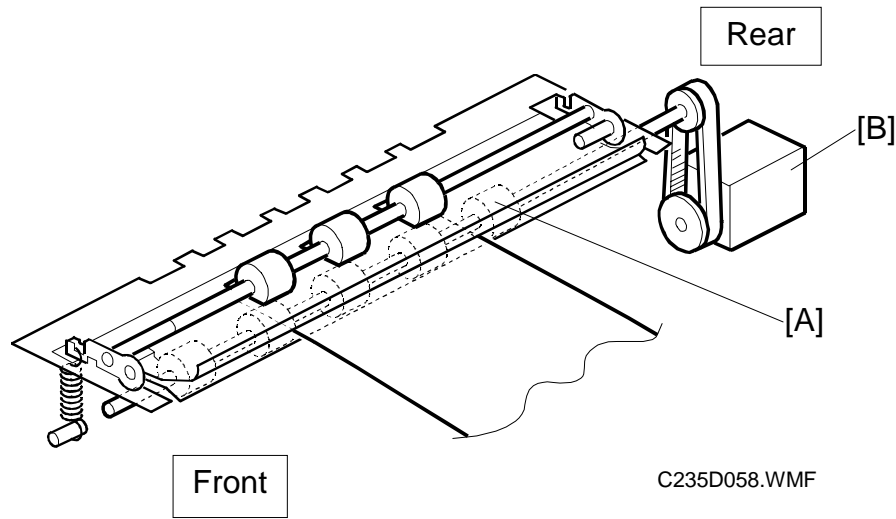

Detailed Descriptions

**Registration Roller Drive**

The lower registration roller [A] is driven by a stepper motor [B] (the registration motor).

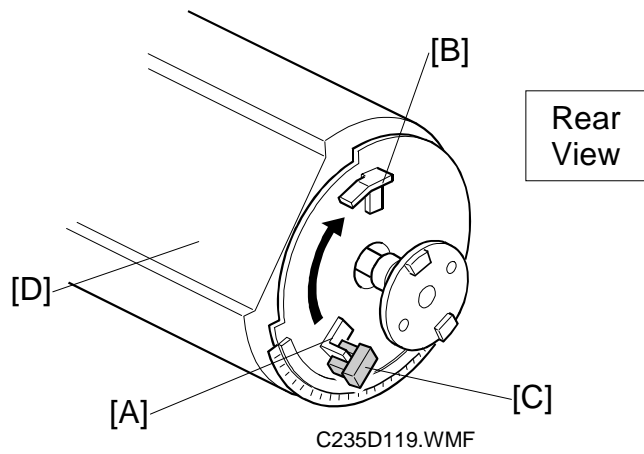

Paper feed timing must be synchronized with the pressure cylinder rotation, so the registration motor on timing is maintained by the feed start sensor [C].

A short time after the pressure cylinder [D] starts rotating, the actuator [A] on the rear of the pressure cylinder activates the sensor. A pre-determined duration later (see Note 1 below), the registration motor starts turning to feed paper to the drum and pressure cylinder. After the printing paper is caught between the drum and the pressure cylinder, the registration motor stops.

- NOTE:** 1) The registration motor rotation speed is constant. However, when the operator selects a higher or lower printing speed (to change the copy image density), the drum and pressure cylinder rotation speed changes. The registration motor must feed the paper at the correct time for the leading edge to be caught by the paper clamber on the pressure cylinder. Therefore, the registration motor start timing after the paper feed start sensor is activated depends on the printing speed selected.
- 2) There are two actuators: [A] and [B]. The actuator [B] is used to maintain the paper feed motor start timing. (This was mentioned earlier, in 'Paper Feed Mechanism'.)

### *Image Up/Down Shift Mode*

In addition, the registration motor start timing is changed by pressing the image position keys on the operation panel (this is the image up/down shifting mode). If the paper feed timing is delayed, the image is shifted forward.

**NOTE:** The leading edge of the paper must be precisely caught by the paper clamber on the pressure cylinder after leaving the registration rollers. When the image up/down shifting mode is used, the position of the pressure cylinder changes through the image up/down mechanism, so the registration motor start timing must change. (The drum stays at home position.) For details of the mechanism, refer to "2.10 Image Up/Down Shifting" section.

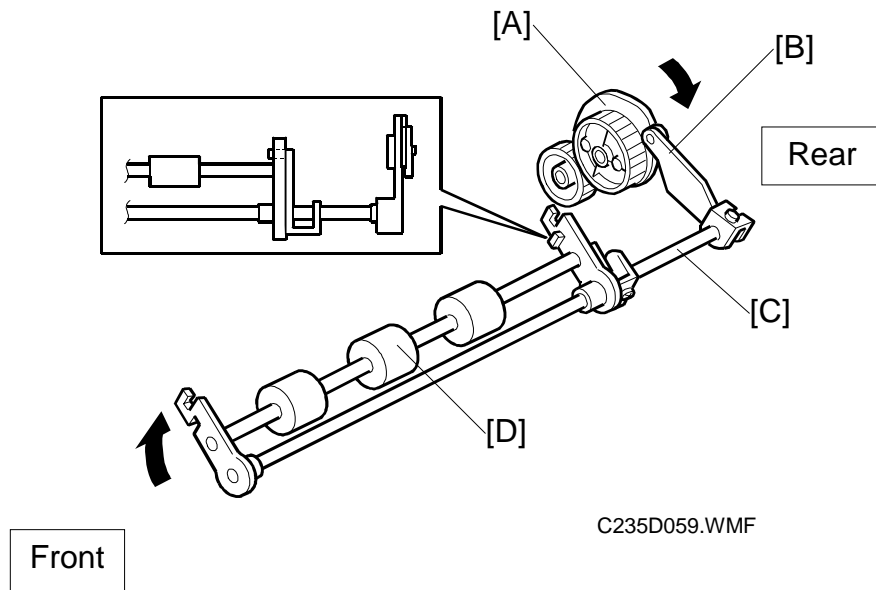
**Registration Roller Up/Down Mechanism**

Detailed Descriptions

After the paper is caught between the drum and the pressure cylinder, the upper registration roller is released from the lower registration roller. This is to prevent interference from the registration rollers while the paper is being fed by the drum and the pressure cylinder.

When the high point of the cam [A] on the drum drive gear reaches the cam follower [B] (a bearing), the shaft [C] rotates clockwise (as seen from the operation side) to release the upper registration roller [D] from the lower registration roller.

## 2.6.4 PAPER FEED CONTROL MECHANISM

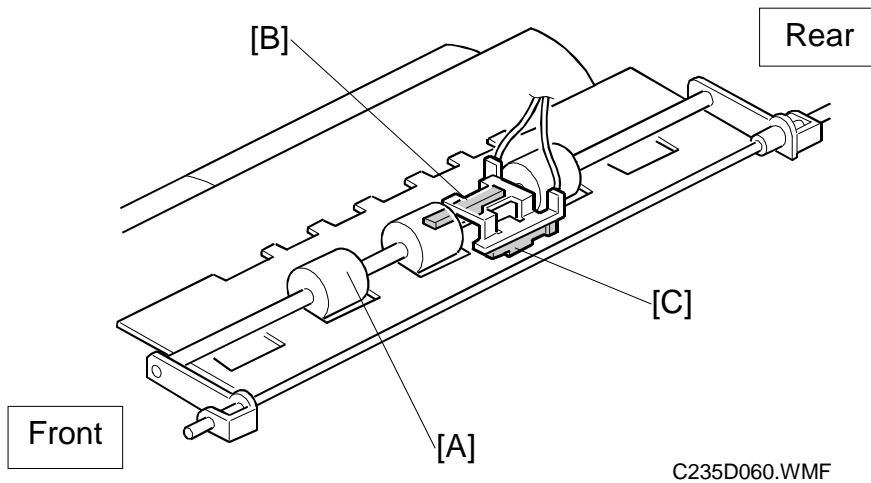

The paper feed timing around the registration roller [A] is monitored by two different photo-sensors. The first is the paper registration sensor [C], which is located before the registration roller. The second sensor is the paper feed timing sensor [B], which is located after the registration roller.

The paper registration sensor [C] detects the paper arriving at the registration roller. The paper feed motor start timing is determined by this sensor. When the paper comes into contact with the rollers, the motor remains stopped to create a buckle in the paper to obtain precise paper registration and to prevent paper skew. The motor starts turning a pre-determined period after the sensor is activated by the paper. The sensor is also used to detect jams.

The paper feed timing sensor [B] is also used to detect paper jams. It is also used to compensate for delays in paper feed caused by slippage at the registration roller, as described below.

The CPU monitors the paper feed timing sensor after the registration motor starts turning. If the sensor turns on late, the CPU determines that there has been slippage at the registration roller. Depending on the size of the delay, the registration motor speeds up to recover the delay.

### 2.6.5 PAPER TABLE ANGLE ADJUSTMENT MECHANISM

There are two paper table open positions: level, and 15 degrees upward slant. Normally the paper table is set at the level position.

The 15 degrees upward slant position is used to feed special types of paper, such as envelopes, which are difficult to feed at the level position. In the slanted position, the tray capacity is reduced.

As the paper table [A] is lowered from the closed position, the pin on the lever [C] engages the cutout in the lock bracket [B]. Then, the paper table stops at the level position.

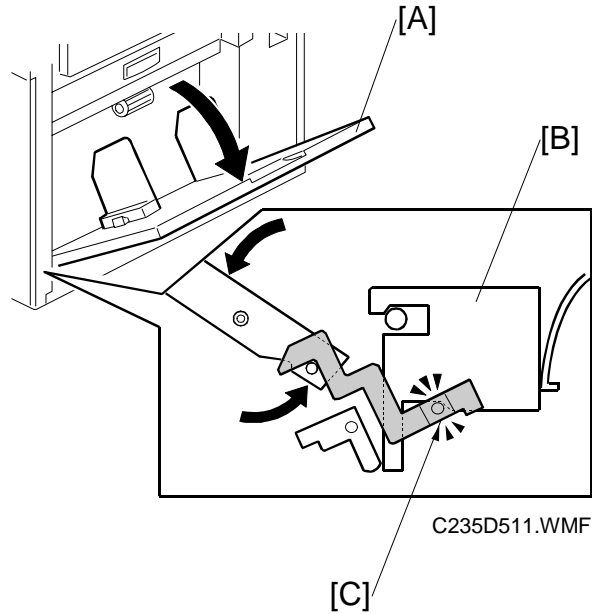

Detailed Descriptions

When the paper table is slightly raised from the level position, the spring plate [D] pushes the lock bracket [B], and the pin on the lever [C] disengages. This stops the table at the 15 degrees upward slant position.

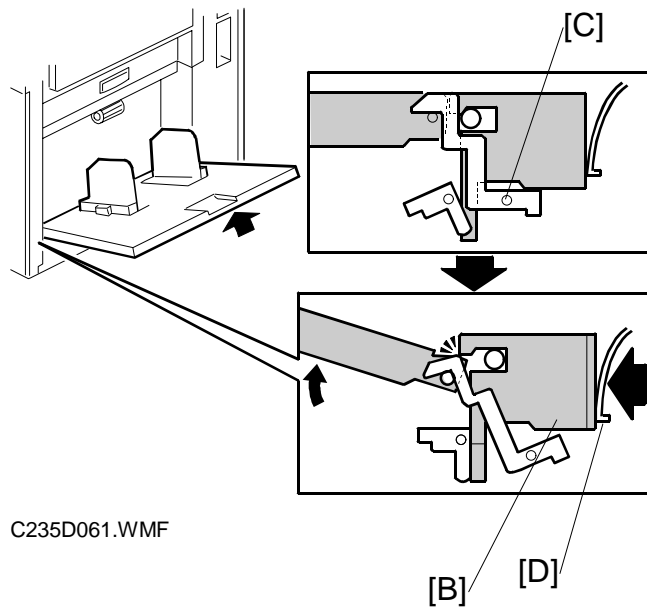

### 2.6.6 PAPER TABLE OPEN DETECTION

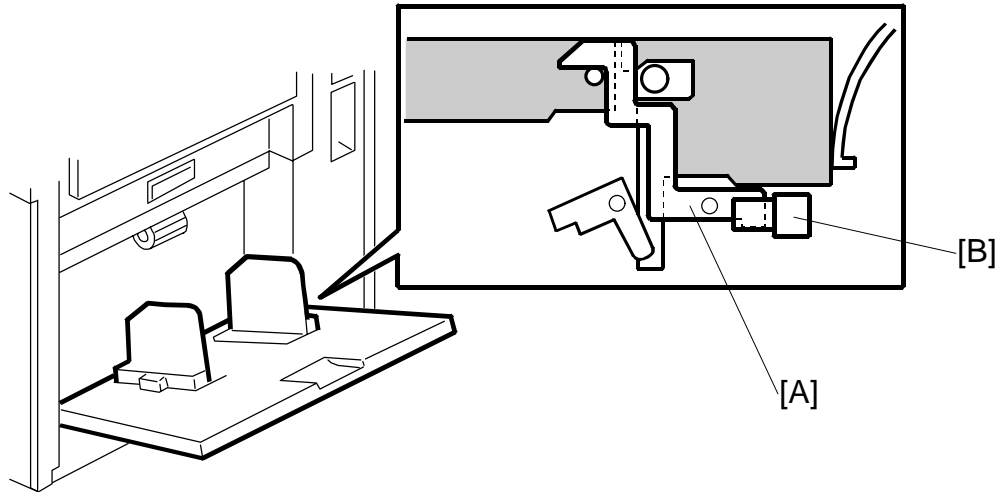

C235D610.WMF

When the paper table is open, the lever [A] activates the paper table set sensor [B]. If the paper table remains closed and the sensor is not activated, guidance will be displayed on the operation panel.



## 2.6.7 PAPER TABLE UP/DOWN MECHANISM

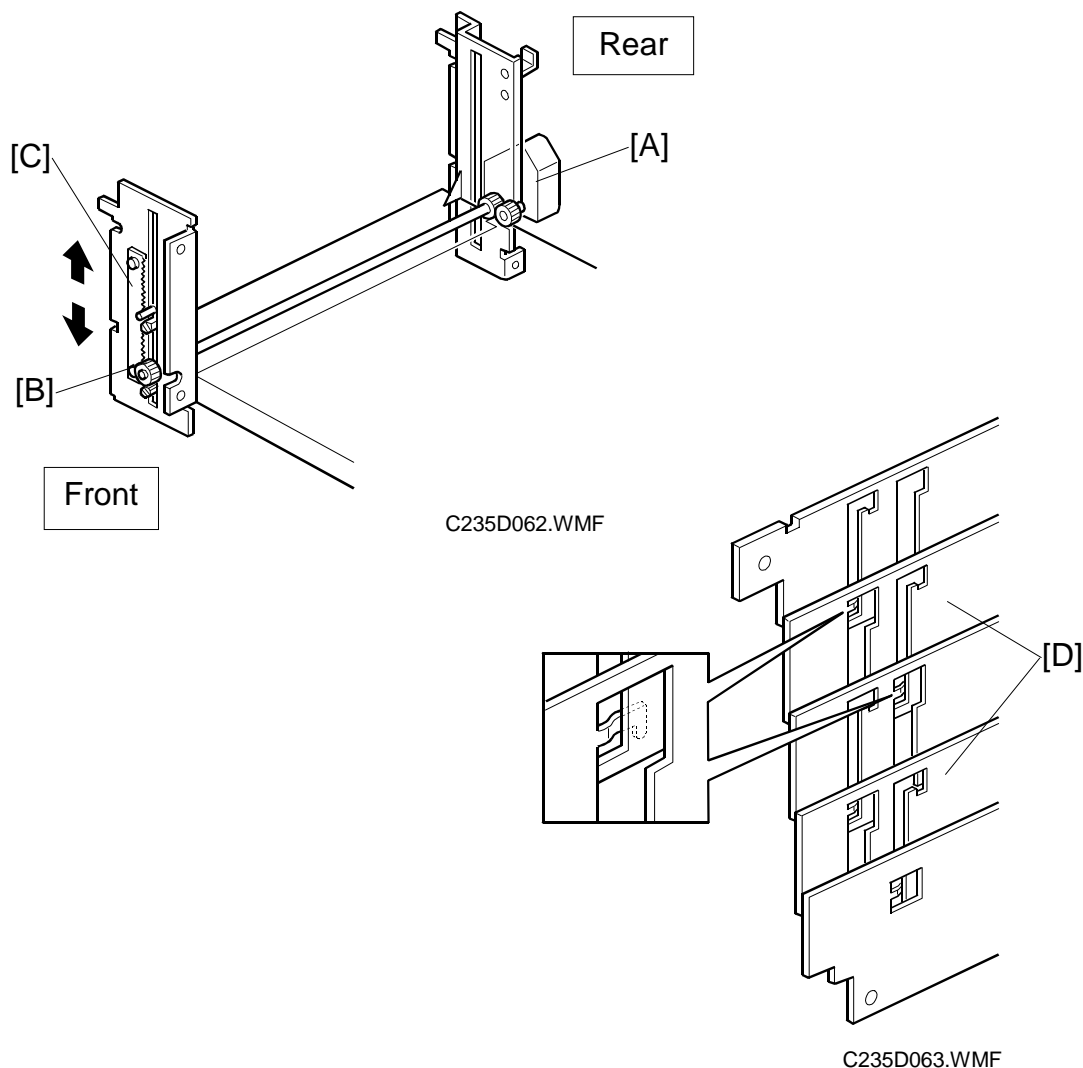

### ***Paper Table Drive Mechanism***

An independent dc motor, the paper table motor [A], drives the paper table. When the motor turns, the pinion [B] turns along the rack [C], moving the paper table up or down.

To reduce noise, there is a shutter cover below the table, which is a combination of 5 plates. The shutter closes the opening beneath the paper table when the table is lifted up.

**NOTE:** Although each plate of the shutter looks similar, only the second and fourth plates [D] from the top are the same in shape. The other plates are all different from each other. Be sure to re-assemble in the correct sequence.

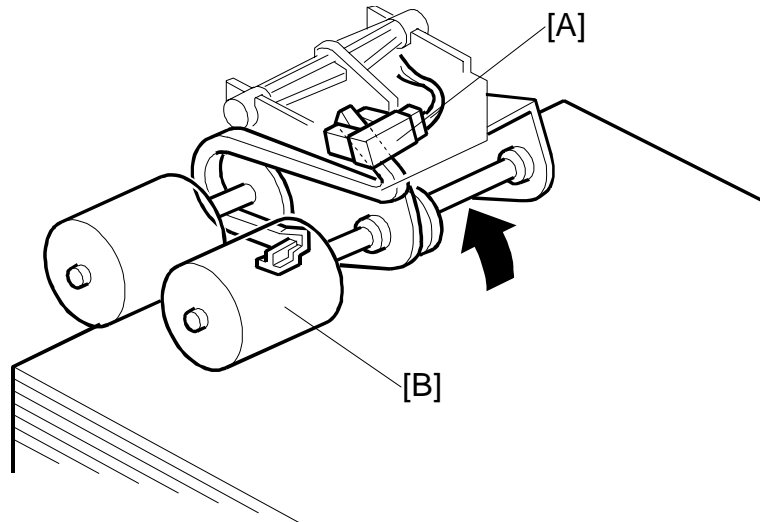
**Table Upper/Lower Limit Detection and Paper Height Control**

C235D066.WMF

When the paper table moves up, the top of the paper stack contacts the pick-up roller [B], lifting it up. Then, when the paper height sensor [A] is actuated, the paper table stops.

During a printing run, sheets are fed from the stack, and the pick-up roller lowers. When the paper height sensor is de-actuated, the paper table motor starts turning and lifts the paper table until the sensor is actuated again. In this way, the top of the paper stack remains at the same position during printing.

When the tray lowers, the lower limit position is detected by the paper table lower limit sensor (not shown), which is located beside the paper table motor.

## 2.6.8 PAPER SIDE FENCE MECHANISM

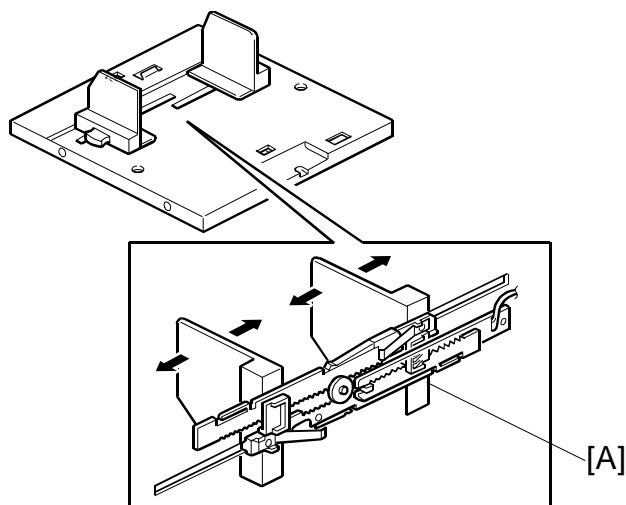

C235D064.WMF

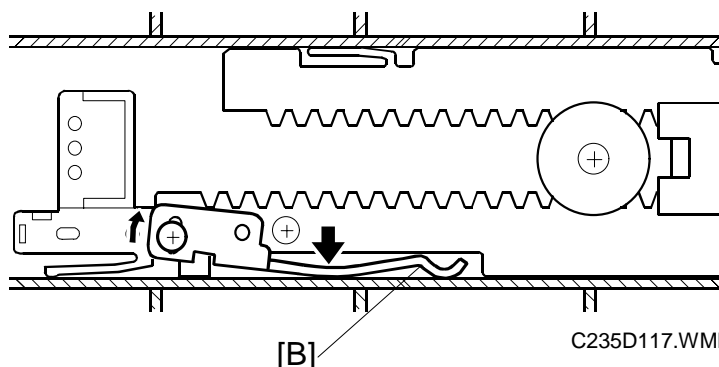

C235D117.WMF

The left and right side fences move together due to a rack and pinion mechanism.

The actuator plate [A] is attached to the rack. This actuates the paper width detection board, to detect the position of the side fences (see Paper Size and Paper End Detection).

The side plate friction pads on the front and rear paper side fences prevent multiple feed. These are especially useful when thin paper is used.

There are two spring plates [B] applying pressure against the racks (one spring plate each for the right and left racks). Normally, there is no pressure applied to the racks. However, during long copy runs, the side plates may move away from the sides of the stack. By adjusting the position of the spring plates, the side fence pressure can be increased.

### 2.6.9 PAPER SIZE AND PAPER END DETECTIONS

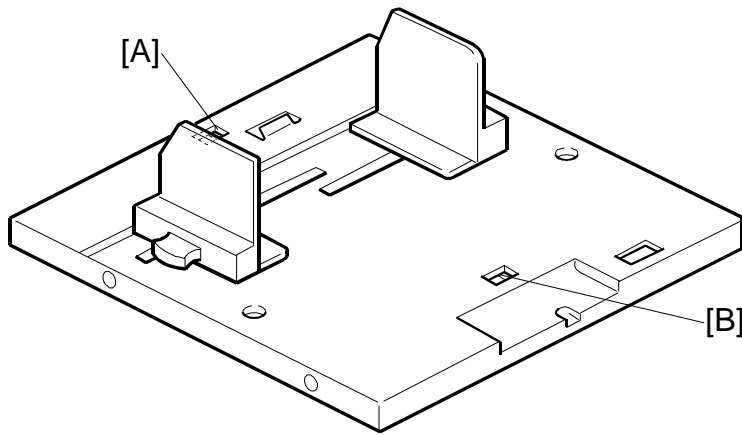

C235D040.WMF

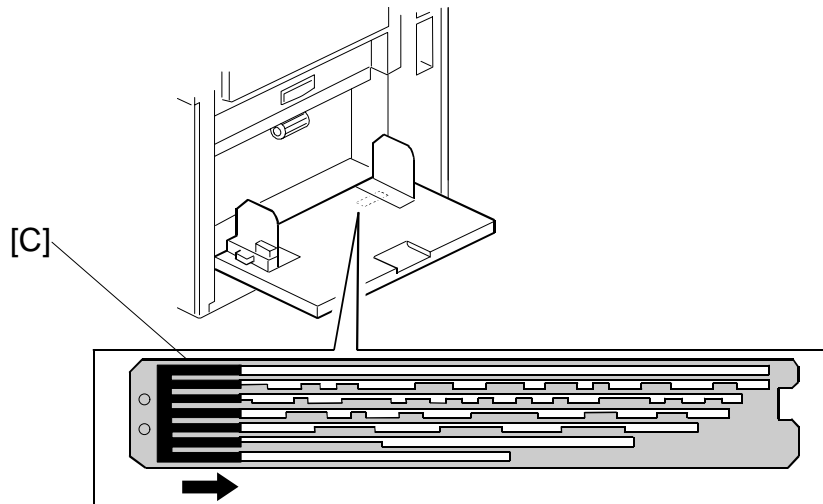

C235D065.WMF

When paper is placed on the paper table, the paper end sensor [A], which is a reflective photosensor, is activated.

If B4 sized (or 8 1/2" x 14") paper or larger is set on the paper table, the paper length sensor [B] is activated.

The actuator plate [C] is attached to the rack for the paper side fences. The paper width detection board detects the position of the side fences. The paper size data is sent to the CPU in combination with the status of the paper length sensor.

## 2.6.10 PAPER SIDE FENCE LOCK MECHANISM

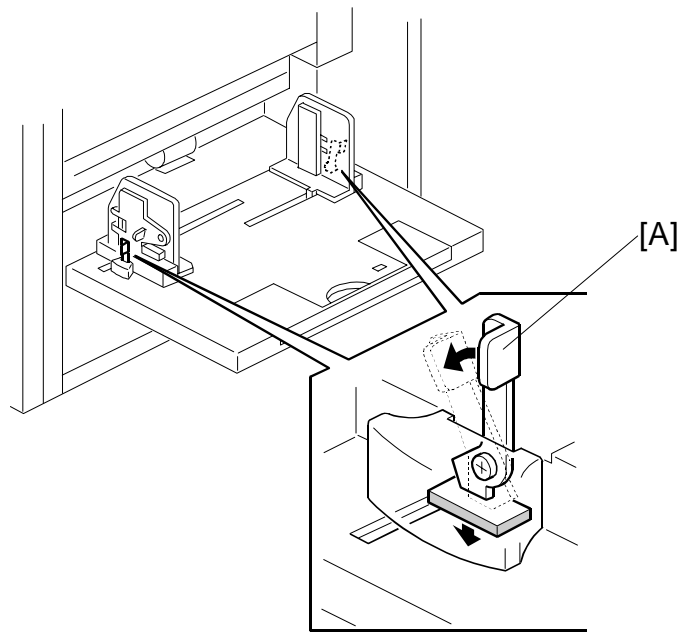

C235D007.WMF

Detailed  
Descriptions

To prevent the side fences from moving during printing, the user can push down the levers [A].

## 2.7 PRINTING AND PRESSURE CYLINDER

### 2.7.1 OVERVIEW

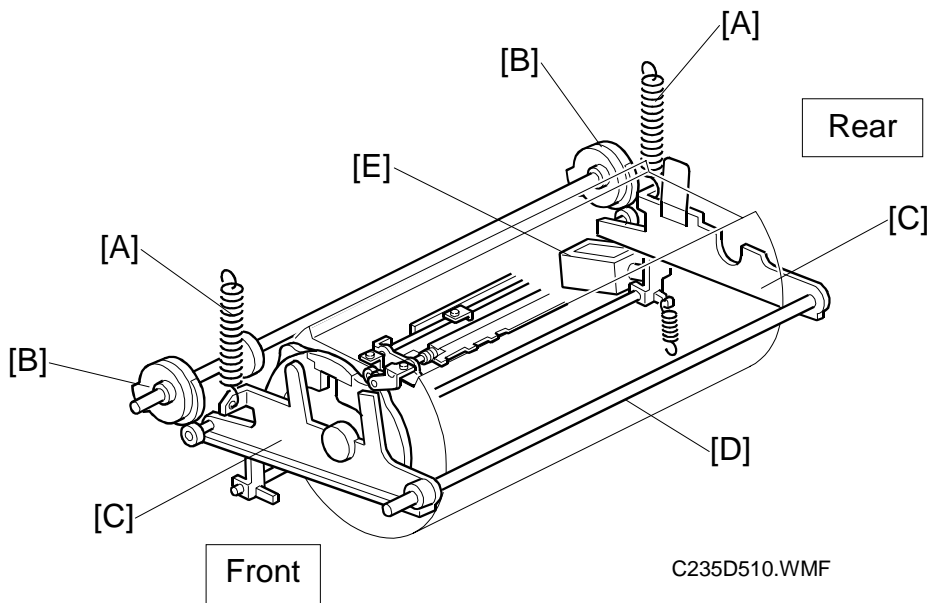

This model uses a pressure cylinder, instead of a press roller.

Two printing pressure springs [A] (one each at front and rear) pull the pressure cylinder up against the drum through the front and rear printing pressure arms [C]. (The arms rotate around the shaft [D].) Normally, the arms are engaged and the printing pressure is not applied. When the paper reaches the image transfer area, the arms are released by the printing pressure release solenoid [E].

The printing pressure cams [B] control the printing pressure application area to avoid the master clamber on the drum.

In this model, there are two possible master sizes. Printing on a large master (A3 sized cut) or small master (A4 sideways sized cut) is selected automatically (only if the optional ADF is used). The printing pressure cams include two shapes, one for A3 printing and one for A4 printing, so that the machine can switch to the appropriate printing area.

The paper clamber catches the leading edge of the paper after it has passed the registration roller section.

**NOTE:** The paper is clamped in all paper type.

If the paper is still wrapped around the pressure cylinder after it has passed the image transfer area, the lower wrapping jam sensor detects it. (The upper wrapping jam, which is paper wrapping around the drum, is detected by the paper exit sensor in the paper delivery unit.)

## 2.7.2 PAPER CLAMPING

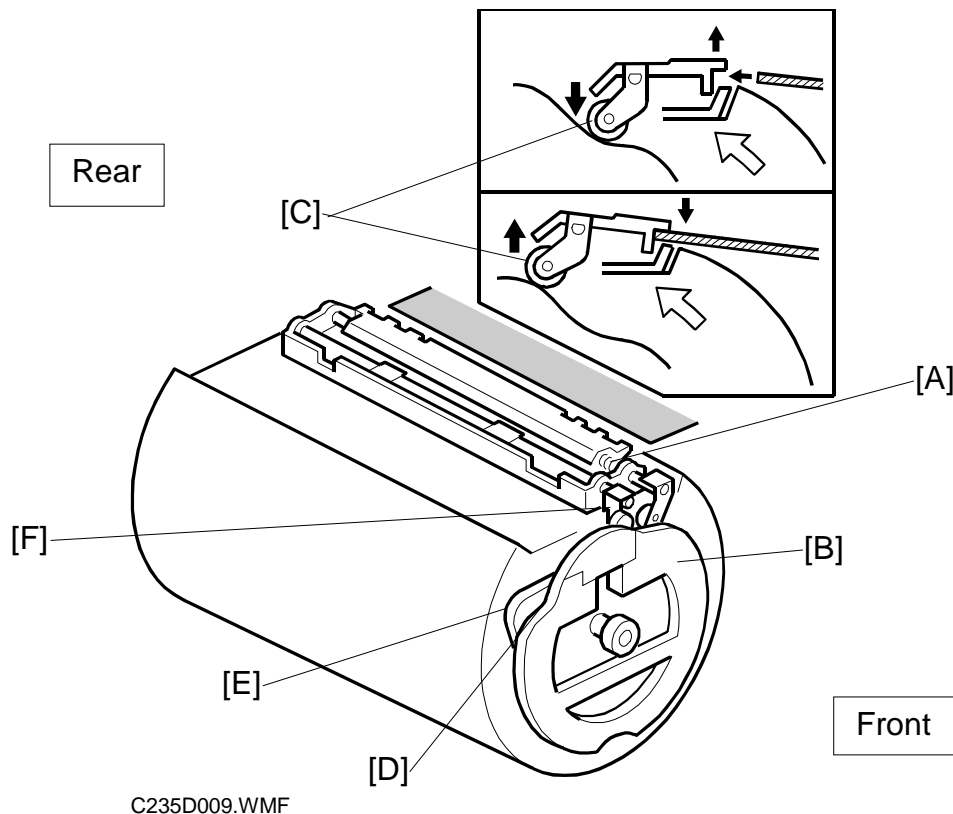

### ***Clamping the Paper***

The paper clamber catches the leading edge of the paper after it has passed the registration roller.

Normally, the paper clamber is held open by spring [A]. At the same time as the leading edge of the paper enters the clamber, the high point of the cam [B] reaches the bearing [C] on the lever at the front end of the paper clamber, and the clamber closes.

Shortly afterwards, the bearing [C] reaches the low point [D], and the clamber opens, to release the paper (the paper is now held between the pressure cylinder and the drum, so the clamber is no longer needed). At about the same time, high point [E] on the cam pushes up another bearing (attached to lever [F]), and this forces some pawls towards the paper to push it out of the clamber. This mechanism is shown on the next page.

In the C235/C233 model, when thick paper mode is selected on the operation panel, the paper is not clamped. However, the C235 model can clamp thick paper.

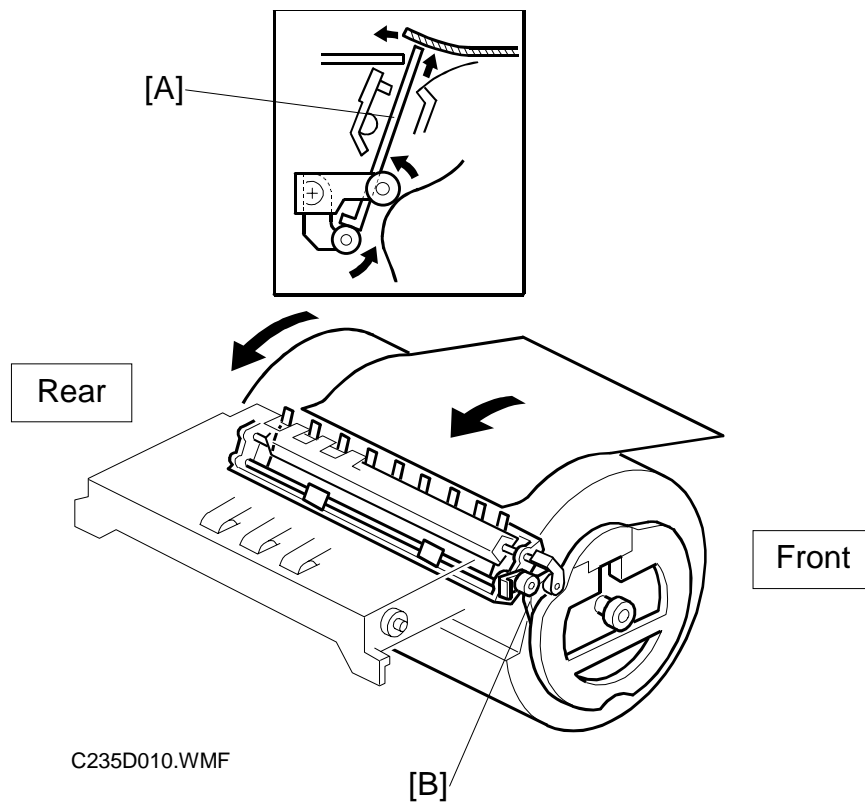

***Releasing the Paper***

The paper is released shortly after the leading edge passes through the nip between the drum and pressure cylinder where the image is transferred to the paper, and it is fed towards the paper delivery unit.

As the pressure cylinder rotates, the high point of the inner cam [B] reaches the bearing at the front end of the clamber. The clamber is again opened and the paper is released.

The opening angle of the clamber for releasing is larger than for clamping, and this causes the paper release pawls [A] to rise to push the clamped edge of the paper, which helps the release mechanism.



### 2.7.3 PRINTING PRESSURE MECHANISM

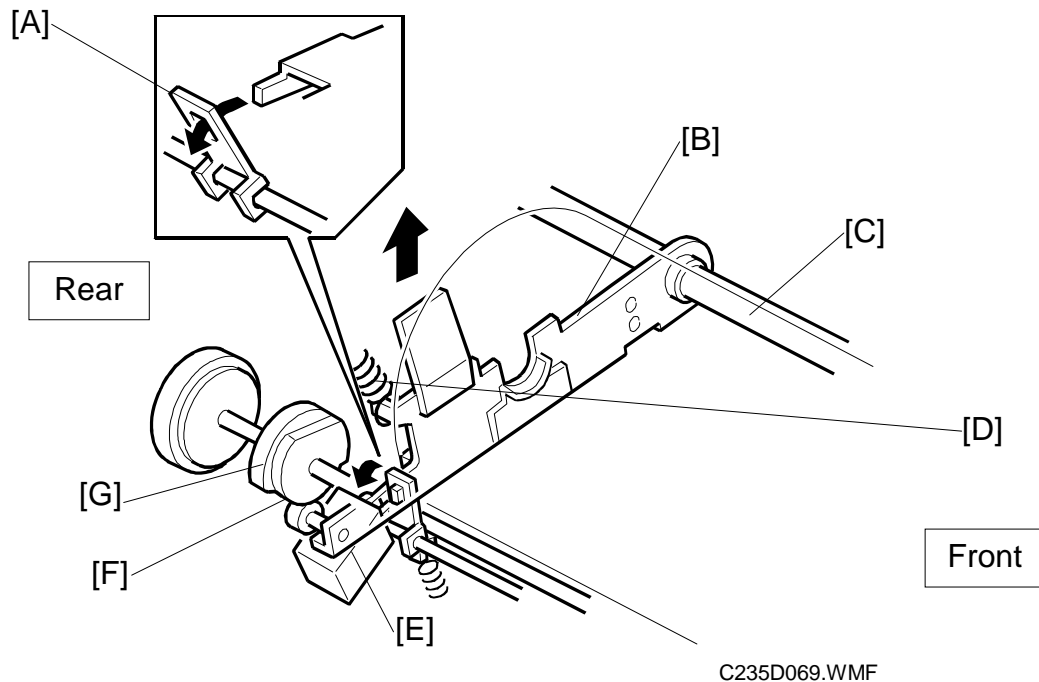

There are two printing pressure springs [D] and two printing pressure arms [B], one each at front and rear. The pressure cylinder rests on the printing pressure arms. Normally, the arms are engaged and the printing pressure is not applied.

The printing pressure cam [G] always rotates because of drive from the main motor. When the high point of the cam reaches the bearing [F] on the printing pressure arm, it pushes down the arm slightly. At this moment, a small gap is created between the hook on the arm and the printing pressure release lever [A]. Then, the printing pressure release solenoid [E] can release the arms. This occurs when the paper reaches the image transfer area.

When the arms are released, the two printing pressure springs pull the pressure cylinder up against the drum through the front and rear printing pressure arms, which turn around the release arm shaft [C].

The printing pressure cam controls the printing pressure application area to prevent printing pressure from being applied to the master clamber area on the drum. After the printing pressure arms are released, the printing pressure is applied while the bearing on the printing pressure arm is riding on the low point of the cam. When it rides on the high point of the cam, the printing pressure is released to avoid the master clamber.

**NOTE:** Do not clean the pressure cylinder surface with alcohol or other strong solvents. Use a cloth dampened with water. Periodic cleaning is required for this part.

## 2.7.4 PRINTING PRESSURE CAM SHIFTING FOR A3/A4 SIZE MASTERS

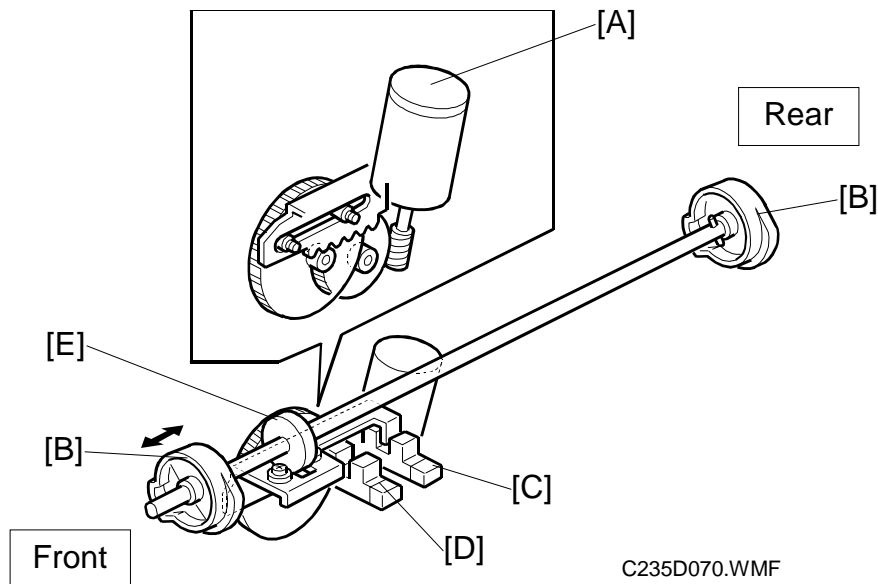

C235D070.WMF

In this model, printing on a large master (A3 sized cut) or a small master (A4 sideways sized cut) is selected automatically (only if the optional ADF is used).

When the CPU detects that A4 sized paper (or 8 1/2" x 11") or smaller has been set in the sideways feed direction on the paper table, and two or more originals have been placed in the ADF, the machine automatically makes the smaller master.

**NOTE:** The master sizes are as follows:

Large Master: 320 x 530 mm (320 x 540 mm for U.S.A. models)

Small Master: 320 x 355 mm

Since the small master does not cover all the printing area of the drum screen, the last original's image is always made on a large master. This is to prevent the drum screen from drying if the next printing job is not done for a long time.

Therefore, a small master is not made when there is only one original in the ADF, even when printing on small paper. (In the Platen mode, the small master is never made because the machine cannot detect the number of originals.)

Based on the master size, the correct printing area is applied automatically. The printing pressure cam [B] includes two shapes (for A3 printing and for A4 sideways printing) in one part.

When switching the printing area, the pressure cam shift motor [A] turns. The switching plate [E] moves the cam shaft from side to side through some gears, which moves the printing pressure cam at each end of the shaft from side to side. The rack moves until either the A4 cam sensor [D] or A3 cam sensor [C] is activated.

## 2.7.5 PAPER FEED CONTROL MECHANISM

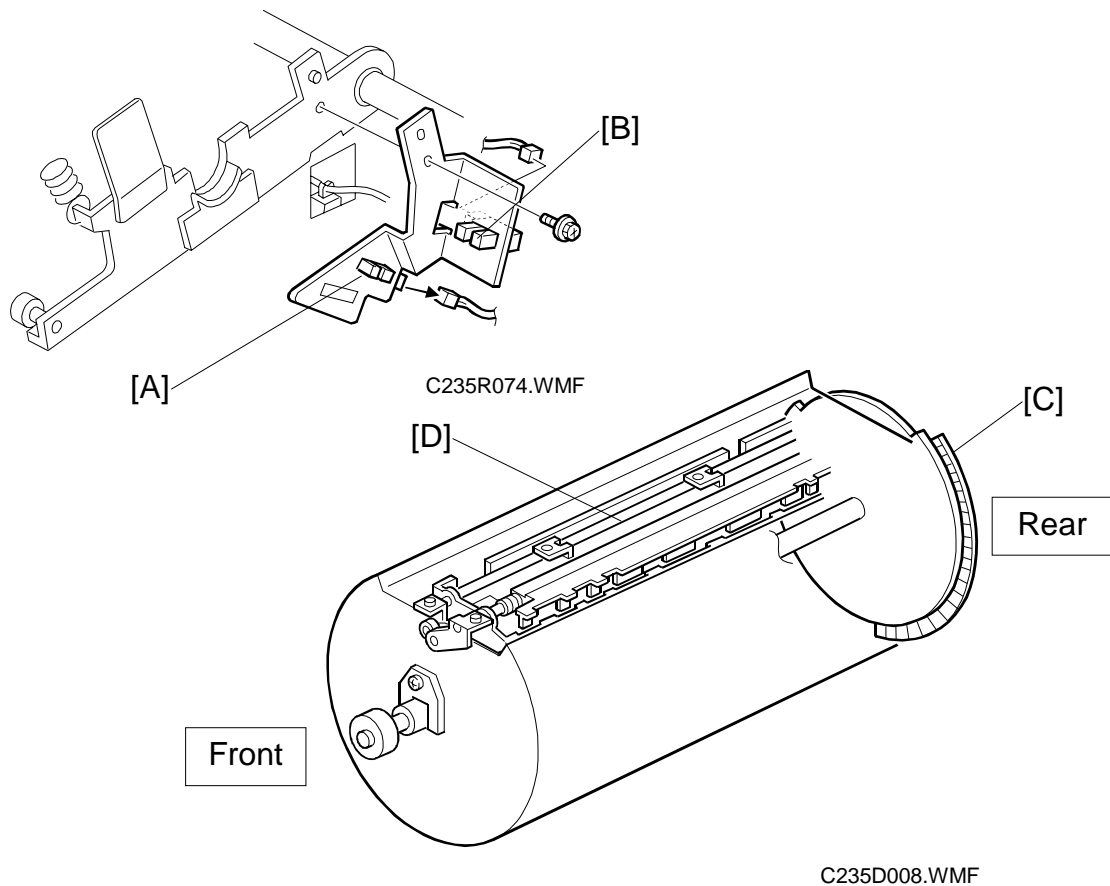

### ***Paper Feed Start Timing Detection***

There are two actuators on the rear flange of the pressure cylinder. The two actuators activate the paper feed start sensor [A], to determine the start timing of the paper feed motor and the registration motor. (For details, refer to the Paper Feed section – Paper Feed Mechanism, and Paper Registration Mechanism.)

### ***Detection and Feedback of Pressure Cylinder Rotation Fluctuation***

Since the pressure cylinder does not have a perfectly circular cross-section, the rotation speed tends to fluctuate.

The feed encoder [B], which is a photointerrupter, is activated by the encoder plate [C] at the rear of the pressure cylinder, generating a pulse signal. The CPU monitors this signal to detect fluctuations in the pressure cylinder rotation.

Depending on the detected fluctuation, the registration motor start timing is adjusted so that the leading edge of the paper is precisely caught by the paper clamper [D] on the pressure cylinder.

### 2.7.6 PRESSURE CYLINDER DRIVE MECHANISM

#### Overview

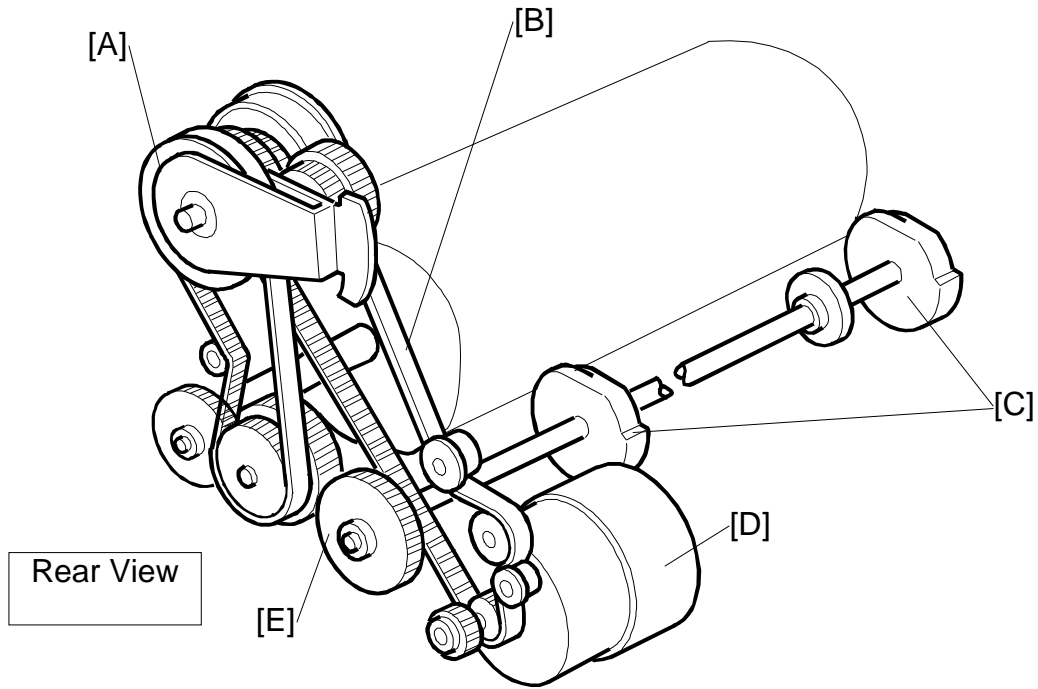

C235D072.WMF

The main motor [D] rotates the pressure cylinder through the main drive timing belt [B], image up/down shift mechanism [A], timing belt [F], and gears, as shown above. The gear [E] is also driven by the main motor, and it rotates the printing pressure cams [C].

### ***Pressure Cylinder HP Return Mechanism (Manual Pressure Cylinder Rotation)***

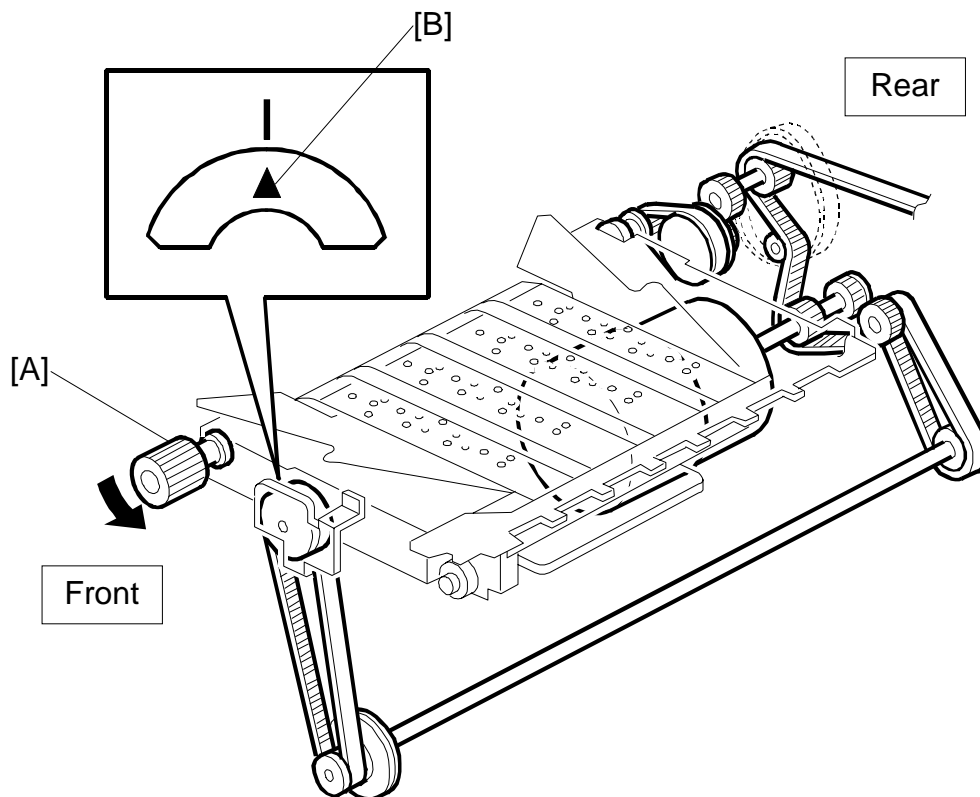

C235D042.WMF

If the operator rotates the pressure cylinder by hand while removing the drum, the main motor drive also turns. It may not be possible to reinstall the drum, because the position of the drum drive gear will have changed.

The knob [A] is used to rotate the main motor drive manually. A small plate covers the knob normally, because it is only for emergency use.

If this happens, the knob can be used to turn the main motor drive. When the arrow [B] on the indicator disk meets the center division, the drive is at home position. The drum drive gear is also at home position, and the drum can be reset.

### 2.7.7 DRUM HOME POSITION DETECTION

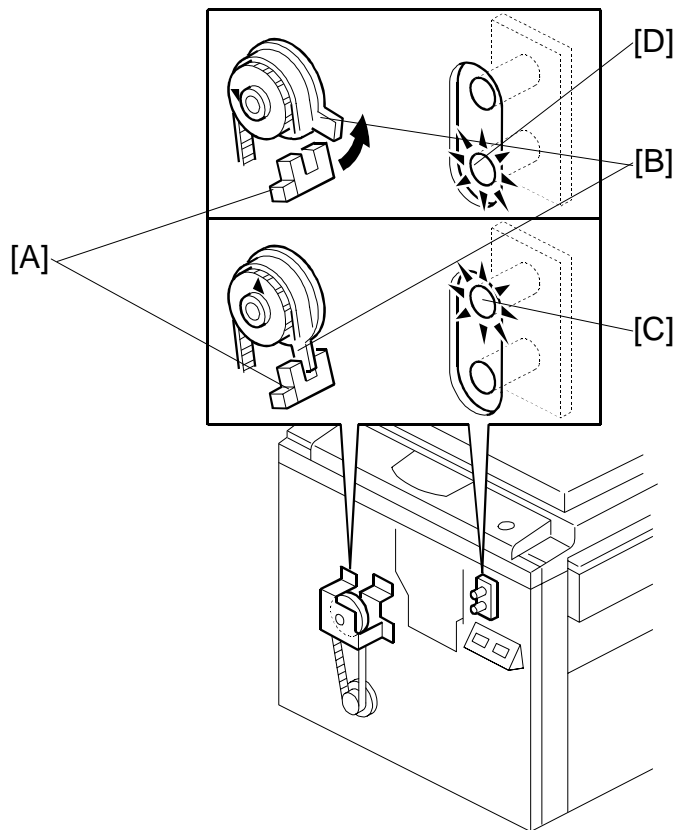

C235D720.WMF

LEDs are added to inform the operator when the drum is at the exact home position and can be pulled out. The drum home position is monitored by the drum home position sensor [A], which is newly added for the actuator disk [B] on the pressure cylinder.

Green LED [C] turns on when the drum is at the home position.

Red LED [D] warns that the drum is not at the home position.

**NOTE:** If the red LED lights when the machine is in standby mode, the drum is not at the home position and the front door must be closed to reset the drum position.

## 2.8 PAPER DELIVERY

### 2.8.1 OVERVIEW

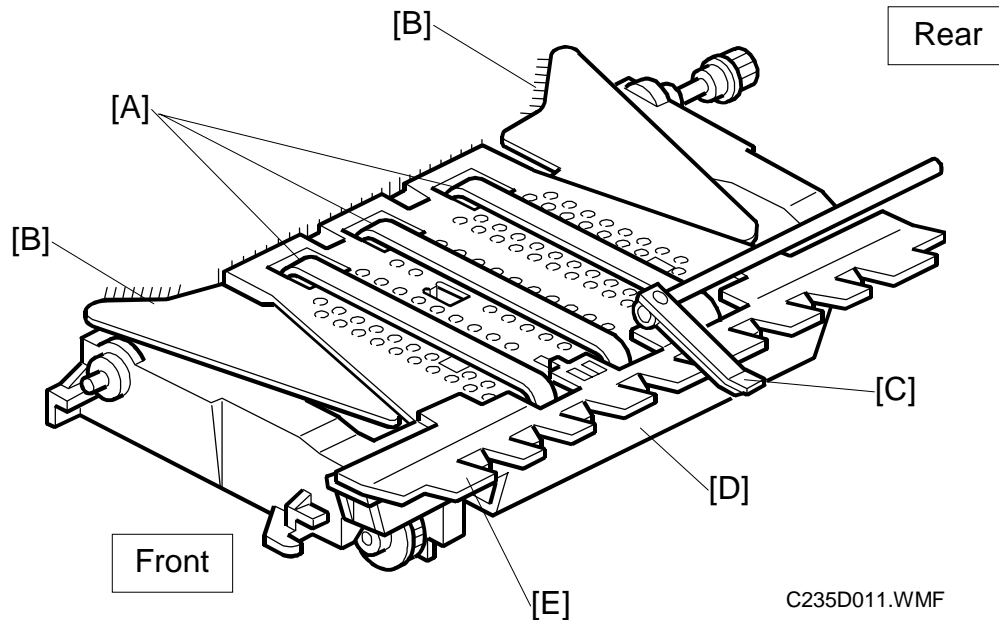

Detailed  
Descriptions

The paper delivery unit consists of three rubber belts [A] and the vacuum fan motor [D]. The rubber belts are driven by the main motor, and they feed the paper, which is held against the belts by suction generated by the vacuum fan motor.

The paper pick-off plate [E] is located close to the pressure cylinder, in order to prevent the paper from being wrapped around the pressure cylinder.

The paper guide wings [B] help to feed out the paper to the delivery table. A dc motor (the wing guide motor) changes the angle of the wings automatically. There are two settings, and the setting used depends on the paper type selected at the operation panel.

The exit sensor (not shown) detects paper misfeeds.

The exit pawl [C] prevents paper from wrapping around the drum. Two air knife fans help to separate the paper from the drum.

### 2.8.2 PAPER SEPARATION FROM THE DRUM

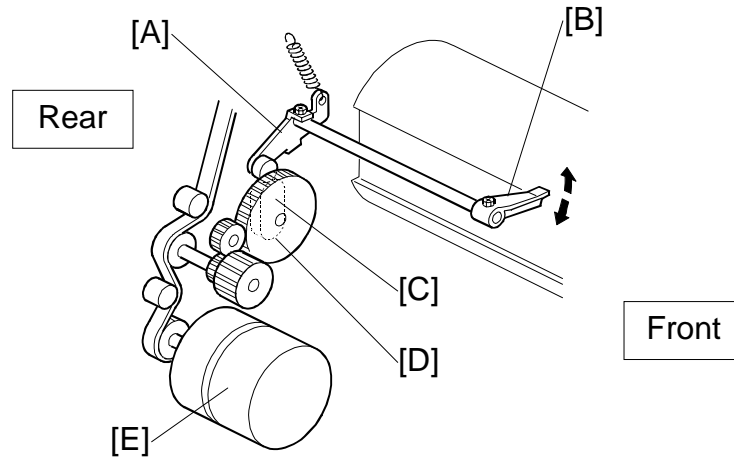

C235D027.WMF

#### ***Exit Pawl Drive Mechanism***

The exit pawl [B] guides the center of the paper. This prevents the paper from wrapping around the drum. As the drum rotates and the master clamber approaches the exit pawl, the exit pawl moves away from the drum.

As the main motor [E] turns, the exit pawl drive gear [D] turns. This gear contains a cam [C]. The cam follower on the exit pawl lever [A] rides on the cam. The exit pawl is connected to the exit pawl lever.

The lever turns clockwise when the cam follower rides on the high point of the cam, and the exit pawl moves away from the drum. This happens when the master clamber on the drum is approaching the exit pawl.

When the master clamber moves away from the exit pawl, the cam follower is now riding along the low point of the cam. Therefore, the exit pawl moves nearer the drum surface due to tension from a spring.

When printing pressure is not applied, the exit pawl is held away from the drum.

#### ***Air Knife Mechanism***

There are two air knife fans [F] above the paper delivery unit. These fans blow air against the leading edge of the paper that is just fed from the drum. This helps to separate the paper from the drum.

The air knife fans for the C235 model are more powerful than the ones for the C235 model.

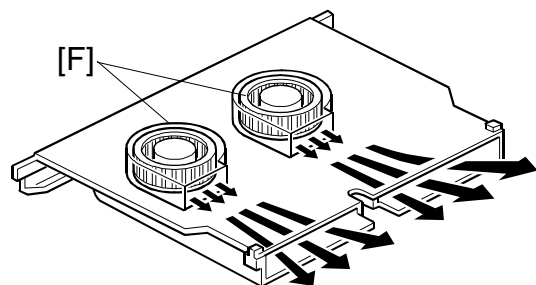

C235D508.WMF



### 2.8.3 PAPER DELIVERY WING MECHANISM

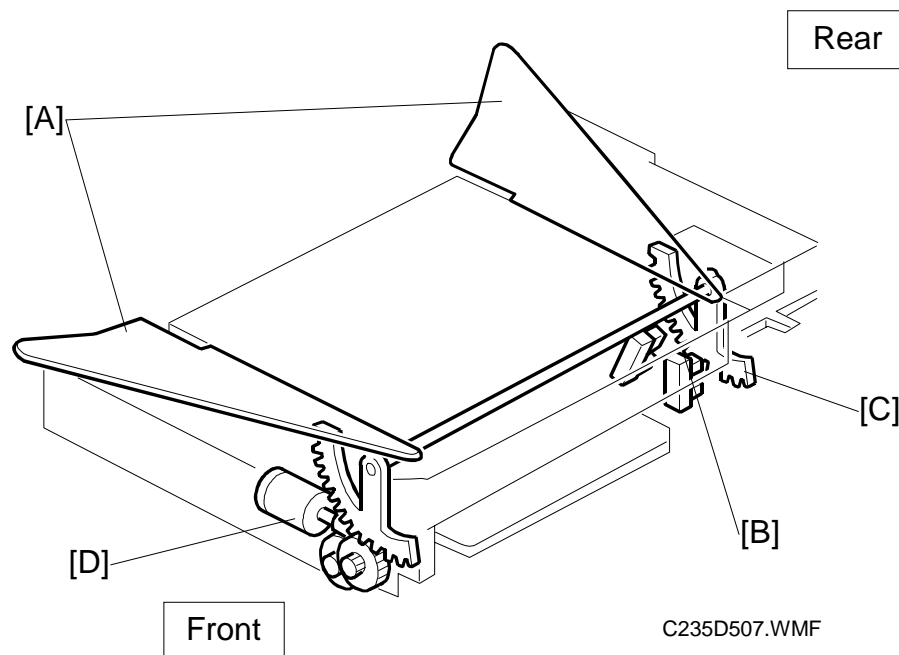

The paper guide wings [A] lift the side of the paper as it leaves the delivery unit.

This stiffens the paper so that the leading edge of the paper will not sag and brush against the sheets on the delivery table. This prevents the ink on freshly printed sheets from being smeared.

The angle of the paper wing guides can be changed automatically by the wing guide motor [D], depending on the paper type selected by the operator at the operation panel. When the paper type is changed, the motor automatically changes the angle of the wing guides.

**NOTE:** The paper types that can be selected are standard, thick, and special. Two additional settings for paper types can be customized as user 1 and user 2. The angle of the paper guide wings for each paper type can be adjusted with SP mode (SP6-013). In addition, the angle can be fixed for all paper types at the upper or lower position with User Tools 4-15, to override the SP6-013 setting. (Refer to the User Tools table in the Service Tables section.)

The wing guide motor [D] moves the paper wing guides up or down through some gears. The wing lower position sensor [C] and wing upper position sensor [B] detect the high and low angle positions of the paper wing guides.

## 2.8.4 PAPER DELIVERY TABLE MECHANISM

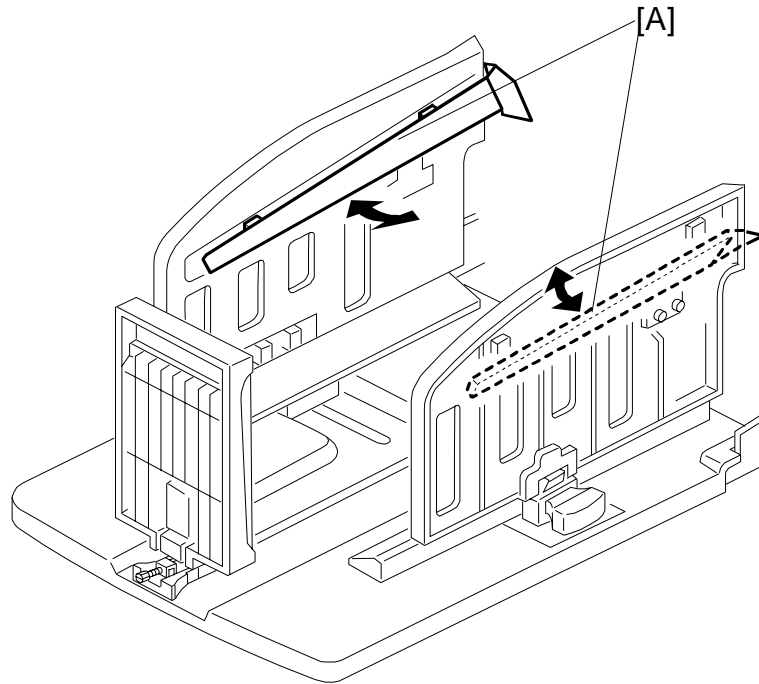

C235D013.WMF

The paper delivery table consists of the rear side fence, front side fence, and end fence. The angle of the small paper guide [A] on each side fence can be changed by pulling the small paper guide.

The small guides help to stack the paper more evenly on the table. Both edges of the paper are guided by the guides as the copy is fed out. Then, the paper is rapidly fed out against the end plate for stacking.

### 2.8.5 PAPER DELIVERY JAM SENSORS

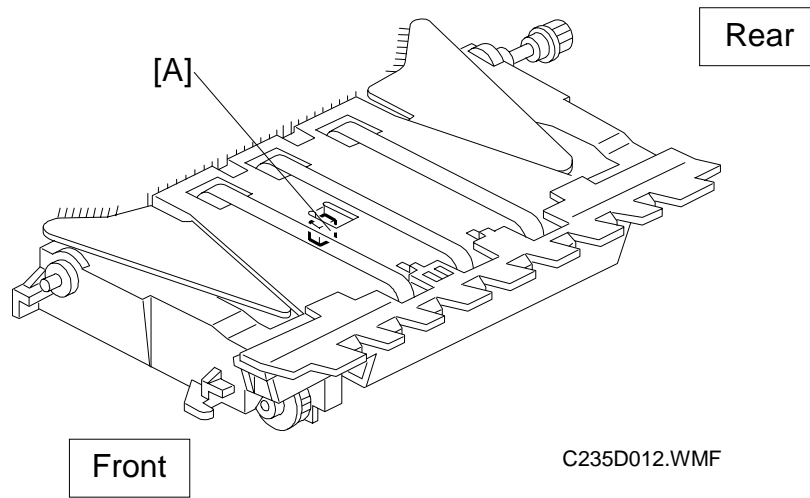

Detailed  
Descriptions

#### ***Paper Delivery Jam***

The exit sensor [A] detects paper jams.

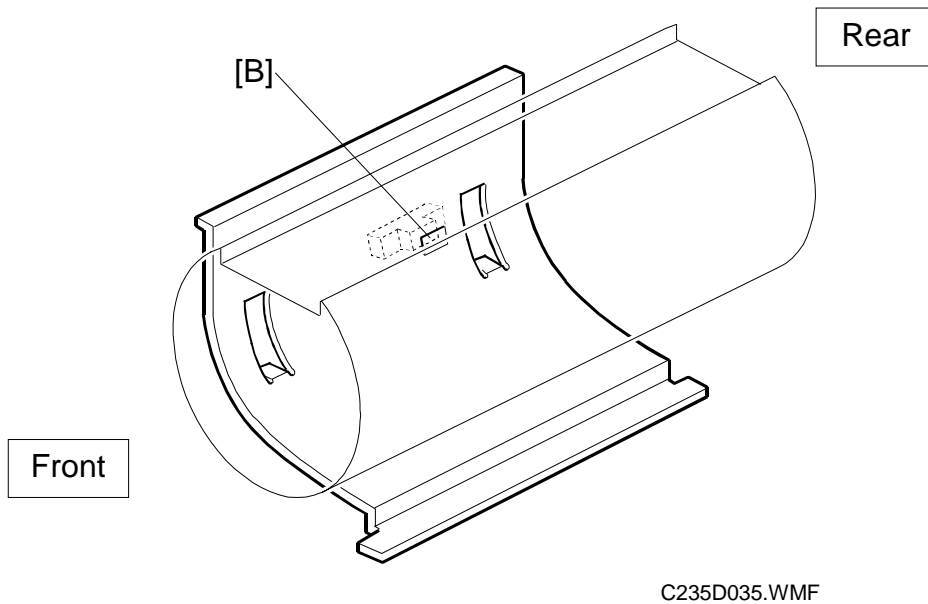

#### ***Paper Lower Wrapping***

The lower wrapping jam sensor [B] detects when paper is wrapped around the pressure cylinder.

## 2.8.6 PAPER DELIVERY UNIT DRIVE MECHANISM

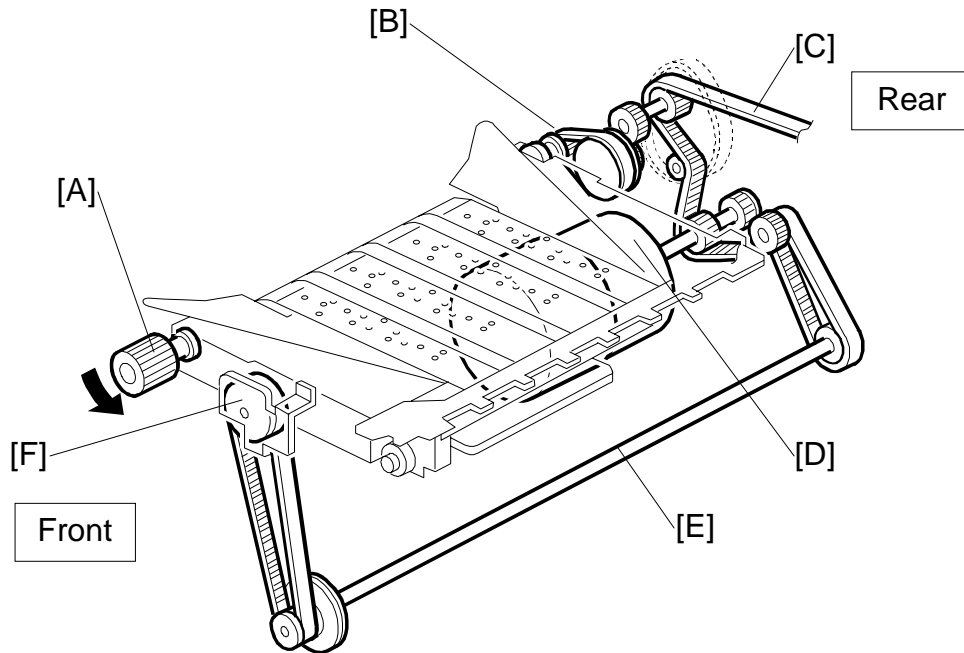

C235D504.WMF

The paper delivery unit is driven by the main motor. As the main motor [D] turns, the main drive timing belt [C] turns. Drive is transmitted to the pulley [B] at the end of the rubber belt drive roller shaft, through the gears and the timing belt.

The knob [A] can be used to rotate the main motor drive manually. A small plate normally covers the knob, and it is not accessible for the operator. It is for emergency use only.

When the knob is turned by hand, it turns the rubber belt drive roller shaft. The rotation is transmitted to the main drive timing belt [C] via the route opposite to the normal main motor drive.

At the same time as the knob is turned, the drive position indicator disk [F] turns through the shaft [E] and two timing belts. The arrow mark on the disk shows the position of the main motor drive.

If the operator rotates the pressure cylinder by hand while removing the drum, the main motor drive also turns. It may not be possible to reinstall the drum, because the position of the drum drive gear will have changed.

If this happens, the knob can be used to turn the main motor drive. When the arrow on the indicator disk meets the center division, the drive is in the home position. The drum drive gear also in the home position, and the drum can be reset.

## 2.8.7 JOB SEPARATION MECHANISM

### Overview

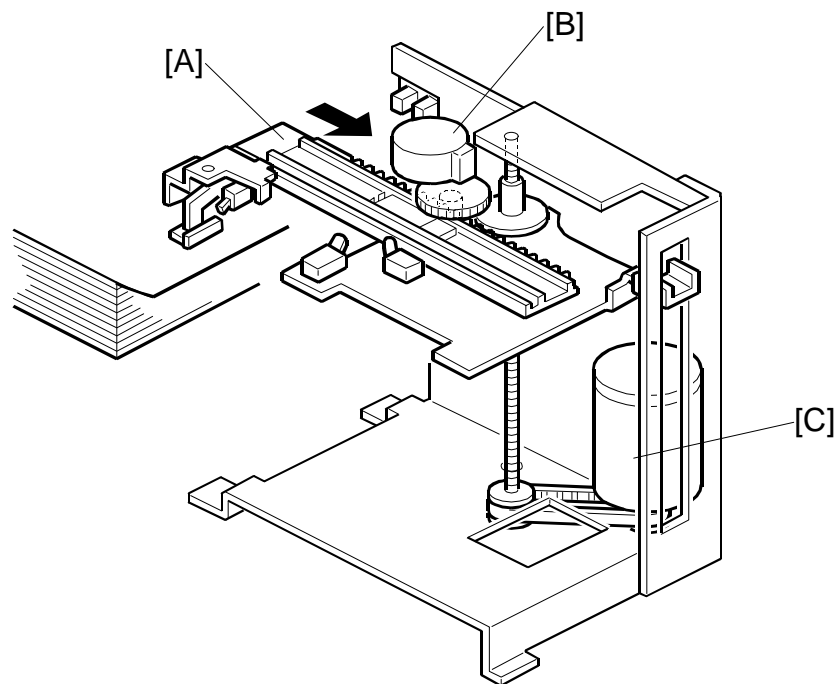

C235D033.WMF

Detailed  
Descriptions

The job separation function can be selected using the Job Separator key on the operation panel. The print on the top of each print set on the paper delivery table is pulled out slightly by the sliding arm [A]. This function is used normally when two or more pages were set in the ADF or when in the Class mode.

When a job (a set of copies of one original) is completed, the job separator motor [B] turns on to move the sliding arm [A] onto the paper stack on the paper delivery table. Then, the slider lift motor [C] lowers the sliding arm.

A high friction material (a type of sandpaper) is attached to the edge of the sliding arm and it touches the top sheet of the paper stack. Then, the job separator motor turns on again to return the sliding arm. Only the top sheet is moved, and it is moved by about 25 mm.

The sliding arm stays in the same position till the first print of the next job is fed out to the paper delivery table. Then, the job separator and slider lift motors return the sliding arm to the home position.

The slider lift motor can move the sliding arm up and down through a range of approximately 60 mm. This means that the job separation function can work with up to approximately 600 sheets of paper (for 64 g/m<sup>2</sup> paper) on the paper delivery table.

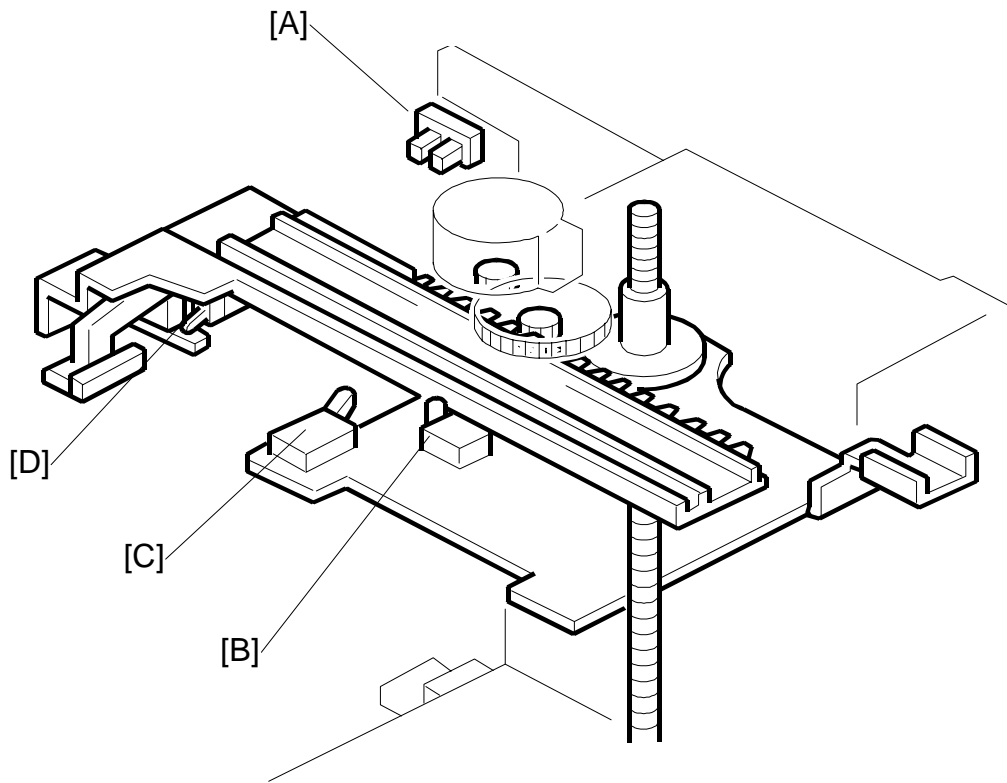
**Sliding Arm Control**

C235D049.WMF

The sliding arm moves across until the slider position sensor [B] (a micro-switch) turns on. When the sliding arm returns, the job separation motor turns until the slider HP sensor [C] (a micro-switch) turns on.

While the sliding arm is being lowered onto the top sheet of the paper stack, the paper sensor [D] (a micro-switch) turns on when the edge of the sliding arm touches the paper.

The slider upper limit sensor [A] detects when the sliding arm is at its highest possible position.

## 2.9 IMAGE UP/DOWN SHIFTING

### 2.9.1 OVERVIEW

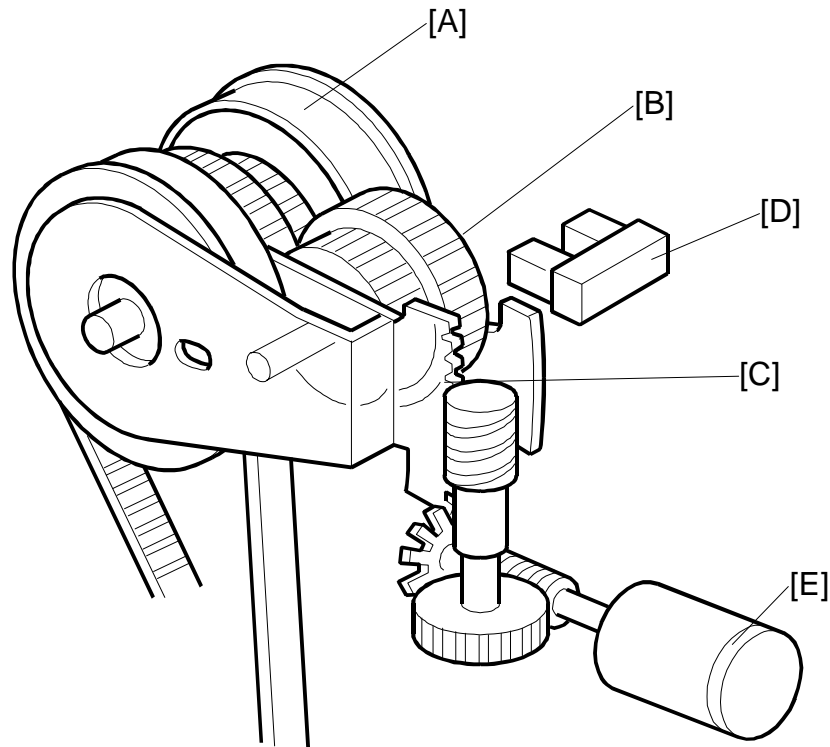

C235D036.WMF

Detailed  
Descriptions

In Image Up/Down Shifting mode, which can be operated at the operation panel, the image position on the print can be moved forward or backward with respect to the paper feed direction.

The image shift amount is controlled by changing the registration motor start timing. However, when the paper feed timing from the registration roller changes, the pressure cylinder position must also be changed so that the paper will be caught properly by the paper clamber on the pressure cylinder. This is also necessary to make sure that the printing pressure application area is correct, since the pressure cylinder cross-section is not completely circular.

The image up/down shifting mechanism changes the position of the pressure cylinder to match the amount of shift selected.

The mechanism is located in the drum drive gear [A]. It is composed of the image shift gear [B], image shift motor [E], image shift HP sensor [D], and image shift arm [C]. The HP sensor is activated when the image shifting arm is at home position.

## 2.9.2 IMAGE UP/DOWN SHIFTING MECHANISM

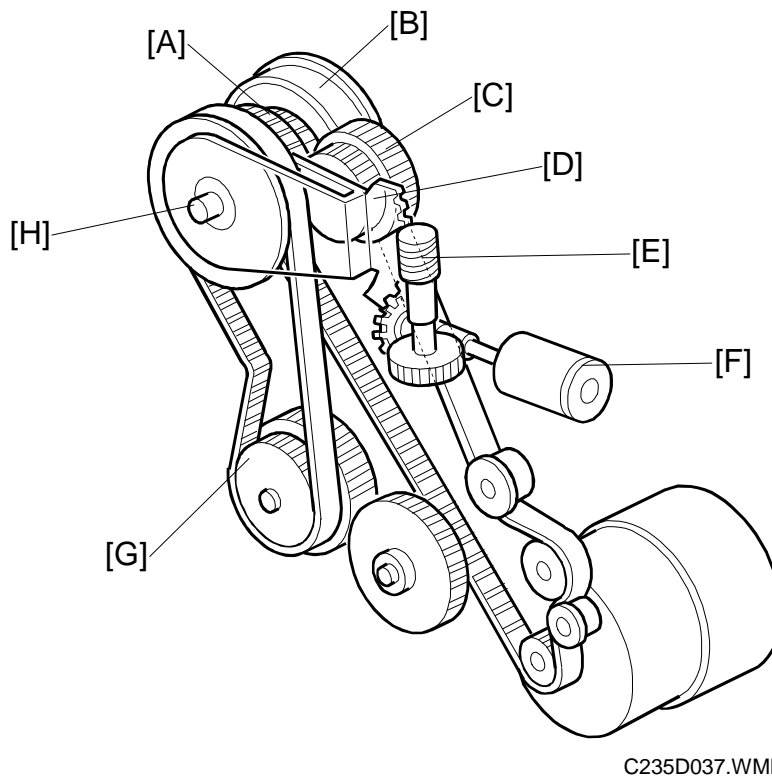

This section explains how the machine changes the position of the pressure cylinder to cope with the changed registration start timing in image shifting mode.

The image shift motor [F] turns by an amount that depends on the image shift amount selected at the operation panel. The motor drives the image shift arm [D] through the worm gear [E].

The image shift arm pivots about the shaft [H]. The image shift gear [C], attached to the image shift arm, also rotates about the shaft as it moves around the surface of the primary gear [A]. The image shift gear turns the primary gear as it moves around its surface.

The primary gear is connected to the idler pulley [G] via a timing belt. The idler pulley rotates the pressure cylinder drive gear (not shown). Therefore, moving the image shift gear up or down rotates the pressure cylinder drive gear, which changes the position of the pressure cylinder.

The drum drive gear [B] is also on the shaft [H]. However, it does not turn when the primary gear turns. Therefore, the drum stays in the same position (the home position) even though the position of the pressure cylinder changes.

In this way, a phase difference is made between the positions of the drum and pressure cylinder.

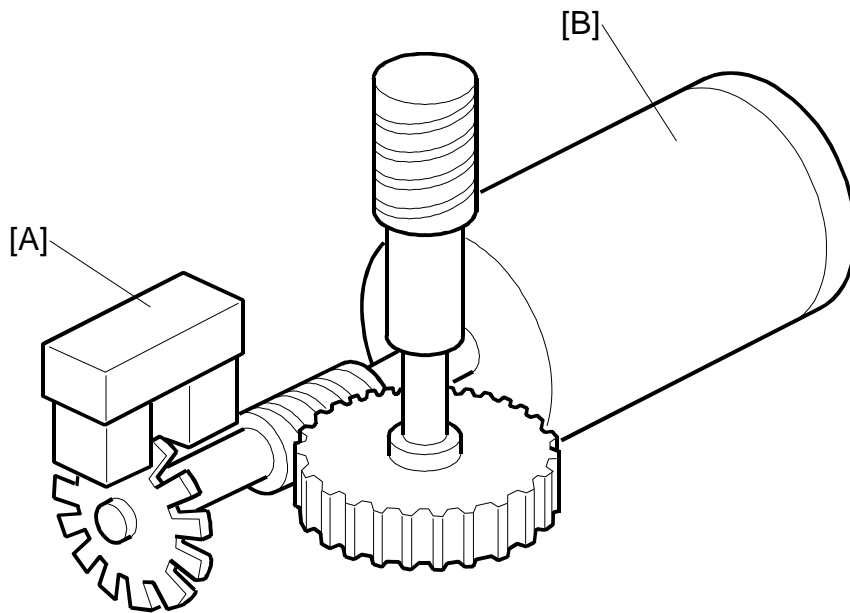

**Shifting Amount Detection**

C235D038.WMF

Detailed  
Descriptions

The image shift encoder [A] is activated by the rotation of the pulse disk on the image shift motor [B]. As the motor turns, this encoder generates a pulse signal. The CPU uses this to detect the amount of motor rotation.

The detected amount is displayed on the operation panel as the image shift amount.

When the image shifting mode is canceled, the image shift motor turns until the image shift HP sensor turns on: i.e. the shifting amount is 0.

## 2.10 ERROR DETECTION

### 2.10.1 ORIGINAL FEED ERROR DETECTION IN THE ADF

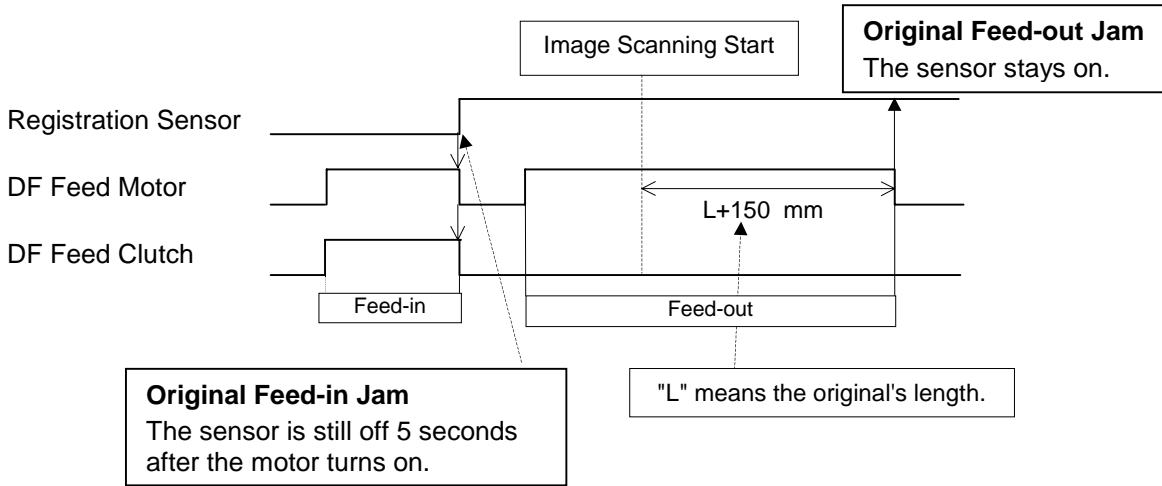

## 2.10.2 MASTER EJECT ERROR DETECTION

### Error of Master Pick-up from Drum

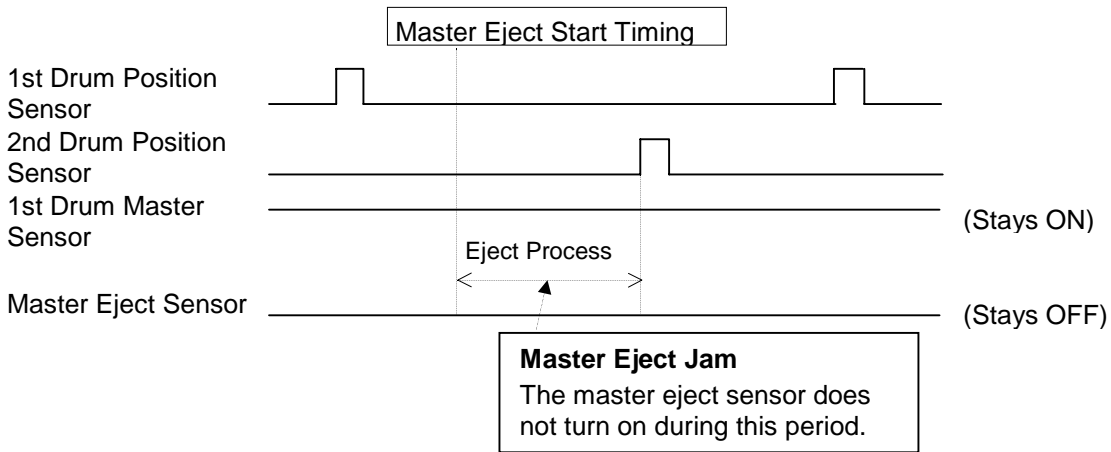

Detailed Descriptions

### Master Eject and Compression Error

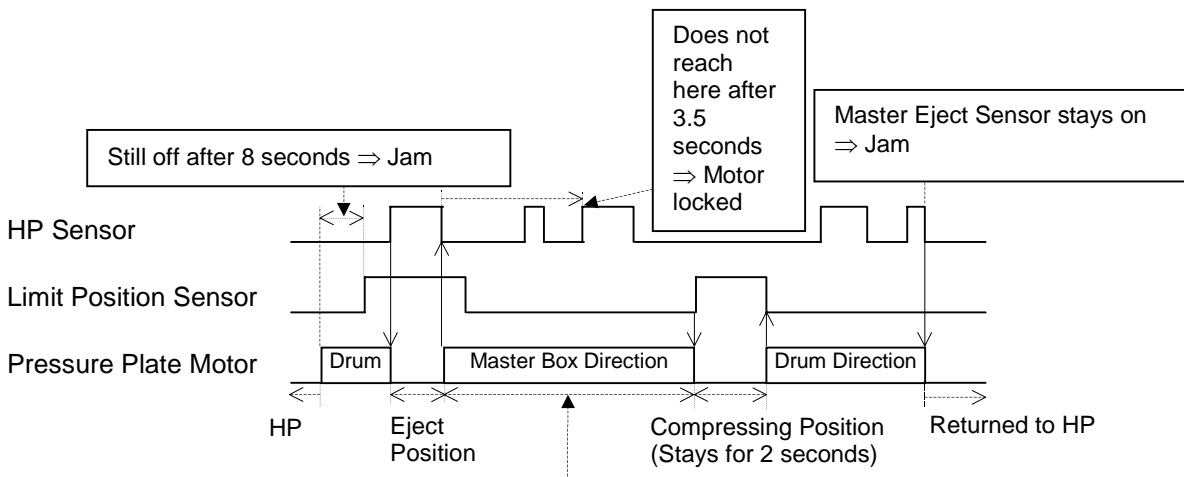

<p>Check during rotation in the master box direction</p> <p>- Check Timing - When one of the following occurs:</p> <ul style="list-style-type: none"> <li>• When Limit Position Sensor turns on.</li> <li>• 3.5 seconds passes after motor turns on.</li> </ul>	➔	<p><u>Number of HP Sensor On or Off Edges</u> (First on edge is just after motor starts.)</p> <ul style="list-style-type: none"> <li>• 5 times =&gt; Normal</li> <li>• 4 times =&gt; Master box full</li> <li>• Less than 4 =&gt; Pressure plate locked (SC06-00 lights)</li> </ul>
---	---	---

### 2.10.3 ERROR DETECTION DURING MASTER MAKING

#### Master Set and Feed Error

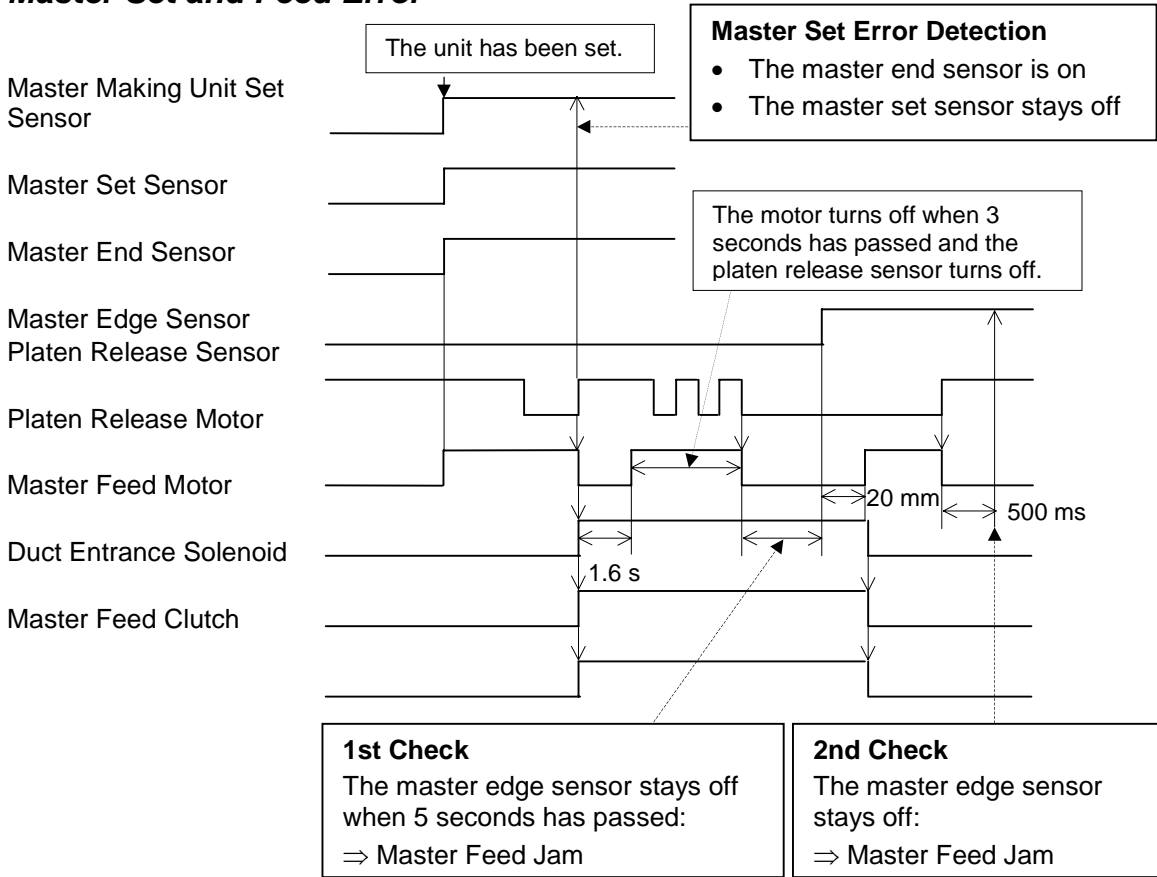

**Master Cut Error**

Detailed Descriptions

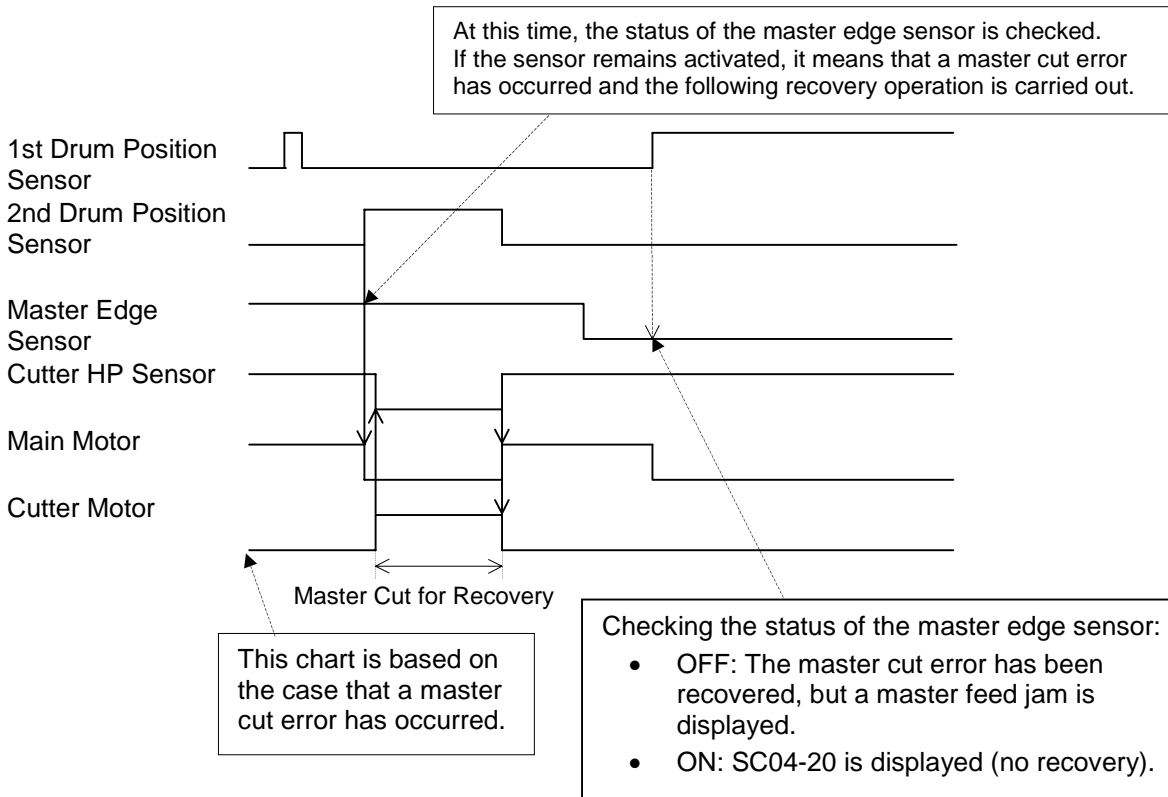

**Error During Clamping the Master to the Drum**

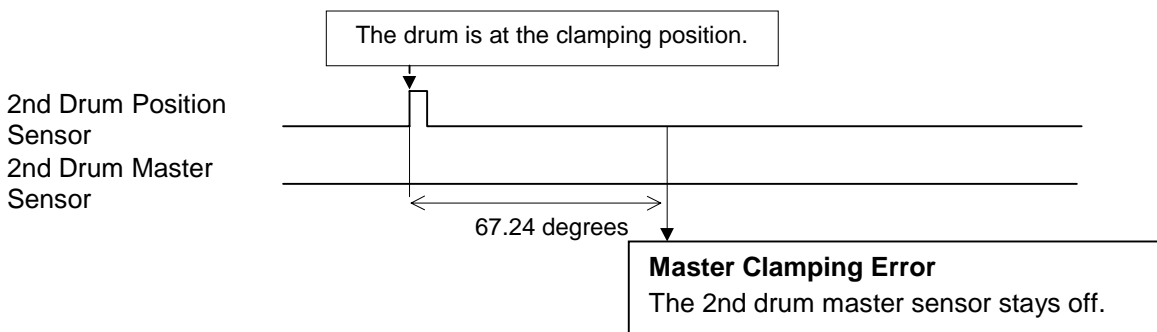

### 2.10.4 PAPER FEED ERROR DETECTION

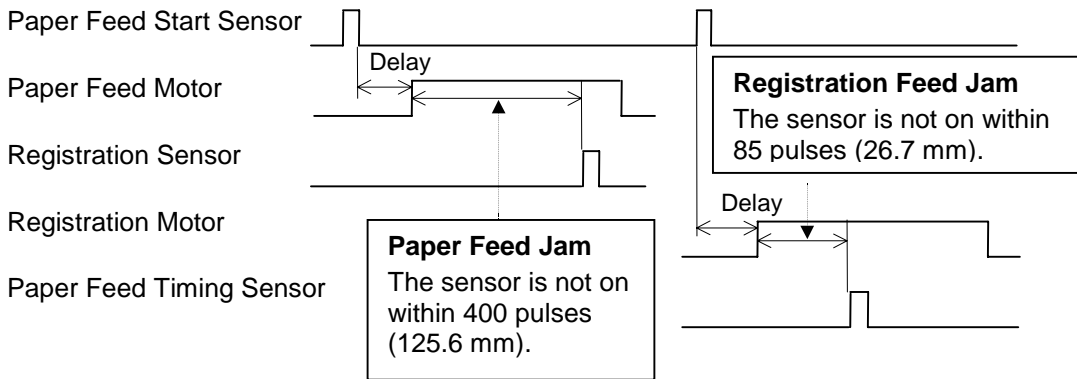

## 2.10.5 PAPER DELIVERY ERROR DETECTION

### *Paper Delivery Error*

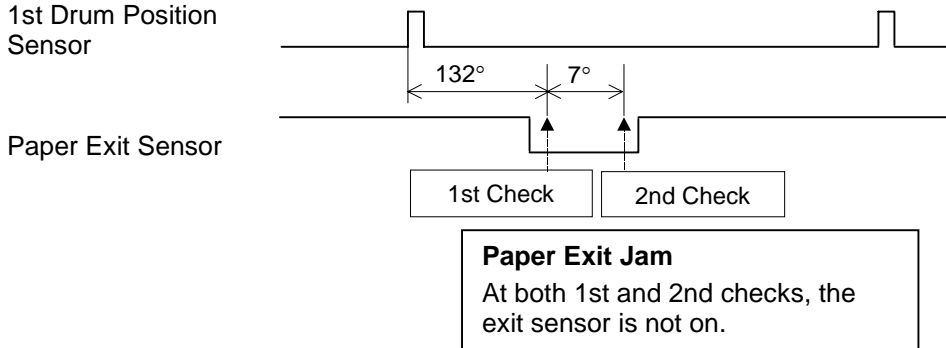

Detailed Descriptions

### *Paper Upper/Lower Wrapping Detection*

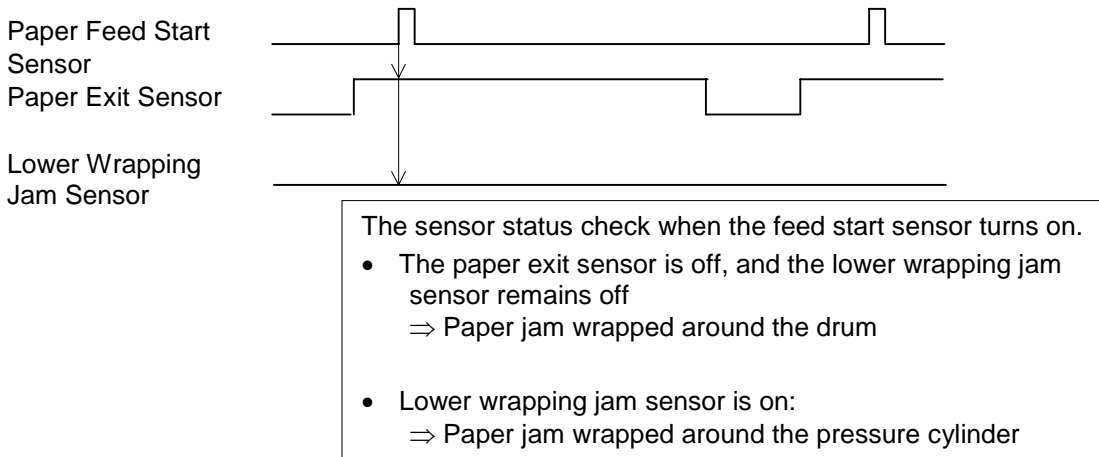

---

## 3. INSTALLATION

### 3.1 INSTALLATION REQUIREMENTS

The installation location should be carefully chosen, because the environmental conditions could greatly affect the performance of the machine.

#### 3.1.1 REQUIRED ENVIRONMENTAL CONDITIONS

1. Temperature 10 to 30°C
2. Humidity 20 to 90% RH
3. Place the machine on a strong and level base. The machine must be leveled within 5 mm both front to rear and left to right.

#### 3.1.2 ENVIRONMENTS TO AVOID

1. Locations exposed to direct sunlight or strong light (more than 1,500 lux).
2. Areas with corrosive gases.
3. Dusty areas.
4. Locations directly exposed to cool air from air conditioners or reflected heat from space heaters. (Sudden temperature changes from low to high or vice versa may cause condensation within the machine.)

#### 3.1.3 POWER CONNECTION

1. Securely connect the power cord to a power source.
2. Make sure that the wall outlet is near the machine and easily accessible.
3. Make sure the plug is firmly inserted in the outlet.
4. Avoid multi-wiring.
5. Voltage must not fluctuate more than 10%.
6. Do not press anything on the power cord.
7. Always plug the power cord into a properly grounded outlet.
8. Power Source: 220-240 V, 50/60 Hz, 1.5 A or more: 120 V, 60 Hz, 2.8 A or more. Please be sure to connect the power cord to a power source of this type.



### 3.1.4 ACCESS TO THE MACHINE

Place the machine near a power source, providing clearance, as shown below.

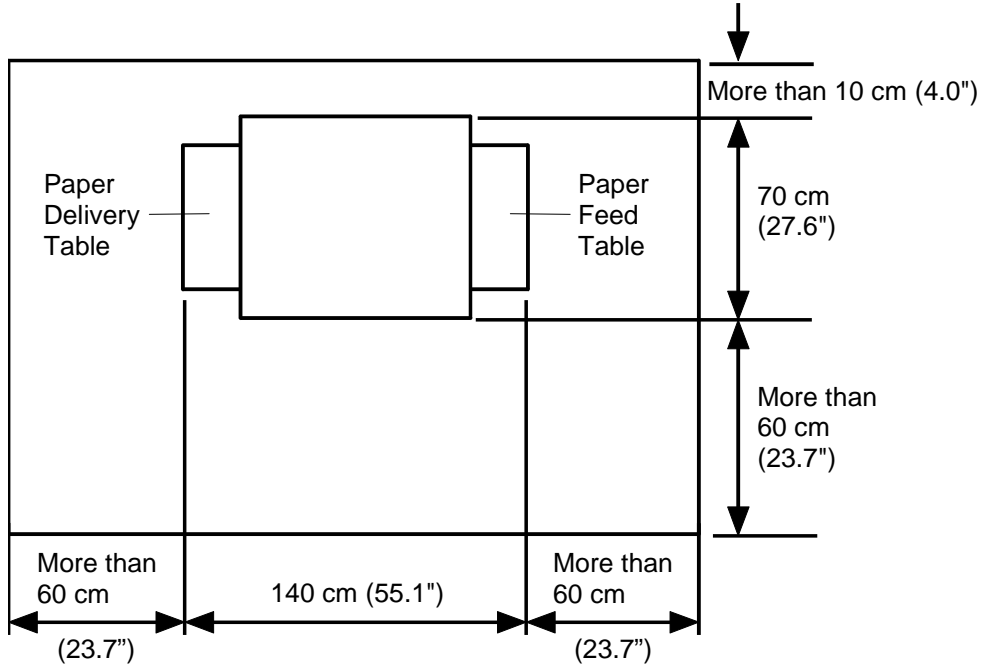

C235I500.WMF

## 3.2 INSTALLATION PROCEDURE

### 3.2.1 MAIN BODY

#### **ACCESSORY CHECK**

Make sure that you have all the accessories listed below.

Description	Quantity
1. Operating Instructions (Expect for Ricoh European Version) ....	1
2. NECR (Ricoh version only) .....	1
3. Brand Decals (OEM version only).....	1 set
4. Model Name Plates (OEM version only).....	1 set
5. Paper Delivery Table .....	1 set

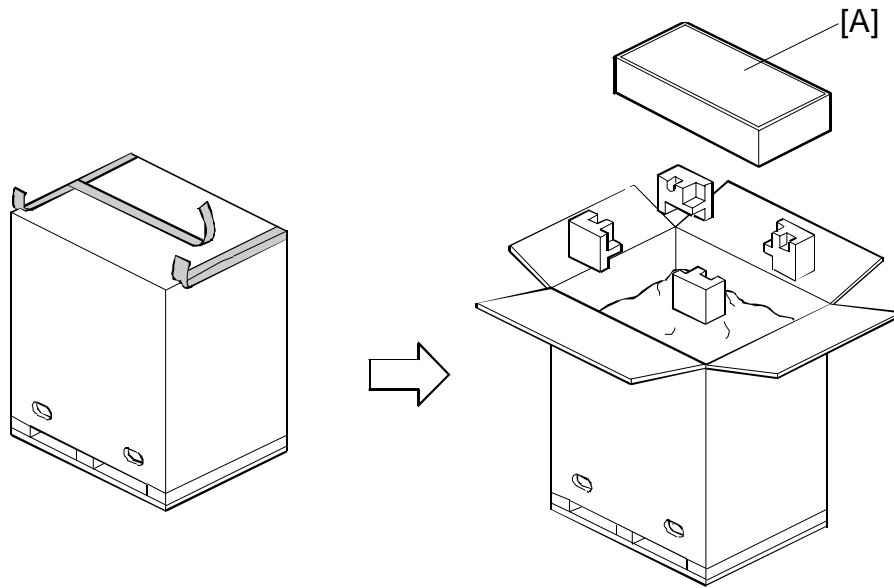

**Installation Procedure**

C235I001.WMF

**⚠ CAUTION**

**Open the box from the top. If the box is lifted off the machine from the bottom, the paper delivery table may be damaged.**

1. Unpack the box. Take out the small box [A] which contains the paper delivery table.

**NOTE:** First, open the upper opening of the box, and remove the small box inside [A]. This prevents the paper delivery table (inside the box [A]) from being damaged.

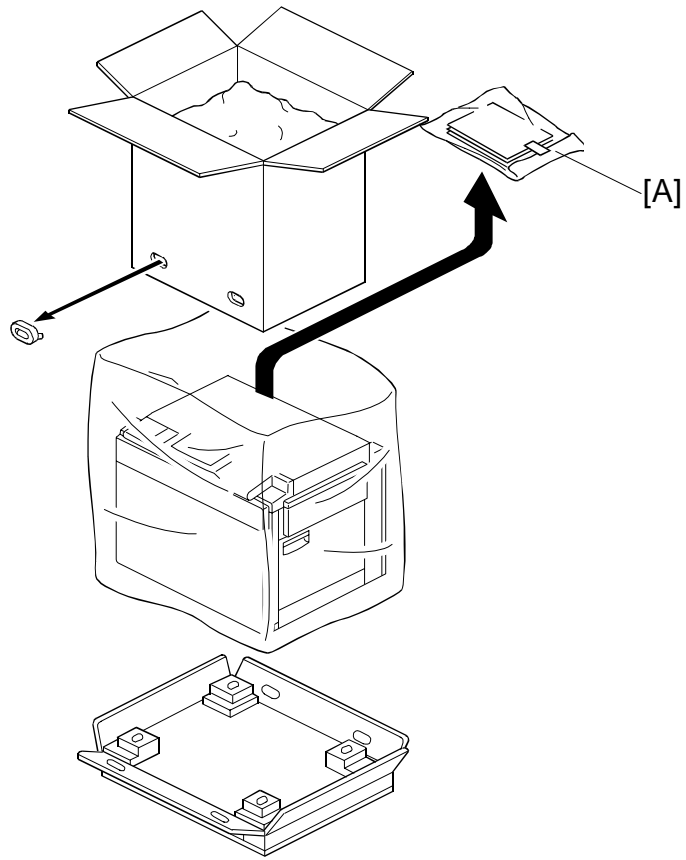

Installation

C23511005.WMF

2. Continue to unpack the box. Make sure that there are the accessory bag [A].

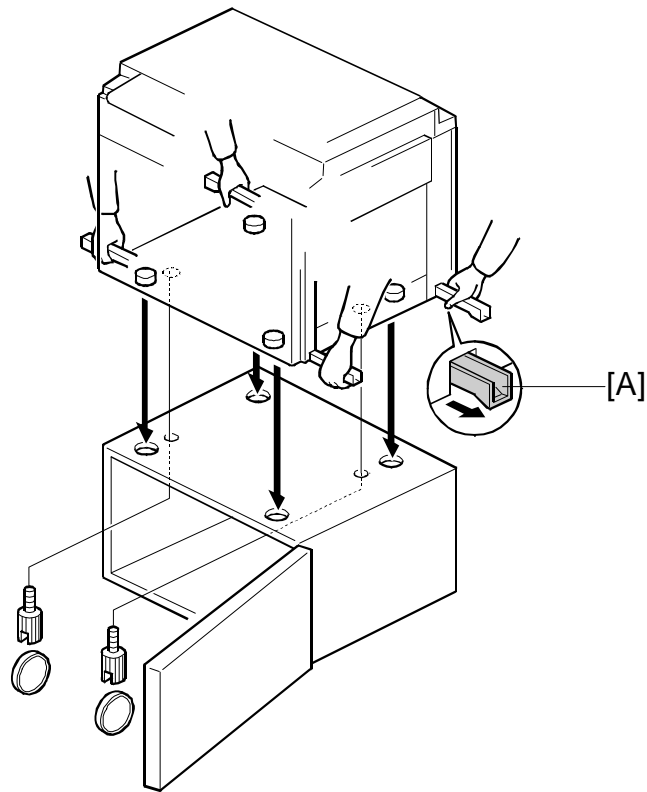

C23511006.WMF

3. When installing the optional table, mount the machine, as shown. (2 screws packed with the table).

**⚠ CAUTION**

**Only handle using the carrying handles [A] on the bottom of the machine. Otherwise, your fingers may be pinched between the main body and the table during installation. (The gap between the bottom of the main body and the table is very small.)**

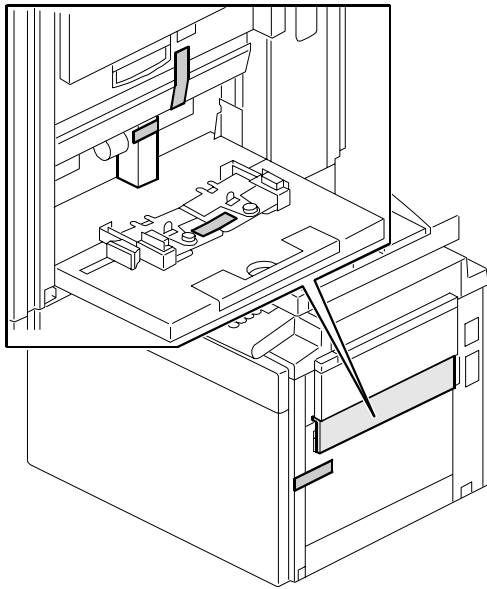

C235I004.WMF

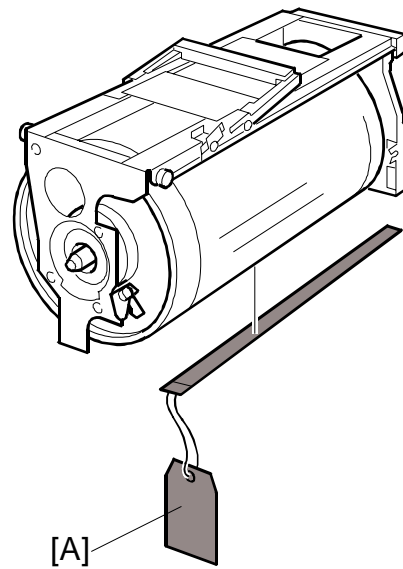

C235I031.WMF

Installation

4. Remove the tape securing the covers and units. Open the front cover, and slide out the drum unit. Then, remove the master clamber protective sheet [A].
5. Take out the paper delivery table from the box.

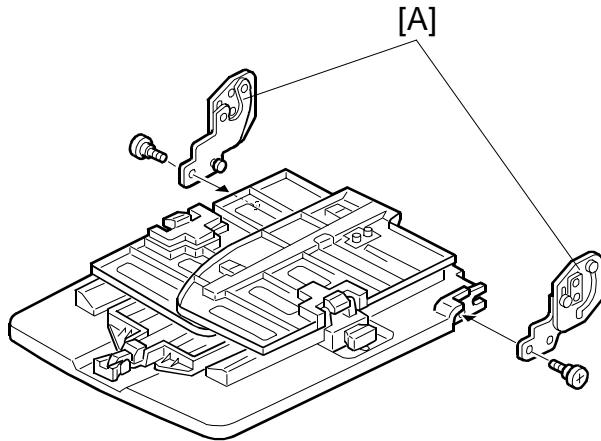

C235I017.WMF

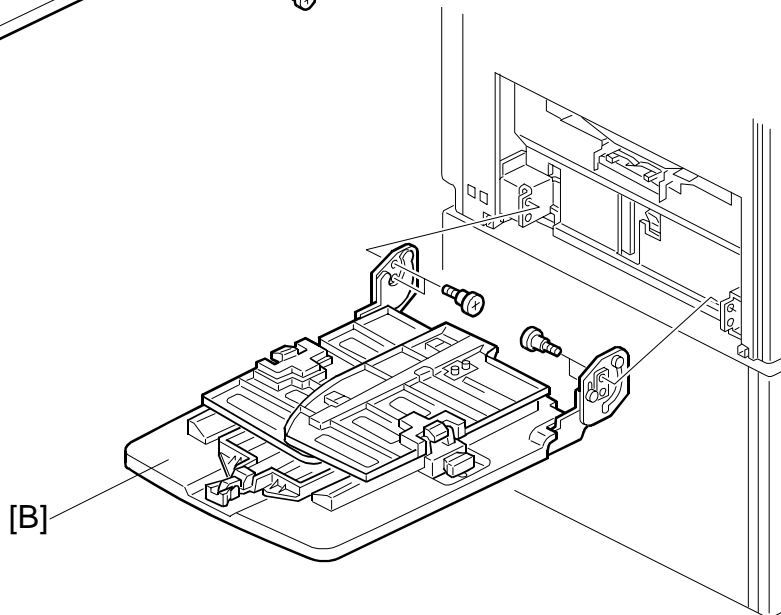

C235I015.WMF

6. Attach the front and rear arms [A] (2 screws).
7. Attach the paper delivery table [B] (2 screws).
8. Install a master roll.
9. Install an ink cartridge.
10. Firmly insert the plug in the wall outlet.  
**NOTE:** Make sure that the wall outlet is near the machine and easily accessible.
11. Turn on the main switch.
12. Press the "Economy Mode" key while holding down the "0" key, to supply ink to the drum.
13. Make test copies.

### 3.2.2 PLATEN COVER INSTALLATION (OPTION)

#### ACCESSORY CHECK

Check the quantity and condition of the accessories in the box against the following list:

Description	Quantity
1. Stepped Screw .....	2

#### INSTALLATION PROCEDURE

Installation

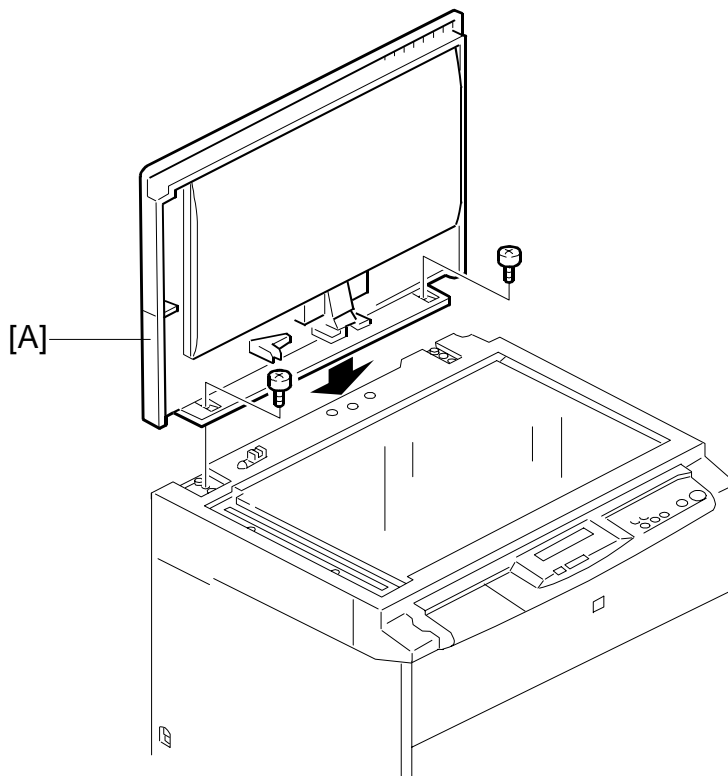

C235I1000.WMF

1. Install the platen cover [A] (2 screws).



### 3.2.3 ADF INSTALLATION (OPTION)

#### **ACCESSORY CHECK**

Check the quantity and condition of the accessories in the box against the following list:

Description	Quantity
1. Stepped Screw .....	2
2. Screws .....	3
3. Driver Tool .....	1
4. DF Exposure Glass.....	1
5. Decal - Exposure Glass .....	1
6. Decal - Scale - mm .....	1
7. Decal - Scale - inch.....	1
8. Scale Guide .....	1
9. Installation Procedure .....	1

**INSTALLATION PROCEDURE**

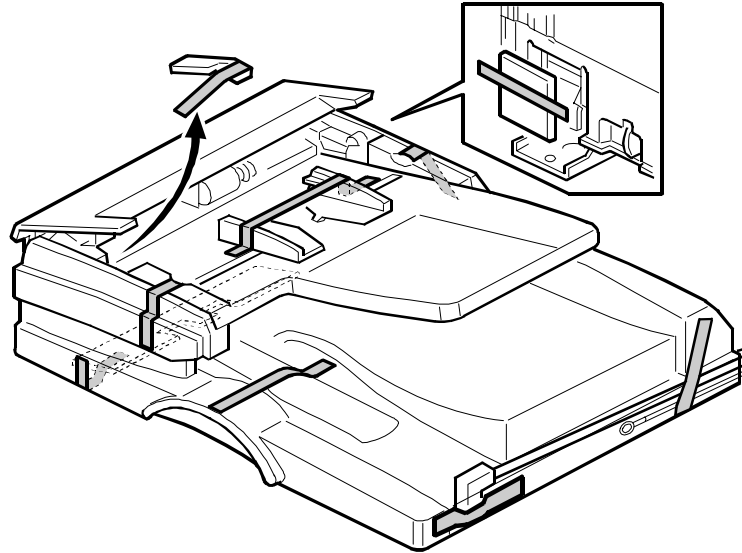

Installation

C235I1001.WMF

1. Remove the strips of tape.

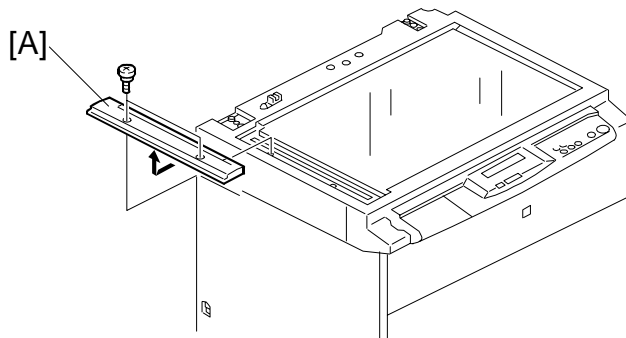

C23511002.WMF

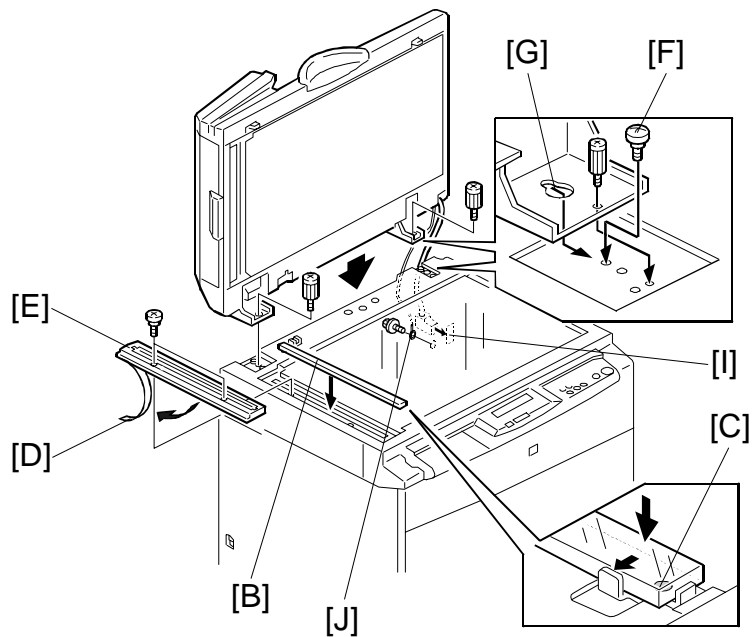

C23511003.WMF

2. Remove the left scale [A] (2 screws).
3. Place the DF exposure glass [B] on the glass holder.  
**NOTE:** When installing the DF exposure glass, make sure that the white point [C] is positioned at the lower front side, as shown.
4. Peel off the backing [D] of the double side tape attached to the rear side of the scale guide [E], then install the scale guide (2 screws removed in step 2).
5. Install the two stud screws [F].
6. Mount the DF by aligning the holes [G] in the DF with the stud screws, then slide the DF to the front as shown.
7. Secure the DF unit with two screws [H].
8. Connect the cable [I] and cable [J] to the Main body.

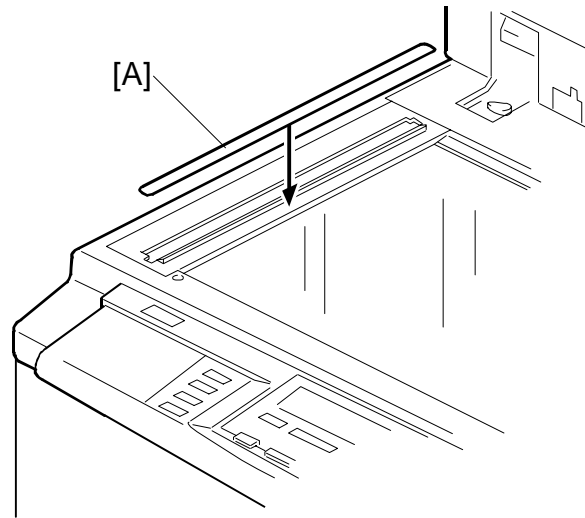

C23511004.WMF

10. Attach the decal [A] as shown.
11. Plug in the power cord, then turn the main switch on.
12. Make a full size copy from the 1st tray using the ADF. Then check to make sure the side-to-side and leading edge registrations are correct. If they are not, adjust their values.

***ADF stabilizer installation***

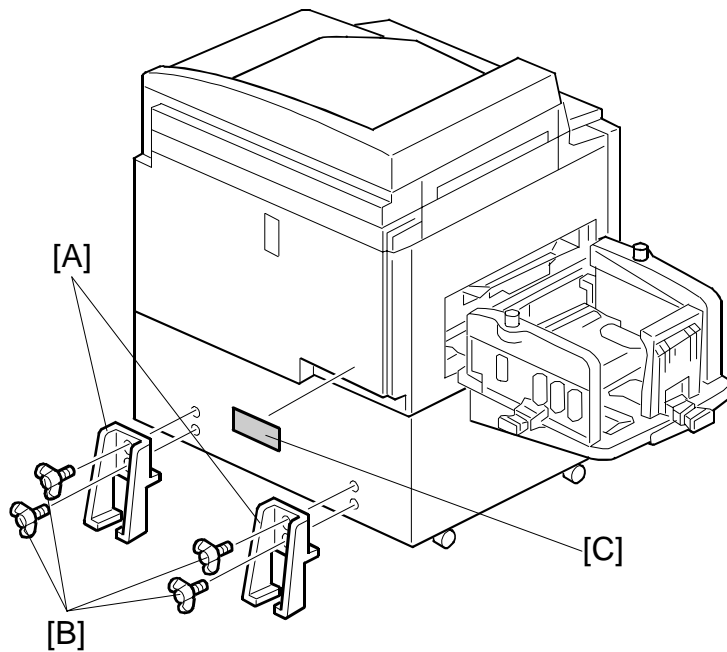

C235I500A.WMF

1. Attach the two stabilizer brackets [A] to the back of the table using the thumbscrews [B] (4 screws).
2. Attach the caution label [C], as shown.

**⚠ CAUTION**  
**This procedure must be done to prevent the machine from falling backwards when the ADF is open.**

### 3.2.4 COLOR DRUM (OPTION)

There are two types of color drum units:

- Color Drum – A3 Drum
- Color Drum – A4 Drum

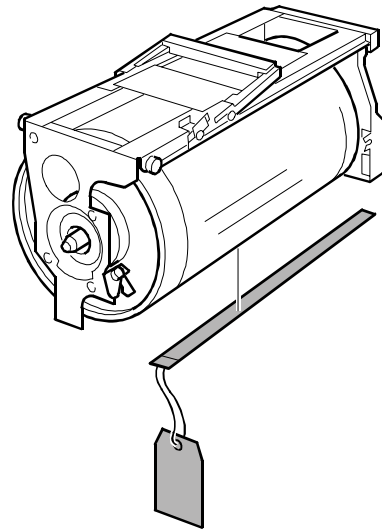
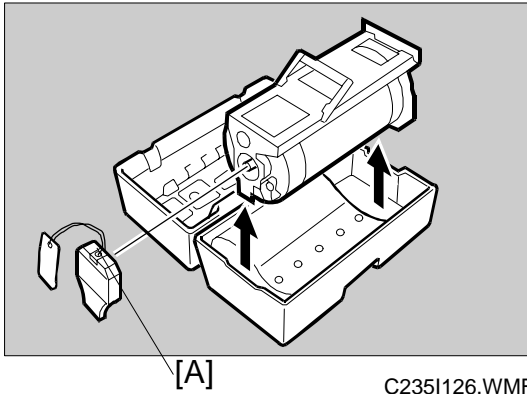

Installation

1. Take the color drum out of the drum case. Remove the holder [A].
2. Remove the protective paper in the master clamber.

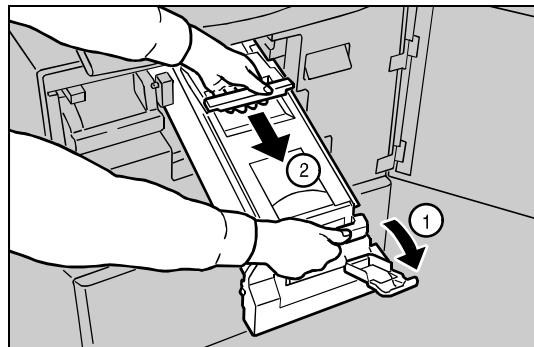
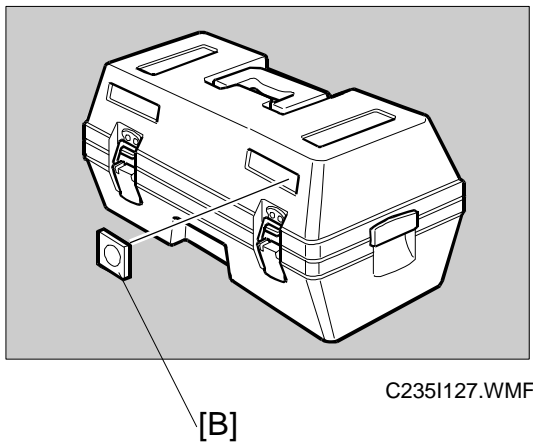

3. Attach the appropriate color decal (accessory) [B] to the drum case.
4. Remove the original drum, as shown.
5. Install the color drum in the machine.

---

## **4. SERVICE TABLE**

### **4.1 SERVICE REMARKS**

#### **4.1.1 SCANNER SECTION**

##### **1. Xenon Lamp**

Do not touch the xenon lamp while it is on, or you might receive a weak electrical shock.

##### **2. Scanner Wire Installation**

A special tool is needed. See "6.5.7 Scanner Wire".

##### **3. Sensor Board Unit (SBU) Calibration**

When the MPU is replaced or the standard white plate located behind the original scale is replaced, the SBU must be calibrated with SP6-005-1.

#### **4.1.2 MASTER EJECT SECTION**

##### **1. Master Pick-up Roller Drive Gear and Master Clamper Drive Arm Positions**

These parts must be positioned correctly. See "6.6.4 Reassembling the Master Pick-up Roller Drive Gears".

#### **4.1.3 MASTER FEED SECTION**

##### **1. Thermal Head 1**

When installing the thermal head, there are important points to note. See "Remarks for Handling the Thermal Head" in "2.2.7 Thermal Head."

##### **2. Thermal Head 2**

When replacing the thermal head, be sure to adjust the voltage supplied to the thermal head (See "6.7.6 Thermal Head Voltage Adjustment").

##### **3. Master Vacuum Fan Position**

The fan must be positioned correctly. See "6.7.5 Master Vacuum Fan Positioning".

#### ***4. Master Feed Mylar Positions***

When replacing or removing the thermal head, the cutter unit, the master duct, or the guide plate of the lower master feed control roller, the strips of mylar are easily put in the wrong position while installing the lower tension roller or lower master feed control roller. For details, refer to "6.7.10 Master Feed Mylar Positioning".

### **4.1.4 PAPER FEED SECTION**

#### ***1. Paper Feed Roller and Paper Separation Roller 1***

Be careful to install the rollers the correct way around. They have a one-way clutch inside.

#### ***2. Paper Feed Roller and Paper Separation Roller 2***

Do not touch the surfaces of the rollers with bare hands.

### **4.1.5 DRUM AND DRUM DRIVE SECTION**

#### ***1. Doctor Roller***

Normally the doctor roller gap is not adjusted or changed. It tends to be difficult to adjust in the field. If the gap becomes narrower, an uneven image may appear on the prints. If it becomes wider, too much ink will be applied to the drum screens, resulting in ink leakage from the drum.

#### ***2. Drum Master Clamper***

- 1) Do not allow the inside of the clamping plate to become dirty with ink.
- 2) Do not use alcohol or other solvents to clean the inside of the clamping plate. Use a cloth dampened with water.

#### ***3. Ink Roller Unit***

Do not disassemble the ink roller unit. Each part between the front and rear side plates of this unit has been precisely adjusted on the production line to keep the doctor and ink rollers parallel against the drum shaft.



## 4.1.6 MAIN DRIVE SECTION

### 1. *Main Drive Adjustment*

Special tools are needed for the adjustment. For details, see "6.11.2 Main Drive Mechanism (Main Timing Belt)".

## 4.1.7 ELECTRICAL COMPONENTS

### 1. *Main Processing Unit (MPU) and I/O Board*

After replacing the MPU or I/O board, some adjustments are needed. See "6.3 MPU and I/O Board Replacement".

### 2. *Main Processing Unit (MPU) and Power Supply Unit*

To access the rear of the machine, the MPU and I/O board have to be moved out of the way. See "6.4 MPU and PSU Opening Procedures".

### 3. *Power Supply Unit*

When replacing the power supply unit, be sure to adjust the voltage supplied to the thermal head. See "6.7.6 Thermal Head Voltage Adjustment".

### 4. *Program Update*

To update the software in the flash ROM on the MPU, a special tool is needed. See "4.5.3 Load Program (SP8-2)".

### 5. *Sensor Adjustments*

Adjustment is needed for the following sensors

- 1st drum master sensor
- 2nd drum master sensor
- Master eject sensor
- Master edge sensor
- Master end sensor

For details, see the adjustment procedures for each sensor in section 6.

## 4.2 DIP SW, LED, VR, TP, AND FUSE TABLES

### 4.2.1 TEST POINTS

#### *Ink Detection Board*

Number	Usage
TP1	Ink Level
TP2	Ink Level
TP-12V	-12V

### 4.2.2 DIP SWITCHES

#### *Ink Detection Board*

Number	Standard A3 Drum	Optional A3 Drum	Optional A4 Drum	Not used
DPS901-1	ON	OFF	ON	OFF
DPS901-2	ON	ON	OFF	OFF

#### *Operation Panel Board*

There are dip switches (DPS1, 2, 3, and 4) behind the operation panel. Do not change the settings. All dip switches must be in OFF positions.

### 4.2.3 POTENTIOMETERS

#### *I/O Board*

Number	Usage
VR303	Master Eject Sensor Adjustment
VR304	Master End Sensor Adjustment (Do not adjust.)
VR305	1st Drum Master Sensor Adjustment
VR306	2nd Drum Master Sensor Adjustment
VR307	Master Edge Sensor Adjustment

#### *Power Supply Board*

Number	Usage
VR1	Thermal Head Voltage Adjustment

#### *Ink Detection Board*

Number	Usage
VR901	Ink Detection Board Adjustment

## 4.2.4 LED'S

### *MPU*

Number	Function
LED101	Monitors the CPU operation. Usually, this LED is blinking.
LED102	Monitors power supplied to the MPU. Usually, this LED is lit.

### *I/O Board*

Number	Function
LED300	Monitors the Master Eject Sensor.
LED301	Monitors the Master Edge Sensor.
LED302	Monitors the 1st Drum Master Sensor.
LED303	Monitors the 2nd Drum Master Sensor.
LED304	Monitors the feed control CPU operation. Usually, this LED is blinking.

## 4.2.5 FUSES

### *Power Supply Unit*

Fuse	Rated Current	Protect
FU700	10A	Power Supply Unit
FU701	5A	I/O Board
FU702	5A	I/O Board
FU703	5A	Main Motor Drive Board
FU704	5A	Main Motor Drive Board

### *Main Motor Control Board*

Fuse	Rated Current	Protect
FUSE	10A	Main Motor

### 4.3 SERVICE CALL CODES

Code	Title	Conditions	Possible Causes
SC01-00	MPU NVRAM data error	When NVRAM data is abnormal after downloading new firmware.	<ul style="list-style-type: none"> <li>• Program download error</li> <li>• Defective NVRAM</li> </ul>
SC01-01	MPU Flash ROM error	When the flash ROM cannot be accessed for downloading the data.	<ul style="list-style-type: none"> <li>• Defective Flash ROM</li> </ul>
SC02-00	Scanner motor lock (the HP sensor remains off)	After the scanner has left home position, it does not return there for more than 7 seconds.	<ul style="list-style-type: none"> <li>• Defective scanner HP sensor</li> <li>• Scanner wire slip-off</li> <li>• Defective scanner motor</li> </ul>
	Scanner motor lock (the HP sensor remains on)	At power on or when the Start key is pressed, the scanner does not move from the home position towards the scanning direction for more than 2 seconds.	<ul style="list-style-type: none"> <li>• Defective scanner HP sensor</li> <li>• Scanner wire slip-off</li> <li>• Defective scanner motor</li> </ul>
	Scanner motor lock (the scanner does not return to HP)	At power on, the scanner does not return to the home position within 2 seconds after it left.	<ul style="list-style-type: none"> <li>• Defective scanner HP sensor</li> <li>• Scanner wire slip-off</li> <li>• Defective scanner motor</li> </ul>
SC03-00	Thermal head ID error	The CPU detects an abnormal ID signal from the thermal head.	<ul style="list-style-type: none"> <li>• Defective thermal head</li> <li>• Defective MPU</li> </ul>
SC03-01	Thermal head energy pulse error	The CPU detects an abnormal thermal head energy control pulse.	<ul style="list-style-type: none"> <li>• Defective MPU</li> <li>• Defective PSU</li> </ul>
SC03-02	Thermal head thermistor short	The signal from the thermal head thermistor reaches 4.88 volts.	<ul style="list-style-type: none"> <li>• Thermistor open circuit</li> <li>• Related connector disconnected</li> </ul>
SC03-03	Thermal head temperature abnormal	When the Start key is pressed, a temperature of 54 °C or more is detected at the thermal head.	<ul style="list-style-type: none"> <li>• Thermistor short</li> <li>• Defective thermal head</li> </ul>
SC04-00	Cutter HP sensor remains on	The cutter does not leave the home position for more than 3 seconds after the cutter motor on signal is generated.	<ul style="list-style-type: none"> <li>• Defective sensor</li> <li>• Defective motor</li> <li>• Jammed master</li> </ul>
	Cutter HP sensor remains off	After leaving home position, the cutter does not return there for more than 3 seconds.	<ul style="list-style-type: none"> <li>• Defective sensor</li> <li>• Defective motor</li> <li>• Jammed master</li> </ul>
SC04-10	Platen release sensor remains on	The sensor is not de-activated for more than 5 seconds after the platen release motor on signal is generated.	<ul style="list-style-type: none"> <li>• Defective sensor</li> <li>• Defective motor</li> </ul>

<b>Code</b>	<b>Title</b>	<b>Conditions</b>	<b>Possible Causes</b>
<b>SC04-11</b>	Platen release sensor remains off	The sensor is not activated for more than 5 seconds after the platen release motor on signal is generated.	<ul style="list-style-type: none"> <li>• Defective sensor</li> <li>• Defective motor</li> </ul>
<b>SC04-20</b>	Master cut error	The master edge sensor remains on even after the first master cut recovery operation. (Normally, the master is cut if the master edge sensor detects a mis-cut master the first time.)	<ul style="list-style-type: none"> <li>• Defective master edge sensor</li> <li>• Defective cutter unit</li> <li>• Defective master vacuum fans</li> <li>• Jammed master</li> </ul>
<b>SC05-00</b>	Main motor lock (1st drum position sensor does not turn on)	At power on or when the drum returns to home position, the 1st drum position sensor is not activated for more than 5 seconds after the main motor on signal is generated.	<ul style="list-style-type: none"> <li>• Defective sensor</li> <li>• Defective main motor</li> </ul>
<b>SC05-01</b>	Main motor lock (motor control signal error)	The CPU on the motor control board detects an abnormal signal from the main motor encoder.	<ul style="list-style-type: none"> <li>• Defective main motor</li> <li>• Jammed master</li> </ul>
<b>SC05-02</b>	Drum HP sensor remains off	The sensor is not activated after the main motor on signal is generated.	<ul style="list-style-type: none"> <li>• Defective sensor</li> </ul>
<b>SC05-10</b>	Image shift HP sensor remains on or off	At power on, the sensor signal does not change for more than 25 seconds after the image shift motor on signal is generated.	<ul style="list-style-type: none"> <li>• Defective sensor</li> <li>• Defective motor</li> </ul>
<b>SC05-12</b>	No image position encoder pulse	At power on or when the image up/down shift mode is selected, the CPU detects no encoder pulse from the sensor for more than 25 seconds after the image shift motor on signal is generated.	<ul style="list-style-type: none"> <li>• Defective sensor</li> </ul>
<b>SC05-20</b>	Drum shift HP sensor remains on or off	At power on, the sensor signal does not change for more than 6 seconds after the drum shift motor on signal is generated.	<ul style="list-style-type: none"> <li>• Defective sensor</li> <li>• Defective motor</li> </ul>
<b>SC05-22</b>	No drum shift sensor pulse	At power on or when the image side-to-side shift mode is selected, the CPU detects no encoder pulse from the sensor for more than 6 seconds after the drum shift motor on signal is generated.	<ul style="list-style-type: none"> <li>• Defective sensor</li> </ul>
<b>SC05-30</b>	Drum thermistor open	The signal from the thermistor beside the ink detecting pins reaches 4.5 volts.	<ul style="list-style-type: none"> <li>• Thermistor circuit open</li> <li>• Related connector disconnected</li> </ul>

<b>Code</b>	<b>Title</b>	<b>Conditions</b>	<b>Possible Causes</b>
<b>SC05-31</b>	Drum thermistor short	The thermistor beside the ink detecting pins detects an excessively high temperature (96 °C).	<ul style="list-style-type: none"> <li>• Thermistor short</li> </ul>
<b>SC05-32</b>	Ink pump sensor remains on or off	The sensor signal does not change status after the ink pump motor on signal is generated.	<ul style="list-style-type: none"> <li>• Defective sensor</li> <li>• Defective motor</li> <li>• Jammed ink pump drive</li> </ul>
<b>SC05-40</b>	A4 cam sensor remains on or off	The sensor does not change status for more than 6 seconds after the pressure cam shift motor on signal is generated.	<ul style="list-style-type: none"> <li>• Defective sensor</li> <li>• Defective motor</li> </ul>
<b>SC05-41</b>	A3 cam sensor remains off or on	The sensor does not change status for more than 6 seconds after the pressure cam shift motor on signal is generated.	<ul style="list-style-type: none"> <li>• Defective sensor</li> <li>• Defective motor</li> </ul>
<b>SC05-50</b>	Clamper close position sensor remains on when opening the clamper	When the master clamper is being opened, the sensor is not de-activated for more than 4 seconds after the clamper motor on signal is generated.	<ul style="list-style-type: none"> <li>• Defective sensor</li> <li>• Defective motor</li> <li>• Jammed drum guide drive</li> <li>• Defective 2nd drum position sensor</li> <li>• Defective MPU</li> <li>• Defective main motor</li> </ul>
	Clamper close position sensor remains off when closing the clamper	When the master clamper is being closed, the sensor is not activated for more than 4 seconds after the clamper motor on signal is generated.	<ul style="list-style-type: none"> <li>• Defective sensor</li> <li>• Defective motor</li> <li>• Jammed drum guide drive</li> </ul>
<b>SC05-51</b>	Clamper open position sensor remains off when opening the clamper	When the master clamper is being opened, the sensor is not activated for more than 4 seconds after the clamper motor on signal is generated.	<ul style="list-style-type: none"> <li>• Defective sensor</li> <li>• Defective motor</li> <li>• Jammed drum guide drive</li> <li>• Defective 2nd drum position sensor</li> </ul>
	Clamper open position sensor remains on when opening the clamper	When the master clamper is being opened, the sensor is not de-activated for more than 4 seconds after the clamper motor on signal is generated.	<ul style="list-style-type: none"> <li>• Defective sensor</li> <li>• Defective motor</li> <li>• Jammed drum guide drive</li> </ul>
	Clamper open position sensor remains off when closing the clamper	When the master clamper is being closed, the sensor is not activated for more than 4 seconds after the clamper motor on signal is generated.	<ul style="list-style-type: none"> <li>• Defective sensor</li> <li>• Defective motor</li> <li>• Jammed drum guide drive</li> </ul>



Code	Title	Conditions	Possible Causes
SC05-51	Clamper open position sensor remains on when closing the clamper	When the master clamper is being closed, the sensor is not de-activated for more than 4 seconds after the clamper motor on signal is generated.	<ul style="list-style-type: none"> <li>Defective sensor</li> <li>Defective motor</li> <li>Jammed drum guide drive</li> </ul>
SC05-60	Idling HP sensor remains on or off	The sensor does not change status after the idling roller motor on signal is generated.	<ul style="list-style-type: none"> <li>Defective sensor</li> <li>Defective motor</li> </ul>
SC06-00	Pressure plate does not move from home to the master eject ready position	The pressure plate does not reach the master eject ready position after it has left home for more than 3 seconds after the pressure plate motor on signal is generated.	<ul style="list-style-type: none"> <li>Defective sensor</li> <li>Defective motor</li> <li>Jammed master</li> </ul>
	Pressure plate does not return to the home position	The pressure plate does not reach the home position for more than 6 seconds after the pressure plate motor on signal is generated.	<ul style="list-style-type: none"> <li>Defective sensor</li> <li>Defective motor</li> <li>Jammed master</li> </ul>
	Pressure plate does not move to the compression position	The pressure plate does not reach home while traveling from the master eject ready position to the compression position for more than 6 seconds after the pressure plate motor on signal is generated.	<ul style="list-style-type: none"> <li>Defective sensor</li> <li>Defective motor</li> <li>Jammed master</li> </ul>
SC07-00	Sensor 0 in the feed pressure detection board remains on or off	The sensor does not change status.	<ul style="list-style-type: none"> <li>Defective feed pressure detection board</li> <li>Defective feed pressure motor</li> </ul>
	Sensor 1 in the feed pressure detection board remains on or off	The sensor does not change status.	<ul style="list-style-type: none"> <li>Defective feed pressure detection board</li> <li>Defective feed pressure motor</li> </ul>
	Sensor 2 in the feed pressure detection board remains on or off	The sensor does not change status.	<ul style="list-style-type: none"> <li>Defective feed pressure detection board</li> <li>Defective feed pressure motor</li> </ul>
	Sensor 3 in the feed pressure detection board remains on or off	The sensor does not change status.	<ul style="list-style-type: none"> <li>Defective feed pressure detection board</li> <li>Defective feed pressure motor</li> </ul>

Code	Title	Conditions	Possible Causes
SC07-10	Sensor 0 in the separation pressure detection board remains on or off	The sensor does not change status.	<ul style="list-style-type: none"> <li>Defective separation pressure detection board</li> <li>Defective separation pressure motor</li> </ul>
	Sensor 1 in the separation pressure detection board remains on or off	The sensor does not change status.	<ul style="list-style-type: none"> <li>Defective separation pressure detection board</li> <li>Defective separation pressure motor</li> </ul>
	Sensor 2 in the separation pressure detection board remains on or off	The sensor does not change status.	<ul style="list-style-type: none"> <li>Defective separation pressure detection board</li> <li>Defective separation pressure motor</li> </ul>
	Sensor 3 in the separation pressure detection board remains on or off	The sensor does not change status.	<ul style="list-style-type: none"> <li>Defective separation pressure detection board</li> <li>Defective separation pressure motor</li> </ul>
SC07-20	Feed encoder error	The CPU detects an abnormal signal from the feed encoder.	<ul style="list-style-type: none"> <li>Defective I/O board</li> <li>Defective sensor</li> </ul>
SC07-21	Paper table feed start sensor error	The sensor is not activated for more than 5 seconds after the main motor on signal is generated.	<ul style="list-style-type: none"> <li>Defective sensor</li> </ul>
SC07-22	Tray feed start sensor error	The sensor is not activated for more than 5 seconds after the main motor on signal is generated.	<ul style="list-style-type: none"> <li>Defective sensor</li> </ul>
SC07-30	Friction pad motor lock	The sensor's status remains the same after the motor turns for 5 seconds.	<ul style="list-style-type: none"> <li>Defective sensor</li> <li>Defective motor</li> </ul>
SC07-50	Wing <u>lower</u> position sensor remains <u>on</u>	When the wing guide moves upwards, the sensor is not deactivated for more than 6 seconds after the wing guide motor on signal is generated.	<ul style="list-style-type: none"> <li>Defective sensor</li> <li>Defective motor</li> </ul>
	Wing <u>lower</u> position sensor remains <u>off</u>	When the wing guide moves downwards, the sensor is not activated for more than 6 seconds after the wing guide motor on signal is generated.	<ul style="list-style-type: none"> <li>Defective sensor</li> <li>Defective motor</li> </ul>
SC07-51	Wing <u>upper</u> position sensor remains <u>off</u>	When the wing guide moves upwards, the sensor is not activated for more than 6 seconds after the wing guide motor on signal is generated.	<ul style="list-style-type: none"> <li>Defective sensor</li> <li>Defective motor</li> </ul>



Code	Title	Conditions	Possible Causes
SC07-51	Wing <u>upper</u> position sensor remains <u>on</u>	When the wing guide moves downwards, the sensor is not de-activated for more than 6 seconds after the wing guide motor on signal is generated.	<ul style="list-style-type: none"> <li>• Defective sensor</li> <li>• Defective motor</li> </ul>
SC07-60	Slider paper sensor (in the job separator) remains on	When the slider moves upwards, the sensor is not de-activated for more than 9 seconds after the slider lift motor on signal is generated.	<ul style="list-style-type: none"> <li>• Defective sensor</li> <li>• Defective motor</li> <li>• Defective job separator board</li> </ul>
	Slider paper sensor (in the job separator) remains off	When the slider moves downwards, the sensor is not activated for more than 9 seconds after the slider lift motor on signal is generated.	<ul style="list-style-type: none"> <li>• Defective sensor</li> <li>• Defective motor</li> <li>• Defective job separator board</li> </ul>
SC07-61	Slider upper limit sensor remains <u>off</u>	When the slider moves upwards, the sensor is not activated for more than 9 seconds after the slider lift motor on signal is generated.	<ul style="list-style-type: none"> <li>• Defective sensor</li> <li>• Defective motor</li> <li>• Defective job separator board</li> </ul>
	Slider upper limit sensor remains <u>on</u>	When the slider moves downwards, the sensor is not de-activated for more than 9 seconds after the slider lift motor on signal is generated.	<ul style="list-style-type: none"> <li>• Defective sensor</li> <li>• Defective motor</li> <li>• Defective job separator board</li> </ul>
SC07-70	Slider HP sensor remains on	When the slider moves toward the delivery table, the sensor is not de-activated for more than 6 seconds after the job separator motor on signal is generated.	<ul style="list-style-type: none"> <li>• Defective sensor</li> <li>• Defective motor</li> <li>• Defective job separator board</li> </ul>
SC07-72	Slider position sensor remains on or off, when the slider returns	When the slider returns, the sensor signal does not change status for more than 6 seconds after the job separator motor on signal is generated.	<ul style="list-style-type: none"> <li>• Defective sensor</li> <li>• Defective motor</li> <li>• Defective job separator board</li> </ul>
SC20-00	Memory board error	The CPU cannot detect a signal from the memory board (the editing function board).	<ul style="list-style-type: none"> <li>• Defective memory board</li> <li>• Cable disconnected</li> </ul>
SC21-00	Memory control ASIC error	The machine detects a failure in the memory control ASIC.	<ul style="list-style-type: none"> <li>• Defective ASIC or RAM on memory board</li> </ul>
SC22-00	Make-up RAM error	The RAM for the make-up pattern data cannot be reset.	<ul style="list-style-type: none"> <li>• Defective memory board</li> </ul>
SC30-00	Paper table lower limit sensor remains on or off	When the table moves upwards, the sensor does not change status for more than 7.5 seconds after the paper table motor on signal is generated.	<ul style="list-style-type: none"> <li>• Defective sensor</li> <li>• Defective motor</li> </ul>

<b>Code</b>	<b>Title</b>	<b>Conditions</b>	<b>Possible Causes</b>
<b>SC30-01</b>	Paper table height sensor remains off or on	When the table moves upwards, the sensor does not change status for more than 7.5 seconds after the paper table motor on signal is generated.	<ul style="list-style-type: none"> <li>• Defective sensor</li> <li>• Defective motor</li> </ul>
<b>SC31-10</b>	Abnormal right tandem tray bottom plate position detection	When the bottom plate moves upwards, the sensor is not activated for more than 7.5 seconds after the right tray lift motor on signal is generated.	<ul style="list-style-type: none"> <li>• Defective sensor in the right side of tray 1</li> <li>• Defective motor</li> <li>• Detective tray wires</li> </ul>
<b>SC31-11</b>	Abnormal left tandem tray bottom plate position detection	When the bottom plate moves upwards, the sensor is not activated for more than 7.5 seconds after the left tray lift motor on signal is generated.	<ul style="list-style-type: none"> <li>• Defective sensor in the left side of tray 1</li> <li>• Defective motor</li> <li>• Detective tray wires</li> </ul>
<b>SC31-12</b>	Abnormal back plate position detection	When the back plate moves, the sensor is not activated for more than 7.6 seconds after the back plate drive motor on signal is generated.	<ul style="list-style-type: none"> <li>• Defective back plate home position or return sensor</li> <li>• Defective motor</li> </ul>
<b>SC31-13</b>	Abnormal right tandem tray position detection	When the tandem tray is being drawn out, the sensor is not activated for more than 1 second.	<ul style="list-style-type: none"> <li>• Defective connector</li> </ul>
<b>SC31-20</b>	Abnormal tray 2 bottom plate position detection	When the bottom plate moves upwards, the sensor is not activated for more than 4 seconds after the tray 2 lift motor on signal is generated.	<ul style="list-style-type: none"> <li>• Defective sensor in tray 2</li> <li>• Defective motor</li> <li>• Detective tray wires</li> </ul>
<b>SC31-40</b>	Master ROM error	Checksum error in the paper tray board	<ul style="list-style-type: none"> <li>• Defective master ROM</li> <li>• Defective paper tray board</li> </ul>
<b>SC31-41</b>	Master RAM error	Signal transmission error in the paper tray board	<ul style="list-style-type: none"> <li>• Defective paper tray board</li> </ul>
<b>SC31-50</b>	Slave ROM error	Checksum error in the paper tray board	<ul style="list-style-type: none"> <li>• Defective slave ROM</li> <li>• Defective paper tray board</li> </ul>
<b>SC31-51</b>	Slave RAM error	Signal transmission error in the paper tray board	<ul style="list-style-type: none"> <li>• Defective paper tray board</li> </ul>
<b>SC31-52</b>	Slave CPU error	The slave CPU is out of control.	<ul style="list-style-type: none"> <li>• Defective paper tray board</li> </ul>
<b>SC31-60</b>	Communication error	The master CPU does not communicate with the slave CPU	<ul style="list-style-type: none"> <li>• Defective paper tray board</li> </ul>
<b>SC41-00</b>	Side plate pulse generator sensor remains off	When the side plate in the delivery table moves, the sensor is not activated for more than 10 milliseconds after the side plate drive motor on signal is generated.	<ul style="list-style-type: none"> <li>• Defective motor</li> <li>• Defective sensor</li> <li>• Defective paper delivery table board</li> </ul>

<b>Code</b>	<b>Title</b>	<b>Conditions</b>	<b>Possible Causes</b>
<b>SC41-01</b>	Side plate home position sensor remains off	When the side plate in the delivery table moves, the sensor is not activated for more than 1,207 pulses after the side plate drive motor on signal is generated.	<ul style="list-style-type: none"> <li>• Defective motor</li> <li>• Defective sensor</li> <li>• Defective paper delivery table board</li> </ul>
<b>SC41-10</b>	End plate pulse generator sensor remains off	When the end plate in the delivery table moves, the sensor is not activated for more than 10 milliseconds after the end plate drive motor on signal is generated.	<ul style="list-style-type: none"> <li>• Defective motor</li> <li>• Defective sensor</li> <li>• Defective paper delivery table board</li> </ul>
<b>SC41-11</b>	End plate home position sensor remains off	When the end plate in the delivery table moves, the sensor is not de-activated for more than 2,379 pulses after the end plate drive motor on signal is generated.	<ul style="list-style-type: none"> <li>• Defective motor</li> <li>• Defective sensor</li> <li>• Defective paper delivery table board</li> </ul>
<b>SC45-00</b>	Relay transport switching motor lock	When the relay transport unit moves, the delivery table position and sort position sensors do not detect it for more than 2 seconds.	<ul style="list-style-type: none"> <li>• Relay transport switching motor</li> <li>• Delivery table position sensor</li> <li>• Sort position sensor</li> </ul>
<b>SC45-10</b>	Lower turn gate motor overrun - low	The turn gate unit overruns its lower limit, and the lower low turn gate limit switch turns on.	<ul style="list-style-type: none"> <li>• Lower low turn gate limit switch</li> <li>• Lower turn gate HP sensor</li> <li>• Lower turn gate motor</li> </ul>
<b>SC45-11</b>	Lower turn gate motor overrun - high	The turn gate unit overruns its upper limit, and the lower high turn gate limit switch turns on.	<ul style="list-style-type: none"> <li>• Lower high turn gate limit switch</li> <li>• Lower turn gate HP sensor</li> <li>• Lower turn gate motor</li> </ul>
<b>SC45-12</b>	Upper turn gate motor overrun - low	The turn gate unit overruns its lower limit, and the upper low turn gate switch turns on.	<ul style="list-style-type: none"> <li>• Upper low turn gate limit switch</li> <li>• Upper turn gate HP sensor</li> <li>• Upper turn gate motor</li> </ul>
<b>SC45-13</b>	Upper turn gate motor overrun - high	The turn gate unit overruns its upper limit, and the upper high turn gate switch turns on.	<ul style="list-style-type: none"> <li>• Upper high turn gate limit switch</li> <li>• Upper turn gate HP sensor</li> <li>• Upper turn gate motor</li> </ul>

 Service  
Tables

<b>Code</b>	<b>Title</b>	<b>Conditions</b>	<b>Possible Causes</b>
<b>SC45-20</b>	Lower side jogger lock	When the side jogger moves, it does not return for more than 4 seconds. When the side jogger moves from home position, the sensor does not de-activate for more than 2 seconds.	<ul style="list-style-type: none"> <li>• Lower side jogger HP sensor</li> <li>• Lower side jogger motor</li> </ul>
<b>SC45-21</b>	Lower end jogger lock	When the end jogger moves, it does not return for more than 4 seconds. When the end jogger moves from home position, the sensor does not de-activate for more than 2 seconds.	<ul style="list-style-type: none"> <li>• Lower end jogger HP sensor</li> <li>• Lower end jogger motor</li> </ul>
<b>SC45-22</b>	Upper side jogger lock	When the side jogger moves, it does not return for more than 4 seconds. When the side jogger moves from home position, the sensor does not de-activate for more than 2 seconds.	<ul style="list-style-type: none"> <li>• Upper side jogger HP sensor</li> <li>• Upper side jogger motor</li> </ul>
<b>SC45-23</b>	Lower end jogger lock	When the end jogger moves, it does not return for more than 4 seconds. When the end jogger moves from home position, the sensor does not de-activate for more than 2 seconds.	<ul style="list-style-type: none"> <li>• Upper end jogger HP sensor</li> <li>• Upper end jogger motor</li> </ul>
<b>SC45-30</b>	Lower turn gate motor lock	After the turn gate motor operates for 150 ms, there have been fewer than 100 encoder pulses from the motor.	<ul style="list-style-type: none"> <li>• Lower turn gate motor</li> <li>• MPU board</li> </ul>
<b>SC45-31</b>	Upper turn gate motor lock	After the turn gate motor operates for 150 ms, there have been fewer than 100 encoder pulses from the motor.	<ul style="list-style-type: none"> <li>• Upper turn gate motor</li> <li>• MPU board</li> </ul>

## 4.4 SPECIAL TOOLS

The following are the special tools used for service.

<b>Description</b>	<b>Part Number</b>	<b>Application</b>
Main Drive Securing Tool Kit (Drum securing tool and two positioning shafts as a set)	C229 9000	For main drive positioning
Scanner Positioning Pin Kit (4 pins as a set)	A006 9104	For scanner wire installation
Flash Memory Card	A230 9352	For updating firmware

## 4.5 SERVICE PROGRAM MODE

The service program (SP) mode is used to check electrical data, change modes, or change adjustment values.

### 4.5.1 ACCESS PROCEDURE

#### *Service Program Mode Access Procedure (For Engineers)*

1. Press the following keys on the operation panel in the following order:

**Clear Modes** ⇒ **1** ⇒ **0** ⇒ **7** ⇒ **Clear/Stop**

**Note:** Hold down the Clear/Stop key for more than 3 seconds.

2. The following is displayed on the LCD when the SP mode is accessed.

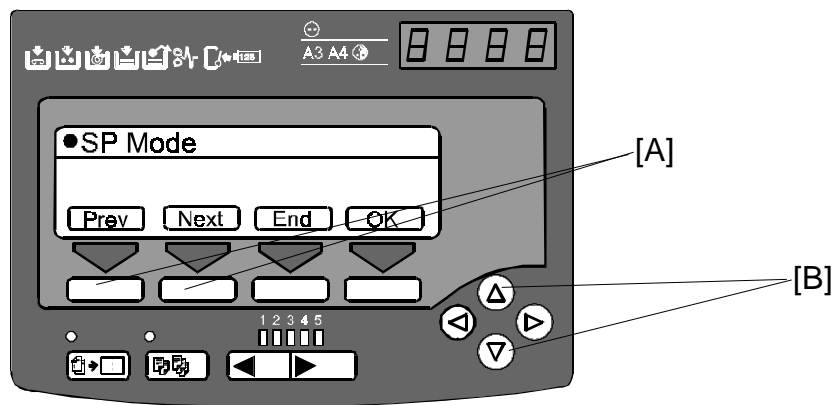

C235M500.WMF

3. Using the **number keys**, enter the desired **Main Menu Number** (listed below), then press the **OK** key on the bottom of the LCD (or the **Enter (#)** key).

**NOTE:** The number can also be shifted up or down by pressing the arrow keys [B] or the **Prev.** or **Next** key [A].

#### Main Menu Number List

1. Data Logging
2. Basic Settings
3. System Settings
4. Input Test Mode
5. Output Test Mode
6. System Adjustment
7. Memory Data Clear
8. System Test

- Using the **number keys**, enter the desired **Sub Menu Number** (listed in the service program table), then press the **OK** key on the bottom of the LCD (or the **Enter (#)** key).

**NOTE:** The number can also be shifted up or down by pressing the arrow keys [B] or the **Prev.** or **Next** key [A].

- Sub menu items have subordinate menus below them. Using the **number keys**, enter the desired **Menu Number** (listed in the service program table), then press the **OK** key on the bottom of the LCD (or the **Enter (#)** key).

**NOTE:** The number can also be shifted up or down by pressing the arrow keys [B] or the **Prev.** or **Next** key [A].

- Follow the "Change Adjustment Values or Modes" procedure below.

**NOTE:** To cancel the SP mode, press the **Clear Modes key** or the **Return** (or **End**) key at the bottom of the LCD.

### ***Change Adjustment Values or Modes***

- After entering the desired SP mode, press the **OK** key on the bottom of the LCD (or the **Enter (#)** key). The current value or mode will be displayed on the LCD (at the end of the second line).
- Enter the desired value or mode using the **number keys** (listed in the service program table).

**NOTE:** 1) Use the point ( . ) key to toggle between + and -.  
2) To enter a decimal place, you do not have to enter a decimal point.  
For example, to enter '1.5' just press '1' and '5' keys.

- Press the **OK** key to store the desired value or mode.
- To cancel the SP mode, press the **Clear Modes key** or the **Return** (or **End**) key on the bottom of the LCD.

### 4.5.1 SERVICE PROGRAM TABLE

#### Main Menu Number List

No.	Menu	Description
1	Data Logging	Various counters and logged data
2	Basic Settings	Various settings
3	System Settings	Settings used at installation
4	Input Test Mode	Sensor on/off status check
5	Output Test Mode	Motors and other components on/off check
6	System Adjustment	Various adjustments
7	Memory Data Clear	Resets or clears the SP mode data
8	System Test	Various data printouts and system tests

**NOTE:** 1) In this model, the User Tool settings cannot be accessed with SP mode.  
 2) The SP mode items for the optional units (such as the sorter) do not appear when the unit is not installed (e.g. SP 1-17).

#### 1. Data Logging

No.	Display	No.	Menu	Function
1-1	Master Counters	1	Total Master Counter	Total master counter.
		2	Total Master Counter - ADF	Master counter made in ADF mode.
1-2	Master Counters - Size	1	A3/DLT	Master counters for each original size used.  ‘-L’: Lengthwise feed
		2	B4/LG	
		3	A4-L/LT-L	
		4	A4/LT	
		5	B5-L	
		6	B5	
		7	Other Sizes	
1-3	Master Counter - Orig Type	1	Letter Mode	Master counters for each original type used.
		2	Letter/Photo Mode	
		3	Photo Mode	
		4	Pencil Mode	
		5	Tint Mode	
1-4	Master Counter - Ppr Type	1	Standard Paper	Master counters for each paper type used.
		2	Thick Paper	
		3	Thin Paper	
		4	Special	
		5	User 1	
		6	User 2	



No.	Display	No.	Menu	Function		
1-5	Master Counter - Copy Mode	1	Economy Mode	Master counters for various copy modes.		
		2	Combine 2			
		3	Combine 4			
		4	Memory Combine			
		5	Enlargement Mode			
		6	Reduction Mode			
		7	Zoom Mode			
		8	Directional Magnification			
		9	Auto Magnification			
		10	Make-up Mode			
		11	Make-up Mode-Photo			
		12	Margin Erase			
		13	Online Overlay			
		14	Overlay Mode			
		15	Format Overlay			
		16	Memory Overlay			
		17	Memory Combine			
		18	Date Stamp			
		19	Page Number			
		20	Default Stamp			
		21	Memory Original			
		22	Up/Down Shift			
		23	Side Shift			
		24	Short Master			
		25	Image Rotation			
		26	Same-No. Class			
		27	By-Class Class			
		28	Manual Class			
		29	Job Separator			
		30	Autocycle			
		33	Online Sort		For details, see the sorter service manual.	
		34	Sort			
		35	Class Sort			
		1-6	Master Counters - Sort	1	1-20 copies per Master	Master counters for sorter mode. For details, see the sorter service manual.
				2	21-40 copies per Master	
3	41-50 copies per Master					
4	51-80 copies per Master					
5	81- copies per Master					
1-7	Job Counters - Sort	1	1-5 masters per Job	Job counters for sorter mode. For details, see the sorter service manual.		
		2	6-10 masters per Job			
		3	11-20 masters per Job			
		4	21-30 masters per Job			
		5	31-50 masters per Job			
		6	51- masters per Job			

Service Tables

No.	Display	No.	Menu	Function
1-8	Print Counters	1	Total Print Counter	Total print counter.
		2	Print Counter-Color Drum	Print counter made with the optional color drum.
1-9	Print Counter - Size	1	Over A3/DLT	Print counters for each paper size used.  '-L': Lengthwise feed
		2	A3/DLT	
		3	B4/LG	
		4	A4-L/LT-L	
		5	A4/LT	
		6	B5-L	
		7	B5	
		8	A6-L	
		9	Under A6-L	
		10	Other Sizes	
1-10	Print Counters - Ppr Type	1	Standard Paper	Print counters for each paper type used.
		2	Thick Paper	
		3	Thin Paper	
		4	Special	
		5	User 1	
		6	User 2	
1-12	Print Counters - Sorter	1	Larger than A4	Print counters for sorter mode. For details, see the sorter service manual.
		2	A4 and Smaller	
		3	From Paper Table	
		4	From Tray 1 (Feed Station)	
		5	From Tray 2 (Feed Station)	
1-13	Copies Per Orig Counters	1	1 - 3 Prints	Copies-per-original counters.
		2	4 - 5 Prints	
		3	6 - 10 Prints	
		4	11 - 20 Prints	
		5	21 - 30 Prints	
		6	31 - 50 Prints	
		7	51 - 70 Prints	
		8	71 - 100 Prints	
		9	101 - 200 Prints	
		10	201 - 500 Prints	
		11	501 - 1000 Prints	
		12	Over 1000 Prints	
1-14	Counter/Jam Ratio	1	Master Set Error	Counters for various types of jams. Jam ratios are also displayed.
		2	Master Clamp Error	
		3	Master Cut Error	
		4	Master Eject ON Check	
		5	Pressure Plate Error	
		6	Master Eject OFF Check	
		7	Registration ON Check	
		8	Feed Timing ON Check	
		9	Feed Timing OFF Check	

No.	Display	No.	Menu	Function
1-14	Counter/Jam Ratio	10	Paper Upper Wrapping	Counters for various types of jams. Jam ratios are also displayed.
		11	Paper Lower Wrapping	
		12	Paper Exit OFF Check	
		13	DF Feed-in Error	
		14	DF Feed-out Error	
1-15	Feed-in/Reg Roller Jams	1	Jam P0 Standard	Feed-in jams and registration roller jams for various paper sizes and paper types.
		2	Jam P0 Thick	
		3	Jam P0 Thin	
		4	Jam P0 Others	
		5	Jam P1 Standard	Registration roller jams (when the paper feed timing sensor stays on) for various paper sizes and paper types.
		6	Jam P1 Thick	
		7	Jam P1 Thin	
		8	Jam P1 Others	
		9	Jam P2 Standard	Upper wrap, lower wrap, and feed-out jams for various paper sizes and paper types.
		10	Jam P2 Thick	
		11	Jam P2 Thin	
		12	Jam P2 Others	
1-17	Jam Counters - Sorter	1	Relay Transport section	Counters for various location jams in the sorter. For details, see the sorter service manual.
		2	Horizontal Trans. section	
		3	Vertical Trans. section	
		4	Lower 20 Bins section	
		5	Upper 20 Bins section	
1-18	Other Counters	1	Set Master Counter	
		2	Ejected Master Counter	
		3	Ink Pump Rotation Count	
		4	Master End Counter	
		5	Ink End Counter	
		6	Master Full Counter	
		7	Original Counter ADF	
		8	Original Counter Platen	
		9	Misfeed Setting Counter	Number of times the user changed the 'Misfeed' setting for paper feed or separation pressures.
		10	Multifeed Setting Count	Number of times the user changed the 'Multifeed' setting for paper feed or separation pressures.
		11	Start Error Message Cnt.	Number of times an error message appeared when the Start key was pressed.
		14	Open Counter Cover on Move	See the sorter service manual.

Service Tables

No.	Display	No.	Menu	Function
1-19	Machine Information	1	ROM Part Number	
		2	Serial Number	Use this to view the data input with SP 3-1-1.
		5	ROM Version	
		10	JS Sorter ROM Version	Displayed when the sorter is installed.
		11	Power On Time	
1-20	Service Information	1	Tel. Number for Service	Enter data with SP3-1-4 at installation if required.
		2	SC Counter	Displays the latest 20 records of the SC codes displayed. Use the arrow keys to view the records.
1-21	Sales Mode Check	1	Save Ink in Sorter Mode	Do not use (Japanese version use only).
		2	Japan Display Type	
		3	Swap Start Key	
		4	Ink Supply Pre-Printing	
		5	Set Job Separation	
		6	Set Key Counter	
		7	Set Key Card	
		8	Paper Delivery Table	
		9	Main Scan Position	
		10	Scan Start Position - DF	
		11	Scanning Speed	

**2. Basic Settings**

No.	Display	No.	Menu	Function	De- fault	Setting	
2-1	Default User Settings	1	Print Speed	See Note 1.	3	1 to 5	
		2	Default Image Position - Top/Bottom		0	-15.0 to 15.0 mm	
		3	Default Image Position Left/Right		0	-10.0 to 10.0 mm	
		4	Make-up Pattern1		See Note 2.	1	1 to 40
		5	Make-up Pattern2			1	1 to 40
		6	Make-up Pattern3			1	1 to 40
		7	Make-up Pattern4			1	1 to 40
2-2	Disable Sensors	1	Ink Detection	Enables/disables various sensors for test purposes.	ON	ON/OFF	
		2	Paper Length Detection		ON	ON/OFF	
		3	Paper Size Detection		ON	ON/OFF	
		4	Drum Master Detection		ON	ON/OFF	
		5	Platen Cover Set Detect		ON	ON/OFF	
		6	ADF Close Detection		ON	ON/OFF	
2-3	JS Sorter Settings	1	Set Unit	For details, refer to the sorter service manual.	U&L	U&L/Upper/Lower	
		2	Sort Number Limit		No	Yes/No	
		3	Ink Save Mode for Sorter		OFF	ON/OFF	
		4	1 Bin Capacity Limit		50	1 to 50	
		5	Interval Jogger Set - Sort		0	0 to 1	
		6	Interval Jogger Set - Class		0	0 to 1	
		7	Speed Setting		2	1 to 3	

Service Tables

No.	Display	No.	Menu	Function	De- fault	Setting
2-4	Destination Settings	1	Set Type by Code	By entering the machine code (e.g. for C235-17, input 235-17), the following values go to the factory settings for that model: * User tool 1-4 (mm/inch) * User tool 1-5 (language) * SP 2-4-3 * SP 2-4-4  [NOTE] 235-17: Ricoh North America 235-27: Ricoh Europe * Use the point ( . ) key to enter ‘-.’	-	-
		2	Display Type (for Japan)	Do not use.	0	0 to 2
		3	Drum Selection	See Note 3.	-	DLT/A3
		4	Machine Destination	See Note 4.	0	0: Other 1: Japan
2-5	T Head Energy Settings	1	Thermal Head Energy Temperature Control – Black Ink	See Note 5.	ON	ON/OFF
		2	Thermal Head Energy Temperature Control – Color Ink		ON	ON/OFF
		3	T Head Energy - Standard	Thermal head energy in standard and economy modes, as percentage of full power.	7	0 to 50%
		4	T Head Energy - Economy		13	0 to 43%
2-6	Other Settings	1	APS A5 Size Detection	See Note 6.	No	Yes/No
		2	Swap Start Key	See Note 7.	No	Yes/No
		3	Sharpen Image Mode	See Note 8.	0	0 to 2
		4	A3 Master 2 Count Up	See Note 9.	2	1 to 3
		5	Num of Matser Eject Trial	This specifies the number of master eject attempts before an error is indicated.	2	1 to 3
		6	Drum Idling	See Note 10.	OFF	ON/OFF
		7	Auto Master Save Select		Auto	Auto/OFF

No.	Display	No.	Menu	Function	De- fault	Setting
2-6	Other Settings	8	Ink Supply w/Trial Print	ON: Ink is supplied while a trial print is made after making a new master.	OFF	ON/OFF
		9	Ink Auxiliary Supply	See Note 11.	0	0 to 2

## Notes

### 1: 2-1-1 (Default print speed, cpm)

1: 60, 2: 75, 3: 90, 4: 105, 5: 120

### 2: 2-1-4 to -7 (Default make-up patterns 1 to 4)

0 to 39: Preset patterns, from 1 to 40  
40 to 43: User-created patterns A to D

### 3: 2-4-3 (Drum Size – A3 or DLT)

This setting changes the master making area. It also affects the available range for the default image position shift (top/bottom, SP2-1-2).

A3: -15 mm to + 15 mm  
DLT: -10 mm to + 10 mm

### 4: 2-4-4 (Machine Destination)

Always set this mode as 'Other.' If 'Japan' is selected, User Tools 6-10 that are not used for other versions is displayed.

### 5: 2-5-1 and -2 (Thermal head energy control with temperature)

If this is switched on, the energy supplied to the thermal head will depend on the temperature measured by the thermistor in the drum.

	Less than 18 °C	18 – 28 °C	More than 28 °C
Standard	SP 2-5-3 value (Default: -7%)	SP 2-5-3 – 5% (Default: -12%)	SP 2-5-3 – 10% (Default: -17%)
Economy	SP 2-5-4 value (Default: -25%)		

### 6: 2-6-1 (APS A5 Size Detection)

This determines how the machine behaves if the APS sensors cannot detect the original because it is too small.

0: No original detected, 1: A5 assumed

Default: 0

### 7: 2-6-2 (Swap Start Key)

Enables swapping *the Start (master making) key function* and *the Print key function* depending on the end user's preference. ('No' is the default setting.)

**8: 2-6-3 (Sharpen Image Mode)**

When this SP mode is on, fine details become more apparent in letter mode. But the edges of paper pasted onto the original might appear on the print.

**9: 2-6-4 (Double count-up for A3 masters)**

0: The counters go up by 1 only.

1: The master counter goes up by 2.

2: The master and print counters both go up by 2.

**10: 2-6-6 (Drum Idling)**

This mode has two options: "Fast" and "Slow". Fast is the default setting and is used with the new 16-kgf printing pressure setting. (See Pearl RTB No. 3 for more details about the new printing pressure setting.)

Fast mode skips the 30-rpm drum rotation speed at the beginning of printing. Consequently, the drum rotation speed increases as shown in the table below. Slow mode does not skip the 30-rpm drum rotation speed. Note that there are two cases depending on the temperature inside of the drum, detected by the thermistor. With the 'Slow' setting, paper wrapping jams become more likely unless the printing pressure is reduced to 14 kgf.

SP2-125 Setting	Drum Temperature	Trial Print	1st Print	2nd Print	3rd Print	4th Print	5th Print	6th Print	7th Print
Slow	Below 15 °C	16	16	<b>30</b>	60	75	90	105	120
	15 °C or above	16	<b>30</b>	60	75	90	105	120	120
Fast	Below 15 °C	16	16	60	75	90	105	120	120
	15 °C or above	16	60	75	90	105	120	120	120

\* These figures apply to the highest printing speed (120 rpm).

**11: 2-6-9 (Ink Auxiliary Supply)**

This mode determines when ink is detected and supplied. There are three possible settings.

- '0: After': Ink detection and supply are done when a print job finishes.
- '1: Before': They are done when the Print Start key is pressed (and before starting printing).
- '2: No': Ink is not added except during normal printing.

Note that if the machine detects a low ink condition during printing, ink is supplied regardless of this setting.

To minimize the wait time for drum idling, ink supply prior to starting printing has been eliminated by setting this mode to '0: After' as the default. With older firmware, when the Print Start key is pressed, the machine carries out the ink detection and (if low ink is detected) starts to supply ink before starting printing. (This ink detection is likely only when an operator cancels the Auto-cycle mode, which is selected by default. In the Auto-cycle mode, the machine enters the printing process without detecting the ink after making a master.)



**3. System Settings**

No	Display	No	Menu	Function	Default	Setting
3-1	Installation Settings	1	Serial Number	Use these to input the serial numbers, etc. Do these at installation if required. The data is used in the data printout mode in the system test. (SP3-1-1 can be seen in SP1-19. SP3-1-4 can be seen in SP1-20-1.)	-	
		4	Tel. Number for Service		-	
		5	Date		-	
		6	Installation Date		-	
		7	First Power On Date		-	
3-2	Unit Settings	1	Set Job Separation		Yes	No/Yes
		2	Set Key Counter	Set to Yes if installed.	No	No/Yes
		3	Set Key Card	Japan only	No	No/Yes
		4	Set Paper Delivery Table	Japan only	No	No/Yes
		5	Set Paper Feed Station	Japan only	No	No/Yes
		6	Set Sorter	Set to Yes if installed.	No	No/Yes

Service Tables

**4. Input Test Mode**

SP No.	Display	No.	Menu
4-1	Scanner Unit	1	Scanner HP Sensor
		2	Original Length SN 0
		3	Original Length SN 1
		4	Original Width SN 2
		5	Original Width SN 3
		6	Original Length SN 4
		7	Original Length SN 5
		8	Platen Cover Sensor
4-10	Master Making Unit	1	Master Unit Set Sensor
		2	Cutter HP Sensor
		3	Master Set Sensor
		4	Master End Sensor
		5	Master Edge Sensor
		6	Platen Release Sensor
		7	Thermal Head Temperature
4-20	Master Eject Unit	1	Eject Box Set Sensor
		2	Master Eject Sensor
		3	Pressure Plate HP Sensor
		4	Pressure Plate Limit SN
4-30	Paper Feed Table	1	Paper Table Lowering SW
		2	Table Lower Limit Sensor
		3	Paper Table Height SN
		4	Paper Table Set Sensor
4-31	Paper Feed Table-Paper	1	Paper End Sensor
		2	Paper Length Sensor
		3	Paper Width Detection 0
		4	Paper Width Detection 1
		5	Paper Width Detection 2
		6	Paper Width Detection 3
		7	Paper Width Detection 4
		8	Paper Width Detection 5
4-40	Paper Feed Pressure	1	Paper Feed Pressure 0
		2	Paper Feed Pressure 1
		3	Paper Feed Pressure 2
		4	Paper Feed Pressure 3
4-41	Separation Pressure	1	Separation Pressure 0
		2	Separation Pressure 1
		3	Separation Pressure 2
		4	Separation Pressure 3
4-42	Friction Pad	1	1st Friction Pad HP Sensor
		2	2nd Friction Pad HP Sensor
		3	Friction Pad Position - Normal
		4	Friction Pad Position - Special

SP No.	Display	No.	Menu
4-50	Paper Transport	1	Paper Registration SN
		2	Paper Feed Timing Sensor
		3	Paper Feed Start Sensor
		4	Tray Feed Start SN
		5	Lower Wrapping Jam SN
		6	Paper Exit Sensor
		7	P Cylinder Feed Encoder
		8	Wing Upper Position SN
		9	Wing Lower Position SN
4-60	Around the Drum	1	1st Drum Position Sensor
		2	2nd Drum Position Sensor
		3	3rd Drum Position Sensor
		4	Drum Type Check 0
		5	Drum Type Check 1
		6	1st Drum Master Sensor
		7	2nd Drum Master Sensor
		8	Clamp Close Position SN
		9	Clamper Open Position SN
		10	A3 Cam Sensor
		11	A4 Cam Sensor
4-61	Image/Drum Shift HP SN	1	Image Shift HP Sensor
		2	Drum Shift HP Sensor
4-62	Ink	1	Ink Pump Sensor
		2	Ink Cartridge Set Sensor
		3	Ink Detection
		4	Drum Idling Roller HP SN
		5	Ink Temperature
4-80	Other Sections	1	Front Door Open Detect
		2	Main Motor Lock Detect
		3	Relay Guide Set Sensor
4-90	Job Separator Unit	1	Slider Upper Limit SN
		2	Job Separator Paper SN
		3	Slider Position Sensor
		4	Slider HP Sensor
4-100	Document Feeder Unit	1	Installation Detect
		2	Cover Open Sensor
		3	Registration Sensor
		4	Original Rear Sensor
		5	Original Set Sensor
		6	Original Length SN 1
		7	Original Length SN 2
		8	Original Width SN 1
		9	Original Width SN 2
		10	Position Sensor

Service  
Tables

<b>SP No.</b>	<b>Display</b>	<b>No.</b>	<b>Menu</b>
4-110	Paper Delivery Table	1	Delivery Table Paper SN
		2	Side Plate Set Sensor
		3	Side Plate Pulse Sensor
		4	Side Plate HP Sensor
		5	End Plate Set Sensor
		6	End Plate Pulse Sensor
		7	End Plate HP Sensor
4-130	JS Sorter	1	Lower Bin SN
		2	Lower Entry SN
		3	Upper Bin SN
		4	Upper Entry SN
		5	Relay Paper SN
		6	Horizontal Paper SN
		7	Delivery Table Position SN
		8	Sort Position SN
		9	Lower Side Jogger HP SN
		10	Upper Side Jogger HP SN
		11	Lower End Jogger HP SN
		12	Upper End Jogger HP SN
		13	Lower Turn Gate Limit SW
		14	Upper Turn Gate Limit SW
		15	Lower Turn Gate Paper SN
		16	Upper Turn Gate Paper SN
		17	Lower Door Safety SW
		18	Upper Door Safety SW
		19	Delivery Table Set SW
		20	Vert. Cover Safety SW
		21	Horiz. Cover Safety SW
		22	Stapler Cover Safety SW
		23	Lower Bins Operation SW
		24	Upper Bins Operation SW
		25	Not used
		26	Not used
		27	Not used
		28	Not used
4-140	Options	1	Key Counter Detection
		2	Key Card Detection
		3	Not used

**5. Output Test Mode**

SP No.	Display	No.	Menu
5-001	Scanner Unit	1	Xenon Lamp
		2	Move Scanner - Scan
		3	Move Scanner - Return
		4	Move Scanner to HP
5-010	Master Making Unit	1	Master Feed Clutch
		2	Platen Release Motor
		3	Master Feed Motor
		4	Cutter Motor Forward
		5	Cutter Motor Reverse
		6	Move Cutter to HP
		7	Master Vacuum Fan
		8	Master Duct Entrance Sol
		9	Thermal Head ON
5-020	Master Eject Unit	1	M Eject Motor Forward
		2	M Eject Motor Reverse
		3	Pressure Plate to Limit
		4	Press Plate to Eject Pos
		5	Pressure Plate to HP
5-030	Paper Feed Table	1	Paper Table Motor Up
		2	Paper Table Motor Down
5-040	Paper Pressure Motor	1	Paper Pressure Motor Up
		2	Paper Press Motor Down
		3	Paper Pressure Min
		4	Paper Pressure 1
		5	Paper Pressure 2
		6	Paper Pressure 3
		7	Paper Pressure 4
		8	Paper Pressure 5
		9	Paper Pressure Max
5-041	Separation Pressure Motor	1	Motor Up
		2	Motor Down
		3	Eject Position
		4	Separation Pressure Min
		5	Separation Pressure 1
		6	Separation Pressure 2
		7	Separation Pressure 3
		8	Separation Pressure 4
		9	Separation Pressure 5
		10	Separation Pressure Max
5-042	Friction Pad Motor	1	Standard
		2	Special

Service  
Tables

SP No.	Display	No.	Menu
5-050	Paper Feed Motor	1	Slowest
		2	30 rpm
		3	1st Speed
		4	2nd Speed
		5	3rd Speed
		6	4th Speed
		7	5th Speed
5-051	Registration Motor	1	Slowest
		2	30 rpm
		3	1st Speed
		4	2nd Speed
		5	3rd Speed
		6	4th Speed
		7	5th Speed
5-052	Paper Delivery	1	Wing Guide Motor Up
		2	Wing Guide Motor Down
		3	Air Knife Fan
		4	Transport Vacuum Fan
5-060	Drum Rotation	1	Slowest
		2	1st Speed
		3	2nd Speed
		4	3rd Speed
		5	4th Speed
		6	5th Speed
5-061	Clamper Motor	1	Clamper Motor - Open
		2	Clamper Motor - Close
5-062	Image Shift Motor	1	Image Shift Motor - ←
		2	Image Shift Motor - →
		3	Drum Shift Motor - ↑
		4	Drum Shift Motor - ↓
5-063	Drum Idling Roller	1	Drum Idling Roller ON
		2	Idling Roller Return
5-064	Around the Drum	1	Ink Pump Motor
		2	Printing Pressure Sol.
		3	Shift Pressure Cam to A3
		4	Shift Pressure Cam to A4
		5	3rd Drum Position LED - GREEN
		6	3rd Drum Position LED - RED
5-070	Counters	1	Print Counter Up
		2	Master Counter Up
5-080	Other Sections - Main Body	1	All Indicators On
		2	PSU Fan Motor
5-090	Job Separator Unit	1	Slider Lift Motor - Up
		2	Slider Lift Motor - Down
		3	Job Separator Motor - Forward

SP No.	Display	No.	Menu
5-090	Job Separator Unit	4	Job Separator Motor - Reverse
5-100	Document Feeder Unit	1	Feed Motor
		2	Feed Clutch
		3	Pick-up Solenoid
5-110	Paper Delivery Table	1	Side Plate-Extension
		2	Side Plate-Retracton
		3	End Plate-Retracton
		4	End Plate-Extension
5-120	Paper Feed Station	1	R-Tray1 Lift Motor: Up
		2	R-Tray1 Lift Motor: Down
		3	Tray1 Right Lock Sol.
		4	Tray1 Friction Pad Sol.
		5	Tray1 Connection Sol.
		6	L-Tray1 Lift Motor: Up
		7	L-Tray1 Lift Motor: Down
		8	Tray1 Left Lock Sol.
		9	Back Plate - Right
		10	Back Plate - Left
		11	Tray2 Lift Motor: Up
		12	Tray2 Lift Motor: Down
		13	Tray 2 Lock Sol.
		14	Tray2 Friction Pad Sol.
		15	Tray Feed Motor - Forward
		16	Tray Feed Motor - Reverse
		17	Tray Registration Motor
		18	Tray2 Feed Clutch
		19	Tray Relay Clutch
		20	Tray Exit Clutch
5-130	JS Sorter	1	Lower Turn Gate Mtr Upt
		2	Lower Turn Gate Mtr Down
		3	Upper Turn Gate Mtr Up
		4	Upper Turn Gate Mtr Down
		5	Relay Transport Motor
		6	Horizontal Transport Mtr
		7	Lower Vert. Transport Mtr
		8	Upper Vert. Transport Mtr
		9	Relay Switching Mtr To Sort
		10	Relay Switching Mtr To Non
		11	Lower S-Jogger Forward
		12	Lower S-Jogger Reverse
		13	Upper S-Jogger Forward
		14	Upper S-Jogger Reverse
		15	Lower E-Jogger Forward
		16	Lower E-Jogger Reverse
		17	Upper E-Jogger Forward

Service Tables

<b>SP No.</b>	<b>Display</b>	<b>No.</b>	<b>Menu</b>
5-130	JS Sorter	18	Upper E-Jogger Reverse
		19	Not used
		20	Not used
		21	Relay Trans. Fan Mtr
		22	Horz. Trans. Fan1 Mtr
		23	Horz. Trans. Fan2 Mtr
		24	Lower Vrt Trans. Fan1 Mtr
		25	Lower Vrt Trans. Fan2 Mtr
		26	Upper Vrt Trans. Fan1 Mtr
		27	Upper Vrt Trans. Fan2 Mtr
		28	Wing Guide Solenoid
		29	Delivery Table Lock SOL
		30	Lower Turn Gate SOL
		31	Upper Turn Gate SOL
32	Sorter Free Run		
5-140	Options	1	Count-up Key Counter
		2	Count-up Key Card
		4	Not used



**6. System Adjustment**

No.	Display	No.	Menu	Function	Default	Setting
6-1	Scan&Writing	1	Main Scan Pos. - Platen	Side-to-side registration adjustment; see Note 1.	0	-5.0 to 2.0 mm
		2	Main Scan Position - DF		0	-5.0 to 5.0 mm
		3	Scan Start Pos. - Platen	Scanning start line adjustment; see Note 2.	0	-2.0 to 5.0 mm
		4	Scan Start Position - DF		0	-5.0 to 5.0 mm
		5	Scanning Speed - Platen	See Note 3.	0	-5.0 to 5.0%
		6	Scanning Speed - DF		0	-5.0 to 5.0%
		7	Master Writing Speed	See Note 4.	0	-5.0 to 5.0%
		8	Master Writing Length	Do not use in the field.	0	-5.0 to 5.0%
		9	Master Main Scan Pos		0	-3.0 to 3.0 mm
6-2	Master Making Density	1	Master Making Density	See Note 5.	1	0 to 2
		2	Master Making Density - Letter/Photo		1	0 to 2
6-3	Drum Master Clamp	1	Drum Master Clamp Regist	See Note 6.	0	-10 to 10 mm
6-4	SN Voltages/Thresholds	1	Master Eject Sensor	The use of these SP modes is explained in various parts of the Replacement and Adjustment section.	2.5	1.5 to 3.0 V
		2	Drum Master 1 Sensor		2.5	1.5 to 3.0 V
		3	Drum Master 2 Sensor		2.5	1.5 to 3.0 V
		4	Master End Sensor		0.8	0.5 to 3.0 V
		5	Paper Exit Sensor		2.0	1.5 to 3.0 V
		6	Master Edge Sensor		2.0	1.5 to 3.0 V
6-5	Sensor Board Unit	1	SBU Auto Calibration	Refer to the Replacements and Adjustments section.	-	-
		2	SBU Gain Setting-EVEN	Do not adjust.	-	0 to 255
		3	SBU Gain Setting-ODD	Do not adjust.	-	0 to 255
		4	SBU DC Count Setting-EVEN	Do not adjust.	-	0 to 255
		5	SBU DC Count Setting-ODD	Do not adjust.	-	0 to 255

No.	Display	No.	Menu	Function	Default	Setting
6-5	Sensor Board Unit	6	SBU Reference Value	Do not adjust.	-	0 to 255
		7	SBU Offset Value-EVEN	Do not adjust.	-	0 to 255
		8	SBU Offset Value-ODD	Do not adjust.	-	0 to 255
6-6	MTF Filters	1	Letter Mode-Main Scan	See Note 7.	2	0 to 7
		2	Letter Mode-Sub Scan		1	0 to 7
		3	LetterPhoto Mode-Main Scan		0	0 to 7
		4	Letter/Photo Mode-Sub Scan		0	0 to 7
		5	Photo Mode-Main Scan		4	0 to 7
		6	Photo Mode-Sub Scan		4	0 to 7
		7	Pencil Mode-Main Scan		2	0 to 7
		8	Pencil Mode-Sub Scan		1	0 to 7
		9	Tint Mode-Main Scan		4	0 to 7
		10	Tint Mode-Sub Scan		4	0 to 7
6-9	Paper Feed Pressure	1	FeedPressure Std Nor Ppr	See Note 8.	3	0 to 6
		2	Freq - Normal Paper		5	0 to 6
		3	V Freq - Normal Paper		6	0 to 6
		4	FeedPressure Std Thick		3	0 to 6
		5	Freq - Thick Paper		5	0 to 6
		6	V Freq - Thick Paper		6	0 to 6
		7	Feed Pressure Std Thin		1	0 to 6
		8	Freq - Thin Paper		3	0 to 6
		9	V Freq - Thin Paper		5	0 to 6
		10	FeedPressure Std Special		1	0 to 6
		11	Freq - Special Paper		3	0 to 6

No.	Display	No.	Menu	Function	Default	Setting
6-9	Paper Feed Pressure	12	V Freq - Special Paper	See Note 8.	5	0 to 6
		13	Feed Pressure Std User 1		5	0 to 6
		14	Freq - User 1 Paper		6	0 to 6
		15	V Freq - User 1 Paper		6	0 to 6
		16	Feed Pressure Std User 2		5	0 to 6
		17	Freq - User 2 Paper		6	0 to 6
		18	V Freq - User 2 Paper		6	0 to 6
6-10	Separation Pressure	1	SepPressure Std Nor Ppr	See Note 8.	4	0 to 6
		2	Freq - Normal Paper		5	0 to 6
		3	V Freq - Normal Paper		6	0 to 6
		4	SepPressure Std Thick		2	0 to 6
		5	Freq - Thick Paper		4	0 to 6
		6	V Freq - Thick Paper		6	0 to 6
		7	Sep Pressure Std Thin		4	0 to 6
		8	Freq - Thin Paper		5	0 to 6
		9	V Freq - Thin Paper		6	0 to 6
		10	SepPressure Std Special		1	0 to 6
		11	Freq - Special Paper		3	0 to 6
		12	V Freq - Special Paper		5	0 to 6
		13	SepPressure Std User 1		2	0 to 6
		14	Freq - User 1 Paper		4	0 to 6
		15	V Freq - User 1 Paper		6	0 to 6
		16	SepPressure Std User 2		2	0 to 6
		17	Freq - User 2 Paper		4	0 to 6

Service Tables

No.	Display	No.	Menu	Function	Default	Setting
6-10	Separation Pressure	18	V Freq - User 2 Paper	See Note 8.	6	0 to 6
6-11	Friction Pad	1	Normal Paper	See Note 9.	Normal	Normal/Special
		2	Thick Paper		Special	Normal/Special
		3	Thin Paper		Special	Normal/Special
		4	Special Paper		Special	Normal/Special
		5	User1 Paper		Normal	Normal/Special
		6	User2 Paper		Normal	Normal/Special
6-12	Paper Clamping	1	Normal Paper	See Note 10.	Enable	Enable/OFF
		2	Thick Paper		Enable	Enable/OFF
		3	Thin Paper		Enable	Enable/OFF
		4	Special Paper		Enable	Enable/OFF
		5	User1 Paper		Enable	Enable/OFF
		6	User2 Paper		Enable	Enable/OFF
6-13	Delivery Wing Angle	1	Normal Paper	See Note 11.	High	High/Low
		2	Thick Paper		Low	High/Low
		3	Thin Paper		High	High/Low
		4	Special Paper		Low	High/Low
		5	User1 Paper		High	High/Low
		6	User2 Paper		Low	High/Low
6-14	Paper Feed Delay	1	16 rpm	Do not adjust. (Changes the feed motor on timing after the feed start timing sensor is activated.)	199	0 to 255
		2	20 rpm		200	0 to 255
		3	30 rpm		200	0 to 255
		4	60 rpm		219	0 to 255
		5	75 rpm		147	0 to 255
		6	90 rpm		100	0 to 255
		7	105 rpm		53	0 to 255
		8	120 rpm		26	0 to 255
6-15	Paper Feed Delay-Thick	1	16 rpm	Do not adjust. (Changes the feed motor on timing in thick and special paper modes after the feed start timing sensor is activated.)	199	0 to 255
		2	20 rpm		200	0 to 255
		3	30 rpm		200	0 to 255
		4	60 rpm		219	0 to 255
		5	75 rpm		147	0 to 255
		6	90 rpm		100	0 to 255

No.	Display	No.	Menu	Function	Default	Setting
6-15	Paper Feed Delay-Thick	7	105 rpm	Do not adjust. (Changes the feed motor on timing in thick and special paper modes after the feed start timing sensor is activated.)	53	0 to 255
		8	120 rpm		26	0 to 255
6-16	Regist Delay	1	16 rpm	Do not adjust. (Changes the registration motor on timing after the feed start timing sensor is activated.)	35	0 to 255
		2	20 rpm		35	0 to 255
		3	30 rpm		35	0 to 255
		4	60 rpm		32	0 to 255
		5	75 rpm		30	0 to 255
		6	90 rpm		26	0 to 255
		7	105 rpm		21	0 to 255
		8	120 rpm		15	0 to 255
6-17	Regist Delay - Thick	1	16 rpm	Do not adjust. (Changes the registration motor on timing in thick paper mode after the feed start timing sensor is activated.)	35	0 to 255
		2	20 rpm		35	0 to 255
		3	30 rpm		35	0 to 255
		4	60 rpm		33	0 to 255
		5	75 rpm		31	0 to 255
		6	90 rpm		27	0 to 255
		7	105 rpm		22	0 to 255
		8	120 rpm		16	0 to 255
6-18	Regist Delay - Special	1	16 rpm	Do not adjust. (Changes the registration motor on timing in special paper mode after the feed start timing sensor is activated.)	35	0 to 255
		2	20 rpm		35	0 to 255
		3	30 rpm		35	0 to 255
		4	60 rpm		33	0 to 255
		5	75 rpm		31	0 to 255
		6	90 rpm		27	0 to 255
		7	105 rpm		22	0 to 255
		8	120 rpm		16	0 to 255
6-19	A4 Regist Delay	1	16 rpm	Do not adjust. (Changes the registration motor on timing in the use of the A4 drum after the feed start timing sensor is activated.)	35	0 to 255
		2	20 rpm		35	0 to 255
		3	30 rpm		35	0 to 255
		4	60 rpm		32	0 to 255
		5	75 rpm		30	0 to 255
		6	90 rpm		25	0 to 255
		7	105 rpm		20	0 to 255
		8	120 rpm		14	0 to 255
6-20	A4 Regist Delay - Thick	1	16 rpm	Do not adjust. (Changes the registration motor on timing in thick paper mode in combination with the use of the A4 drum after the feed start timing sensor is activated.)	35	0 to 255
		2	20 rpm		35	0 to 255
		3	30 rpm		35	0 to 255
		4	60 rpm		33	0 to 255
		5	75 rpm		31	0 to 255
		6	90 rpm		26	0 to 255
		7	105 rpm		21	0 to 255
		8	120 rpm		14	0 to 255

No.	Display	No.	Menu	Function	Default	Setting
6-21	Skip Regist Delay	1	16 rpm	Do not adjust. (Changes the registration motor on timing (when using the skip feed mode) after the feed start sensor is activated.)	35	0 to 255
		2	20 rpm		35	0 to 255
		3	30 rpm		35	0 to 255
		4	60 rpm		32	0 to 255
		5	75 rpm		30	0 to 255
		6	90 rpm		25	0 to 255
		7	105 rpm		21	0 to 255
		8	120 rpm		14	0 to 255
6-22	A4 Skip Regist Delay	1	16 rpm	Do not adjust. (Changes the registration motor on timing in the use of the A4 drum after the feed start timing sensor is activated.)	35	0 to 255
		2	20 rpm		35	0 to 255
		3	30 rpm		35	0 to 255
		4	60 rpm		32	0 to 255
		5	75 rpm		30	0 to 255
		6	90 rpm		25	0 to 255
		7	105 rpm		20	0 to 255
		8	120 rpm		14	0 to 255
6-23	Paper Clamp Timing	1	Paper Clamp Timing Pulse	See Replacements and Adjustments – Paper Feed Length Adjustment for how to use.	197	0 to 255
		2	Paper Clamp-Thick Paper		200	0 to 255
		3	Paper Clamp - A4 Cam	Do not adjust.	197	0 to 255
		4	Feed Timing Pulse	Do not adjust.	163	0 to 255
		5	Feed Stop Timing Pulse	See Replacements and Adjustments – Paper Feed Length Adjustment for how to use.	25	0 to 255
		6	Print Position2 Setting	Do not adjust.	103	0 to 255
		7	Print Position1 Setting	Do not adjust.	140	0 to 255
6-24	PaperClampTiming - Special	1	Paper Clamp Timing Pulse	See Replacements and Adjustments – Paper Feed Length Adjustment for how to use.	197	0 to 255
		2	Thick Paper		200	0 to 255
		3	A4 Cam	Do not adjust.	197	0 to 255
6-25	Paper Clamp Timing-User1	1	Paper Clamp Timing Pulse	See Replacements and Adjustments – Paper Feed Length Adjustment for how to use.	197	0 to 255
		2	Feed Stop Timing Pulse		200	0 to 255
		3	A4 Cam	Do not adjust.	197	0 to 255
		4	Paper Feed Station		25	0 to 255

No.	Display	No.	Menu	Function	Default	Setting
6-26	Paper Clamp Timing-User2	1	Paper Clamp Timing Pulse	See Replacements and Adjustments – Paper Feed Length Adjustment for how to use.	197	0 to 255
		2	Feed Stop Timing Pulse		200	0 to 255
		3	A4 Cam		197	0 to 255
		4	Paper Feed Station		25	0 to 255
6-27	Regist Roller Speed	1	Standard	See Note 12.	High	High/Low
		2	Thick		Low	High/Low
		3	Thin		High	High/Low
		4	Special		Low	High/Low
		5	User 1		High	High/Low
		6	User 2		High	High/Low
6-40	JS Sorter	1	Move Jogger - Sideways	For details, refer to the sorter service manual.	0	-10 to 10 (-5.0 to +5.0 in 0.5 mm steps)
		2	Move Jogger - Lengthwise		0	Ditto
		3	Feed Speed 1st		0	50 to 100 rpm
		4	Feed Speed 2nd		0	50 to 100 rpm
		5	Feed Speed 3rd		0	50 to 100 rpm
		6	Feed Speed 4th		0	50 to 100 rpm
		7	Feed Speed 5th		0	50 to 100 rpm
		8	Timing Delay A3		0	-10 to 10 (-5.0 to +5.0 in 0.5 mm steps)
		9	Timing Delay B4 Sideways		0	Ditto
		10	Timing Delay A4 Sideways		0	Ditto
		11	Timing Delay A4 Lengthwise		0	Ditto
		12	Timing Delay B5 Sideways		0	Ditto
		13	Timing Delay DLT Sideways		0	Ditto
		14	Timing Delay LG Sideways		0	Ditto
		15	Timing Delay LT Sideways		0	Ditto

Service Tables

No.	Display	No.	Menu	Function	Default	Setting
6-40	JS Sorter	16	Timing Delay LT Lengthwise	For details, refer to the sorter service manual.	0	Ditto
		17	Timing Delay F Sideways		0	Ditto

### **Notes**

#### **1: 6-1-1 and -2 (Main scan position)**

Inputting a positive number moves the image away from the operation panel side of the machine. Use the point ( . ) key to switch between + and –.

#### **2: 6-1-3 and -4 (Scan start position)**

Inputting a positive number moves the image away from the leading edge of the printer paper. Use the point ( . ) key to switch between + and –.

#### **3: 6-1-5 and -6 (Scanning speed)**

Inputting a positive value stretches the image on the master. Inputting a negative value shrinks it. Use the point ( . ) key to switch between + and –.



**4: 6-1-7 (Master writing speed)**

This changes the master feed motor speed.

Inputting a positive value stretches the image on the master. Inputting a negative value shrinks it. Use the point ( . ) key to switch between + and –.

Normally, do not use this SP mode to adjust the vertical magnification. Use it only if the vertical magnification is not satisfactory by adjusting Scanning Speed (SP6-1-5 and -6).

**5: 6-2-1 (Master making density)**

0: Pale, 1: Normal, 2: Dark

The default is 1: Normal. Changing this moves the user's image density settings up or down one notch.

**6: 6-3-1 (Drum master clamper registration)**

This determines how far after the leading edge the master is clamped.

A larger value clamps the master further away from the leading edge, and moves the image closer to the leading edge of the paper.

Do not use this SP to adjust leading edge registration. Use SP6-1-3 and -4 for that.

**7: 6-6 (MTF filters)**

A stronger filter leads to a sharper image, but moiré can become more apparent.

Refer to the following table for the relationship between this SP mode value and filter strength (the relationship is not linear).

Value	Strength of Filter
7	X 4
6	X 2
0	X 1
5	X 1/2
4	X 1/4
3	X 1/8
2	X 1/16
1	X 1/32

**8: 6-9 and -10 (Paper feed and separation pressures for different paper types)**

These SP modes determine the paper feed and separation pressures that are automatically applied during paper feed. The user adjusts these pressures by selecting a paper type (normal, thick, thin, special, user 1, user 2), and then by selecting how often non-feeds and double feeds are occurring.

The user customizes the user 1 and user 2 types. These choices can be seen in the description for User Tools 4-19. Each of these choices has a set of feed and separation pressures (refer to Detailed Section Descriptions – Paper Feed).

- 6-9-1 to -3: Normal paper, feed pressure
- 6-9-4 to -6: Thick paper, feed pressure
- 6-9-7 to -9: Thin paper, feed pressure
- 6-9-10 to -12: Special paper, feed pressure
- 6-9-13 to -15: User 1 paper, feed pressure
- 6-9-16 to -18: User 2 paper, feed pressure
- 6-10-1 to -3: Normal paper, separation pressure
- 6-10-4 to -6: Thick paper, separation pressure
- 6-10-7 to -9: Thin paper, separation pressure
- 6-10-10 to -12: Special paper, separation pressure
- 6-10-13 to -15: User 1 paper, separation pressure
- 6-10-16 to -18: User 2 paper, separation pressure

The settings for user 1 and user 2 depend on the type of paper that the user has set these up for in User Tools 4-19.

**9: 6-11 (Friction pad)**

The machine switches the friction pads depending on the paper type selected by the user (standard, special, thick, user 1, user 2).

**10: 6-12 (Paper clamping)**

Whether the machine clamps the paper or not depends on the paper type selected by the user (standard, special, thick, user 1, user 2).

The settings for user 1 and user 2 depend on the type of paper that the user has set these up for in User Tools 4-19.

**11: 6-13 (Paper delivery table wing angle)**

The machine lifts or lowers the wings depending on the paper type selected by the user (standard, special, thick, user 1, user 2).

The settings for user 1 and user 2 depend on the type of paper that the user has set these up for in User Tools 4-19.

**12: 6-27 (Regist roller speed)**

For an accurate paper registration, the machine lowers the registration roller rotation speed depending on the paper type selected by the user (standard, special, thick, user 1, user 2). Usually, the 'high' speed setting (3% higher than the low) results in the better registration. However, when thick paper is used, it should be lowered because thick paper strongly pushes the paper clamber. This causes a friction to the smooth rotation of the pressure cylinder due to a play in the cylinder's drive transmission.

The settings for user 1 and user 2 depend on the type of paper that the user has set these up for in User Tools 4-19.

**7. Memory Data Clear**

SP No.	Display	No.	Menu
7-1	Memory Clear	1	Factory Settings
		2	User Custom Default
		3	User Program
		4	Make-up Pattern
		5	Reset Sales Mode Flags
7-2	Counter Clear	1	Total Print
		2	Jam/Error Logging
7-3	Code Clear	1	User Code
		2	Key Operator Code
7-4	Reset Paper Feed Systems	1	Feed Pressure
		2	Separation Pressure
		3	Friction Pad Settings
		4	Wing Guide Angle
		5	Feed Control Data
		6	Feed Control Pulse
7-5	Reset Image Adjustments	1	MTF Filter Settings
7-6	Reset Option Settings	1	JS Sorter Settings

**Notes****1: 7-1-1 to -2 (Memory Clear)**

See section 4.5.2 "Clearing the factory settings (SP7-1)".

**2: 7-1-5 (Reset Sales Mode Flags)**

Do not use. Japanese version use only.

**3: 7-4-5 (Feed Control Data)**

The following are reset to the default settings with SP7-4-5.

- SP6-14 (Paper Feed Delay)
- SP6-15 (Paper Feed Delay-Thick)
- SP6-16 (Regist Delay)
- SP6-17 (Regist Delay-Thick)
- SP6-18 (Regist Delay-Special)
- SP6-19 (A4 Regist Delay)
- SP6-20 (A4 Regist Delay-Thick)
- SP6-21 (Skip Regist Delay)
- SP6-22 (A4 Skip Regist Delay)

**4: 7-4-6 (Feed Control Pulse)**

The following are reset to the default settings with SP7-4-6.

- SP6-23 (Paper Clamp Timing)
- SP6-24 (Paper Clamp Timing-Special)
- SP6-25 (Paper Clamp Timing-User1)
- SP6-26 (Paper Clamp Timing-User2)

**8. System Test**

SP No.	Display	No.	Menu	Setting
8-1	Data Printout	1	All Logging Data	-
		2	User Code Counters Only	-
		3	Jam Counters Only	-
		4	SC Counters Only	-
		5	Jams/Errors Details	-
		6	User's Items Only	-
		7	User Tools-Standard	-
		8	User Tools-Class	-
		9	Basic Settings Printout	-
		10	Input Test Item Printout	-
		11	Output Test Item Printout	-
		12	All System Adjustment	-
		13	Paper Feed Adjustments	-
		14	Option Adjustment Print	-
8-2	Download Program	1	Load Program	-
		2	Load Program - Program Data	-
		3	Load Program - Font Data	-
		4	Load Program - Except M orig	-
8-3	Upload Program	1	Upload Program	-
8-5	TH Test Patterns	1	TH Test Patterns	0: Grid 1: Vertical 2: Horiz grey 3: Vert grey 4: 16 greys 5: Cross 6: Diag grid 7: 256 greys 8: 64 greys
		2	Master Makeup Pattern	1 to 40
8-6	Free Run - Scanner/ADF	1	Scanner Free Run/Mag.	50 to 200%
		2	ADF Free Run/Mag.	50 to 200%
8-7	Other Tests	1	APS Sensor Check Mode	-
		2	Not used	-

Service  
Tables**Notes****1: 8-2-1 (Load Program)**

This upgrades all the firmware using a flash memory card.

**NOTE:** This deletes all user data such as stored images.

**2: 8-2-2 (Load Program-Program Data)**

This upgrades the program area data in the firmware using a flash memory card.

**3: 8-2-3 (Load Program-Font Data)**

This upgrades the font data in the firmware using a flash memory card.

**4: 8-2-4 (Load Program-Except M Orig)**

This upgrades all data in the firmware except user area data using a flash memory card.

It is better to use this SP mode when upgrading the firmware.

See section "4.5.3 Load Program (SP8-2)".

## 4.5.2 CLEARING THE FACTORY SETTINGS (SP7-1)

### CAUTION

Performing "Clear factory settings" (SP7-1) resets a part of the settings stored in the RAM to their default settings. Normally, this SP mode should not be used. This procedure is required only after replacing the RAM on the MPU or when the machine malfunctions due to a damaged RAM.

**NOTE:** 3) The following are not reset or cleared even after doing "Clear factory settings" (SP7-1-1).

- SP 2-4: All destination settings
- SP 3-1-1: Serial number
- SP 3-1-5: Date
- SP 6- All :All system adjustment settings
- User Tools 1-5: Select Language on LCD

4) The following are reset to the default settings with "Clear user code counters only" (SP7-1-2).

- SP 2-1: All default user settings
- User Tools 3-1: Paper type
- User Tools 3-2: Image density level
- User Tools 3-3: Original mode
- User Tools 3-8: Contrast level for Photo mode
- User Tools 3-9: Screen image for Photo mode
- User Tools 3-12: Magnification ratio
- User Tools 4-1: Auto cycle On/Off

1. Print lists of SP data in order to restore the settings later.

**NOTE:** All system parameter lists can be printed using SP8-1.

2. Select an item from the SP7-1 menu.

3. Press the Enter (#) key while holding the "0" key.

**NOTE:** When the sequence is successful, "Cleared" is displayed.

### 4.5.3 LOAD PROGRAM (SP8-2)

The firmware in the flash ROM on the MPU can be upgraded using a flash memory card, as follows.

**NOTE:** Using SP8-3, the current firmware in the MPU can be uploaded to a flash memory card.

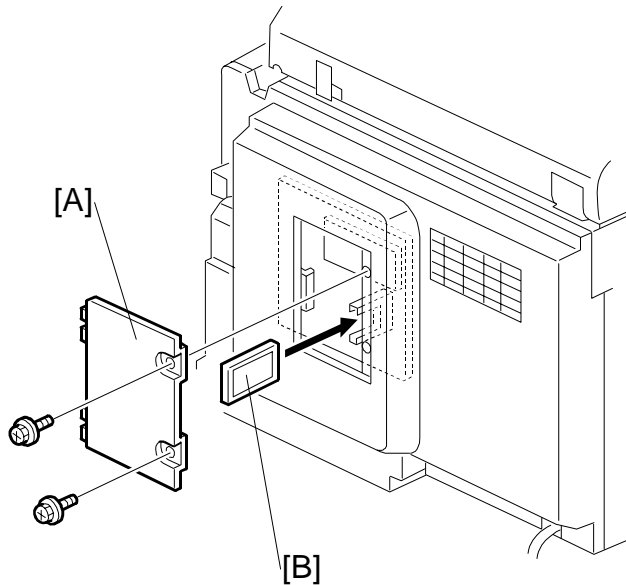

C235D014.WMF

1. Before downloading new software, check the current version with SP1-19-5.
2. Turn off the main switch and disconnect the power plug.
3. Remove the cover [A].
4. Plug the flash memory card [B] into the connector on the MPU.
5. Connect the power plug and turn on the main switch.
6. Access SP8-2-4 and press the **OK** key. Press the **Enter (#)** key to start downloading (the LCD displays '**Processing**').
7. After completing the download (the LCD displays '**Completed**'), leave the SP mode.

**NOTE:** It takes approximately 2.5 minutes to complete.

8. Turn off the main switch, and then remove the flash memory card.
9. Turn on the main switch, then enter the SP mode again and check the updated ROM version with SP1-19-5.



## 5. PREVENTIVE MAINTENANCE

### 5.1 MAINTENANCE TABLE

The following items should be maintained periodically. There are two sets of intervals - one based on time and the other based on print count. For maintenance items with entries in both of them, use whichever comes first.

C: Clean, R: Replace, L: Lubricate, A: Adjust

Item	Interval	Time				Print Counter					EM	NOTE
		6M	1Y	2Y	3Y	300K	600K	1M	1.2M	2M		
<b>Scanner/Optics</b>												
Exposure Lamp		C	C	C	C							Dry Cloth
Mirror/Reflector		C	C	C	C							Soft Cloth
Scanner Guide Rail		C	C	C	C							Dry Cloth
Platen Cover / White Plate		C	C	C	C							Damp Cloth
Exposure Glass		C	C	C	C							Dry Cloth
<b>Master Feed</b>												
Thermal Head											C	Alcohol
Platen Roller		C	C	C	R							Expected life is 6K masters.
Master Eject Rollers		C	C	C	C							Alcohol
Master Eject Box		C	C	C	C							Alcohol
1st and 2nd Drum Master Sensors											C	Dry Cloth
<b>Paper Feed</b>												
Paper Pick-up Roller		C	C	R	C				R			Damp Cloth
Paper Feed Roller		C	C	R	C				R			Damp Cloth
Paper Feed and Pick-up Roller One-way Clutches				R					R			
Friction Pads		C	C	R	C				R			Damp Cloth
Feed Roller and Transport Belt Roller Bushings			L	L	L							Motor Oil (SAE #20)
Feed Drive Gears			L	L	L							Grease (Alvania #2)
Paper Delivery Transport Belts				R					R			
Paper End Sensor		C	C	C	C							Dry Cloth

Preventive Maintenance

Item	Interval	Time				Print Counter					EM	NOTE
		6M	1Y	2Y	3Y	300K	600K	1M	1.2M	2M		
Registration/Feed Timing/Exit Sensors	C	C	C	C								Dry Cloth
Registration Roller	C	C	C	C								Dry Cloth
<b>Drum and Ink Supply</b>												
Cloth Screen			R						R			
Drum Drive Gears and Cam		L	L	L								Grease (Alvania #2)
Drum Flange Bushing		L	L	L								Motor Oil (SAE #20)
In/Outside of Drum	C	C	C	C								Alcohol
Ink Nozzle	C	C	C	C								Alcohol
<b>Others</b>												
Pressure Cylinder	C	C	C	C					C			Damp Cloth
Paper Clamper (on Pressure Cylinder)	C	C	C	C					C			Dry Cloth
Timing Belt Tension			A									
<b>ADF (Option)</b>												
DF Feed Rollers	C	C	C	C								Dry Cloth

## 6. REPLACEMENT AND ADJUSTMENT

### 6.1 EXTERIOR

#### 6.1.1 EXPOSURE GLASS, OPERATION PANEL, AND UPPER COVERS

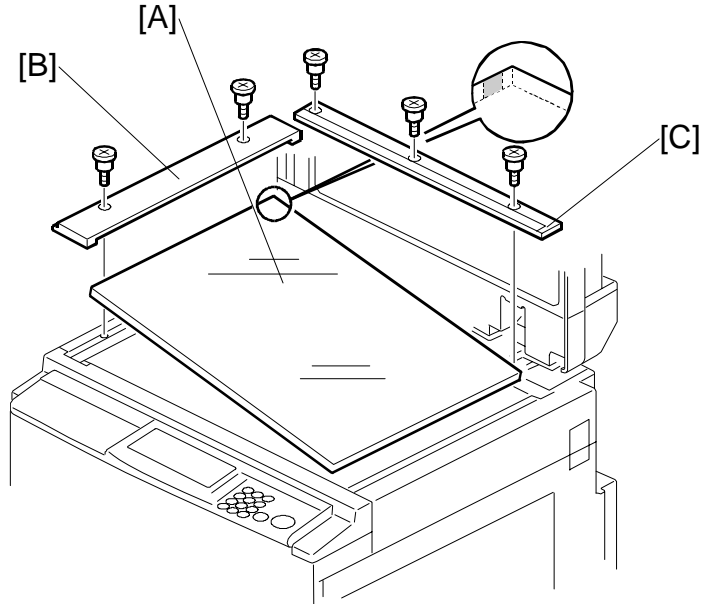

C235D015.WMF

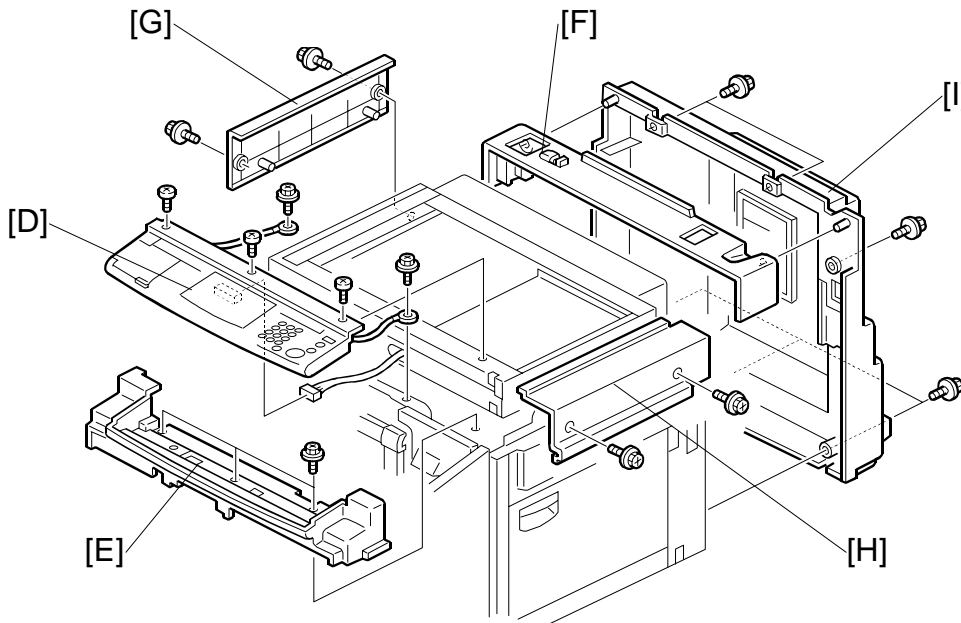

C235R002.WMF

Replacement  
Adjustment

A: Exposure glass (First, remove the left scale [B] and upper scale [C].)

EXTERIOR

1 February, 2001

D: Operation panel

E: Lower operation panel cover

F: Rear upper cover

G: Left scanner cover

H. Right scanner cover

I. Rear cover

## 6.1.2 FRONT DOOR, AND RIGHT FRONT AND RIGHT REAR COVERS

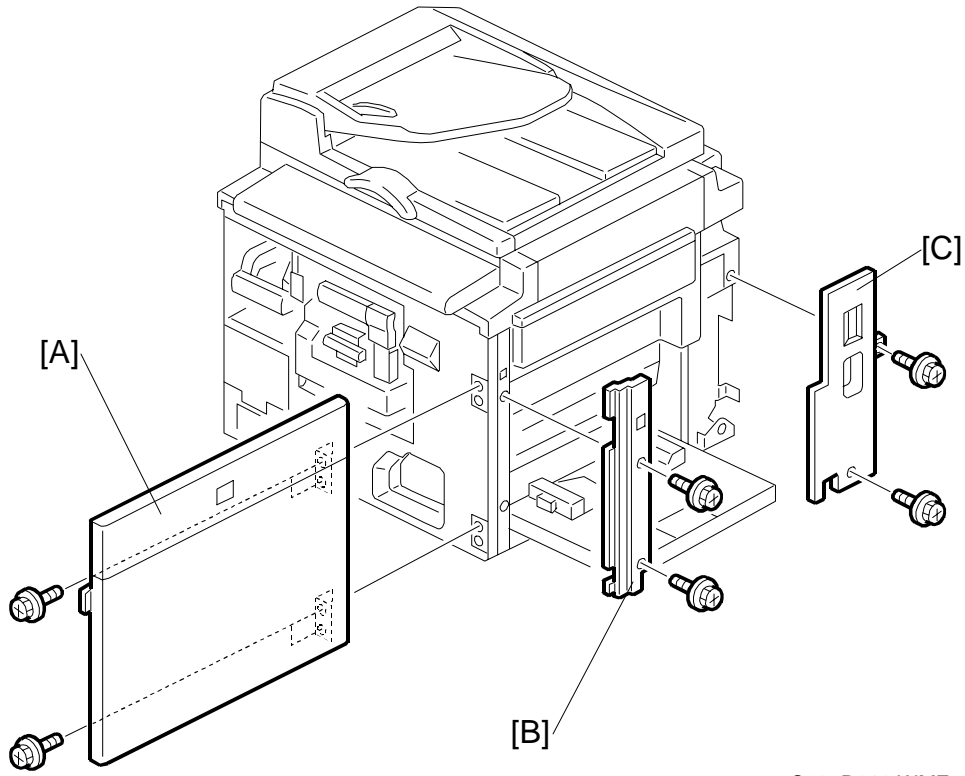

C235R610.WMF

- A: Front door
- B: Right front cover
- C: Right rear cover

Replacement  
Adjustment

### 6.1.3 INNER COVER AND KNOB COVER

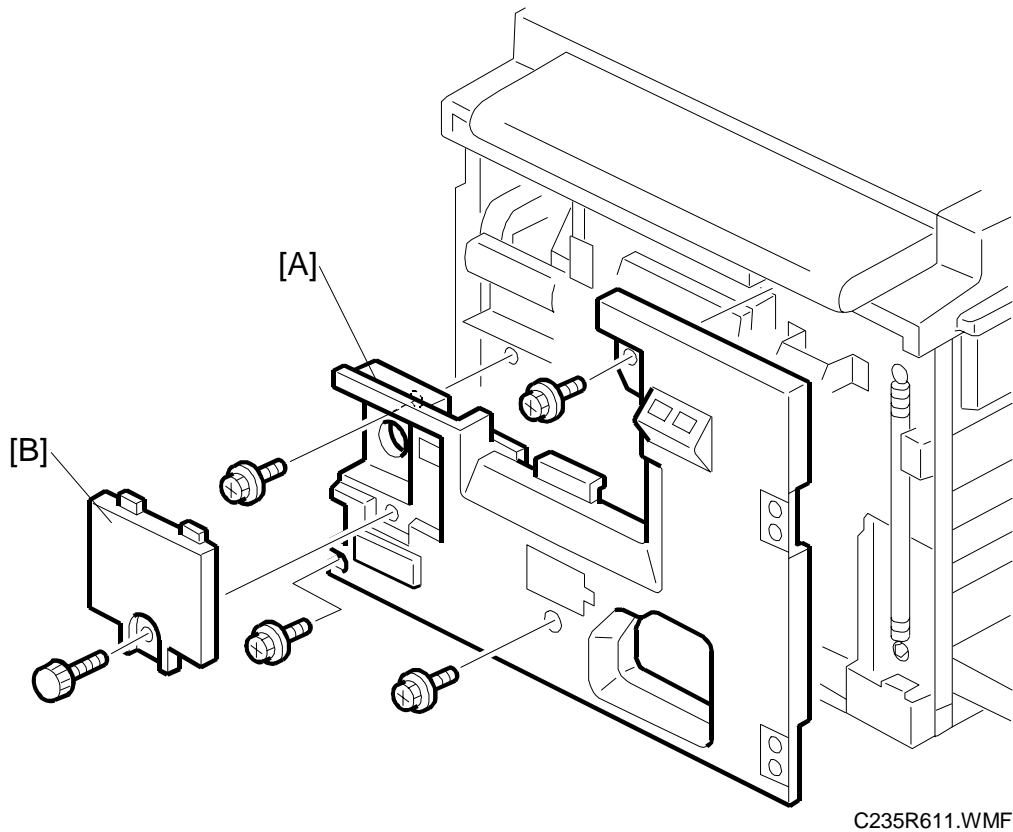

- A: Inner cover
- B: Knob cover

## 6.2 COPY IMAGE ADJUSTMENT

### 6.2.1 LEADING EDGE REGISTRATION ADJUSTMENT

**PURPOSE:** To adjust the leading edge registration on prints by changing the image scanning start positions in platen and ADF modes.

**ADJUSTMENT STANDARD:**

Within -2.0 to 5.0 mm (in platen mode)

Within  $0 \pm 5.0$  mm (in ADF mode)

**CAUTION:** This adjustment is required every time the MPU has been replaced.

1. Turn on the main switch, and make a copy in platen mode.

**NOTE:** The image position on the trial print that is automatically made after making a master tends to be inconstant. Do not use the trial print to check the copy image.

2. Measure the difference between the leading edge registration of the original and the print. If the registration does not meet specifications, go to the next step.
3. Access SP6-001-3 (Scan Start Position Adjustment - Platen Mode).
4. Adjust the gap.
5. Exit the SP mode and make a copy.
6. Re-measure the leading edge registration to ensure it is within specifications. If the registration meets specifications, go to the next step.
7. Make a copy in ADF mode and repeat the same steps using SP6-001-4 (Scan Start Position - DF Mode). The specification in ADF mode is  $0 \pm 5.0$  mm.

**NOTE:** The master clamping position is adjustable using SP6-003-1 (Drum Master Clamp Registration). Changing the clamping position with this SP also adjusts the leading edge registration. Normally, do not use this SP mode for adjusting the leading edge registration.

## 6.2.2 SIDE-TO-SIDE REGISTRATION ADJUSTMENT

**PURPOSE:** To adjust the side-to-side image position on prints by changing the main-scan positions in platen and ADF modes.

**ADJUSTMENT STANDARD:**

Within -5.0 to 2.0 mm (in platen mode)

Within  $0 \pm 5.0$  mm (in ADF mode)

**CAUTION:** This adjustment is required every time the MPU has been replaced.

1. Turn on the main switch, and make a copy in platen mode.

**NOTE:** The image position on the trial print that is automatically made after making a master tends to be inconstant. Do not use the trial print to check the copy image.

2. Measure the difference between the side-to-side edge registration of the original and the print. If the registration does not meet specifications, go to the next step.
3. Access SP6-001-1 (Main-scan Position - Platen Mode).
4. Adjust the gap.
5. Exit the SP mode and make a copy.
6. Re-measure the side-to-side registration to ensure it is within specifications. If the registration meets specifications, go to the next step.
7. Make a copy in ADF mode and repeat the same steps using SP6-001-2 (Main-scan Position - DF Mode). The specification in ADF mode is  $0 \pm 5.0$  mm.



### 6.2.3 VERTICAL MAGNIFICATION ADJUSTMENT

**PURPOSE:** To adjust the vertical magnification to within the adjustment standard by changing the scanning speeds in platen and ADF modes.

**ADJUSTMENT STANDARD:**

Within  $100 \pm 1.0\%$

**CAUTION:** This adjustment is required every time the MPU has been replaced.

1. Turn on the main switch, and make a copy in platen mode.

**NOTE:** The image position on the trial print that is automatically made after making a master tends to be inconstant. Do not use the trial print to check the copy image.

2. Measure the difference between the magnification of the original and the print. If the vertical magnification does not meet specifications, go to the next step.
3. Access SP6-001-5 (Scanning Speed - Platen Mode).
4. Adjust the value.
5. Exit the SP mode and make a copy.
6. Check the vertical magnification again to ensure it is within specifications. If the vertical magnification meets specifications, go to the next step.
7. Make a copy in ADF mode and repeat the same steps using SP6-001-6 (Scanning Speed - DF Mode).

**NOTE:** The master feed speed during image writing can be adjusted with SP6-001-7 (Master Writing Speed). Changing the speed with this SP also adjusts the vertical magnification. Normally, do not use this SP mode for adjusting the vertical magnification.

## 6.3 MPU AND I/O BOARD REPLACEMENT

SP mode data and other adjustment data are stored in the backup RAM on the MPU. There are adjustable potentiometers on the I/O board.

Therefore, once the MPU and/or I/O boards are replaced, the following adjustments are needed.

### - When the MPU is replaced -

- The SP mode data returns to the default. Save the data SP mode in order to restore it later. If possible, print out all system parameter lists using from SP8-001-1 to SP8-001-14. (The optional memory board is required to use the data printout function.)
- Carry out all copy image adjustments. (See "6.2 Copy Image Adjustment".)
- Sensor board unit calibration. (See "6.5.8 Sensor Board Unit Calibration".)
- Master end sensor adjustment. (See "6.7.7 Master End Sensor Adjustment".)

**NOTE:** If you use the backup RAM [A] (IC117) from the old MPU on the new one, all data, including data in the SP modes, will be restored. You do not have to do the above procedures. (The battery inside the RAM preserves the data even if the RAM is removed from the MPU.)

### - When the I/O board is replaced -

- Carry out the adjustments for the 1st drum master, 2nd drum master, master eject, and master edge sensors. (When both MPU and I/O board are replaced, carry out the master end sensor adjustment, also.)

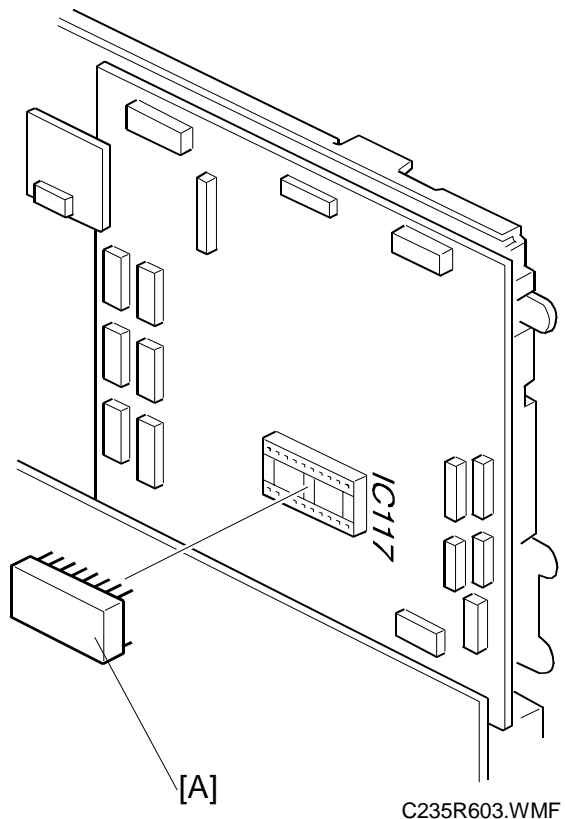

C235R603.WMF

## 6.4 MPU AND PSU OPENING PROCEDURES

### *Opening the MPU*

First, remove the rear exterior cover.

A: Memory board

B: SBU cable

Then, remove 7 screws securing the MPU bracket to flip over the MPU.

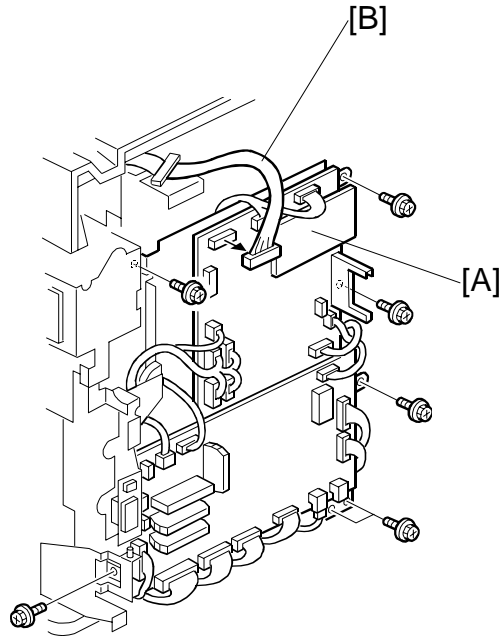

C235R020.WMF

### *Opening the PSU*

First, remove the rear exterior cover.

Then, remove 6 screws to flip over the PSU [C].

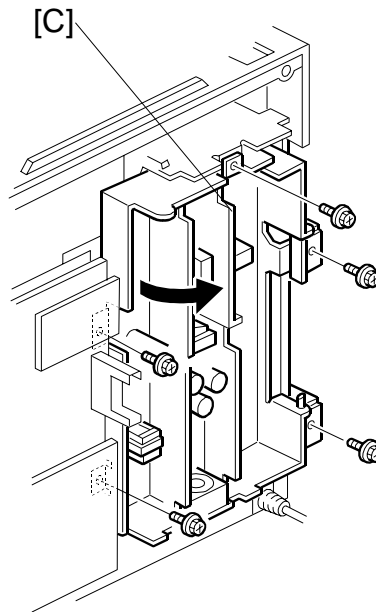

C235R021.WMF

Replacement  
Adjustment

## 6.5 SCANNER UNIT

### 6.5.1 LENS COVER

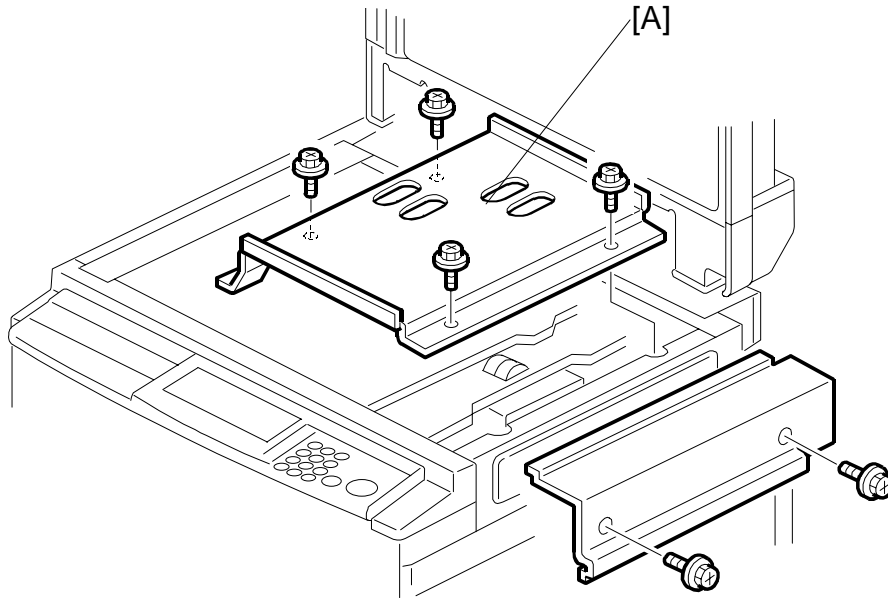

C235R516.WMF

1. Remove the scales, exposure glass and right scanner cover. (See 6.1.1 Exposure Glass, Operation Panel, and Upper Covers.)
2. Remove the lens cover [A] (4 screws).

## 6.5.2 SCANNER FRAME

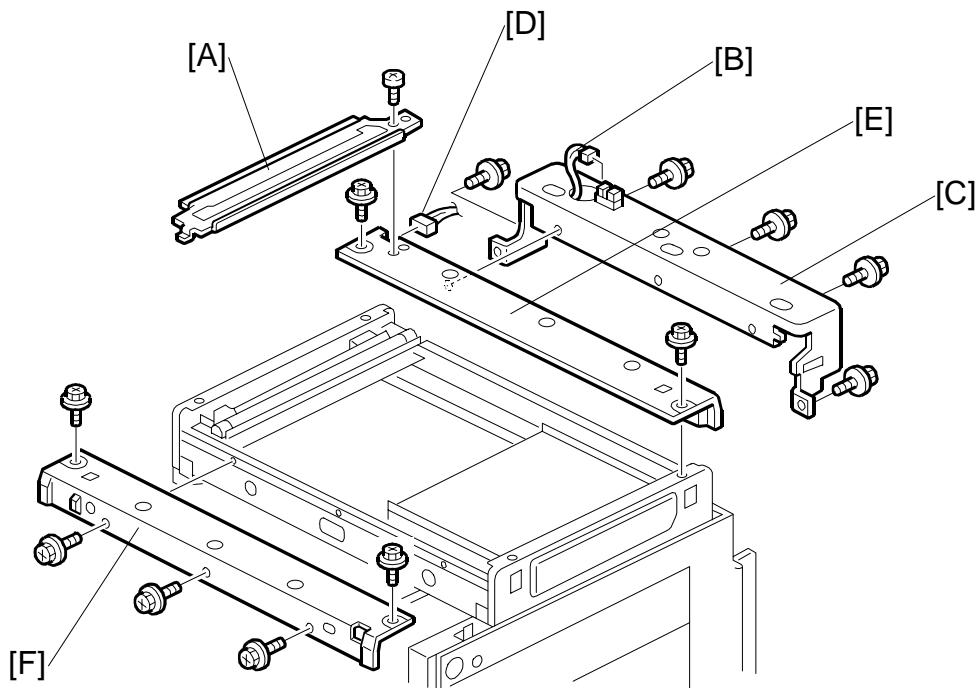

C235D019.WMF

1. Remove the platen cover (ADF).
2. Remove all parts indicated in 6.1.1 Exposure Glass, Operation Panel, and Upper Covers section.
3. Remove the exposure glass bracket [A] (1 screw).
4. Disconnect the platen cover sensor [B] and remove the lower rear scanner frame [C] (5 screws).
5. Disconnect the scanner H.P. sensor [D] and remove the upper rear scanner frame [E] (2 screws).
6. Remove the front scanner frame [F] (5 screws).

Replacement  
Adjustment

### 6.5.3 ORIGINAL SIZE SENSOR, LENS BLOCK/SBU ASSEMBLY AND LAMP STABILIZER

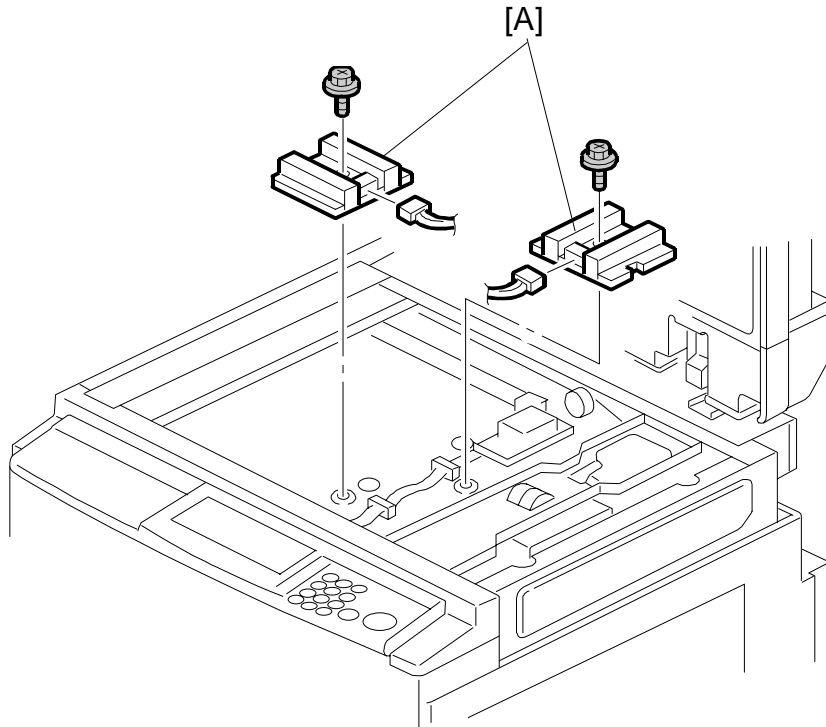

C235D016.WMF

#### ***Original Size Sensors***

1. Remove the exposure glass. (See 6.1.1 Exposure Glass, Operation Panel, and Upper Covers.)
2. Remove the lens covers. (See 6.5.1 Lens Cover.)
3. Change the original size sensors [A]: two for 110/120 V machines and three for 220/240 V machines (2 screws each).

### ***Lens Block/SBU Assembly***

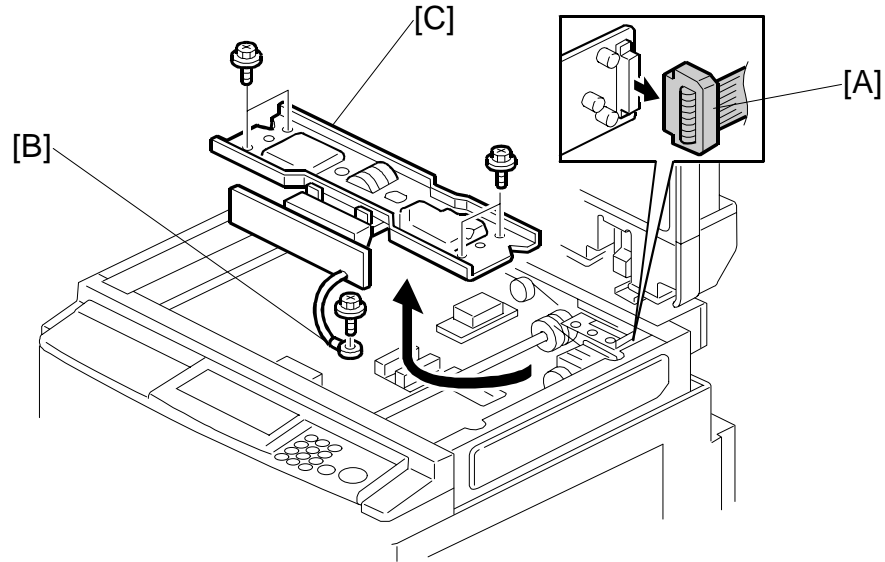

C235R418.WMF

1. Remove the exposure glass and operation panel. (See 6.1.1 Exposure Glass, Operation Panel, and Upper Covers.)
2. Remove the lens covers. (See 6.5.1 Lens Cover.)
3. Disconnect the SBU cable [A].
4. Remove the grounding wire [B] (1 screw).
5. Remove the lens block [C] (4 screws).

Replacement  
Adjustment

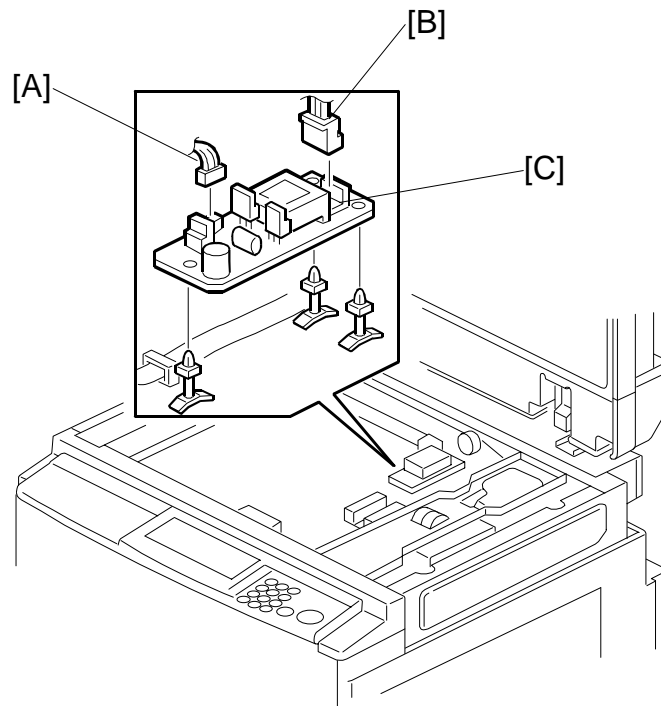
**Lamp Stabilizer**

C235D017.WMF

1. Remove the exposure glass and operation panel. (See 6.1.1 Exposure Glass, Operation Panel, and Upper Covers.)
2. Remove the lens covers. (See 6.5.1 Lens Cover.)
3. Disconnect the cables [A] [B].
4. Remove the lamp stabilizer [C].



### 6.5.4 XENON LAMP

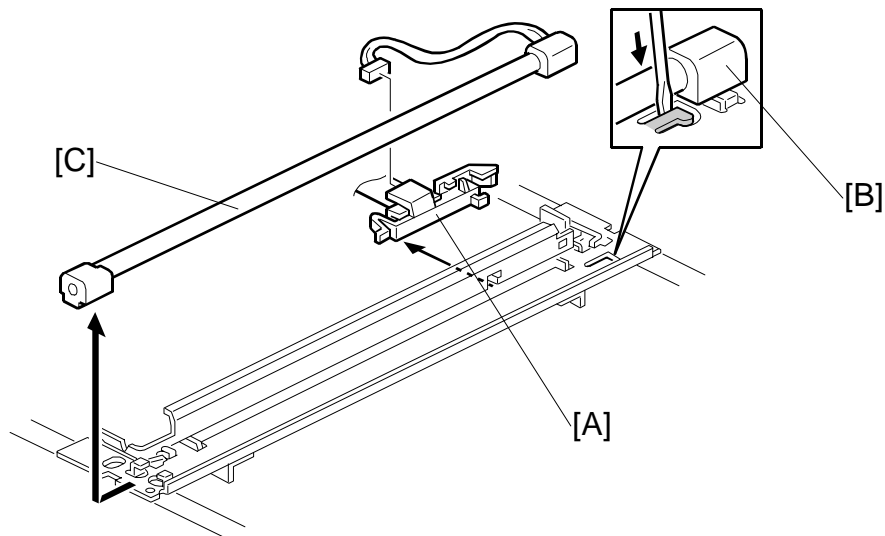

C235R420.WMF

1. Remove the exposure glass and operation panel. (See 6.1.1 Exposure Glass, Operation Panel, and Upper Covers.)
2. Remove the scanner frames. (See 6.5.2 Scanner Frame.)
3. Remove the connector cover [A].
4. Press the lamp holder [B] down with a screwdriver, as shown.
5. Slide the xenon lamp [C] forward and remove it (1 connector).  
**NOTE:** Do not touch the glass surface of the xenon lamp with your fingers.
6. After installing the new lamp, press the lamp holder up to the original position so that it can hold the lamp properly.

Replacement  
Adjustment

### 6.5.5 SCANNER H. P. SENSOR/PLATEN COVER SENSOR

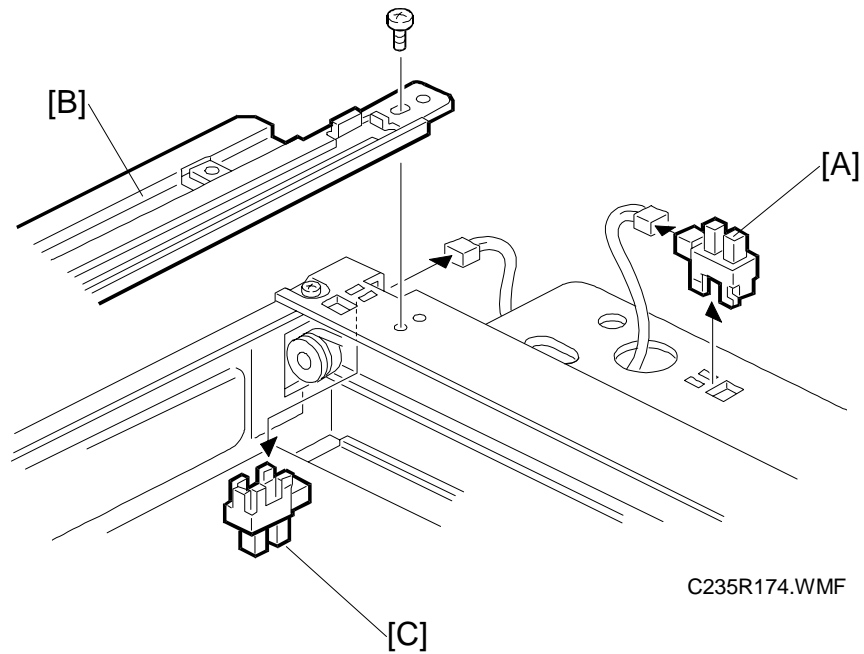

1. Remove the exposure glass and upper rear cover. (See 6.1.1 Exposure Glass, Operation Panel, and Upper Covers.)
2. Replace the platen cover sensor [A] (1 connector).
3. Remove the scale bracket [B] (1 screw) and replace the scanner H.P. sensor [C].

## 6.5.6 SCANNER MOTOR

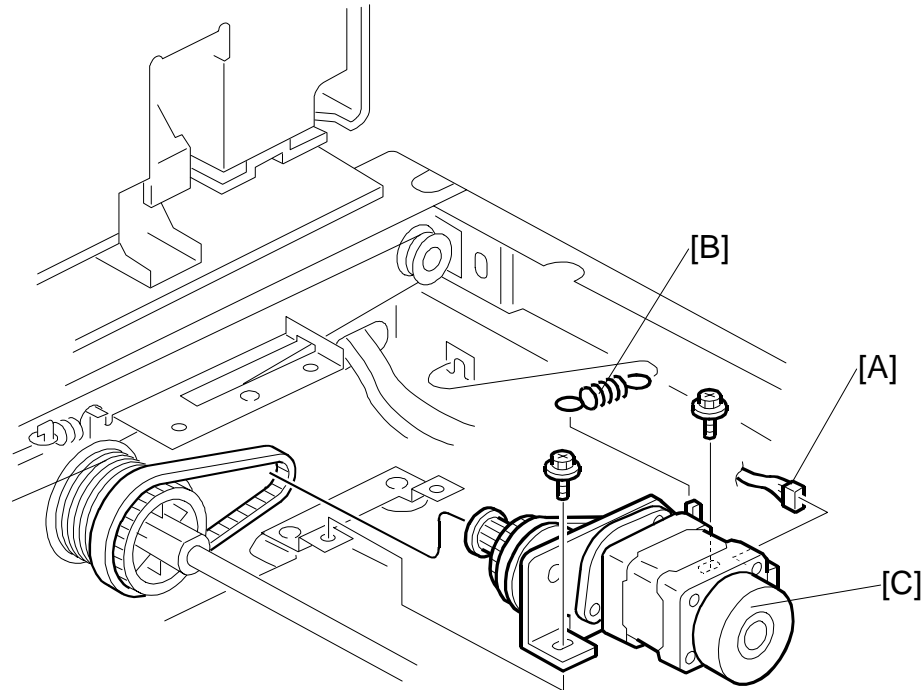

C235R003.WMF

1. Remove the exposure glass and operation panel. (See 6.1.1 Exposure Glass, Operation Panel, and Upper Covers.)
2. Remove the lens covers. (See Lens Cover.)
3. Remove the scanner frames. (See Scanner Frame.)
4. Disconnect the cable [A].
5. Remove the tension spring [B].
6. Remove the motor and bracket [C] (2 screws).
7. Secure the new motor with the tension spring.

Replacement  
Adjustment

### 6.5.7 SCANNER WIRE

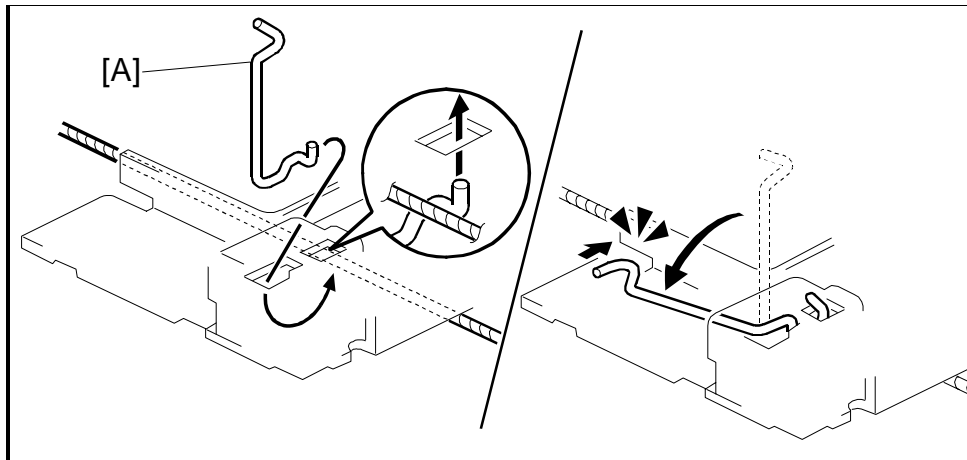

C235D023.WMF

1. Remove the exposure glass, operation panel, and all scanner exterior covers. (See exposure glass, operation panel, and upper covers.)
2. Remove the lens covers. (See 6.5.1 Lens Cover.)
3. Remove the scanner frames. (See 6.5.2 Scanner Frame.)
4. Remove the front and rear scanner wire pins [A]. Then, remove the 1st scanner.

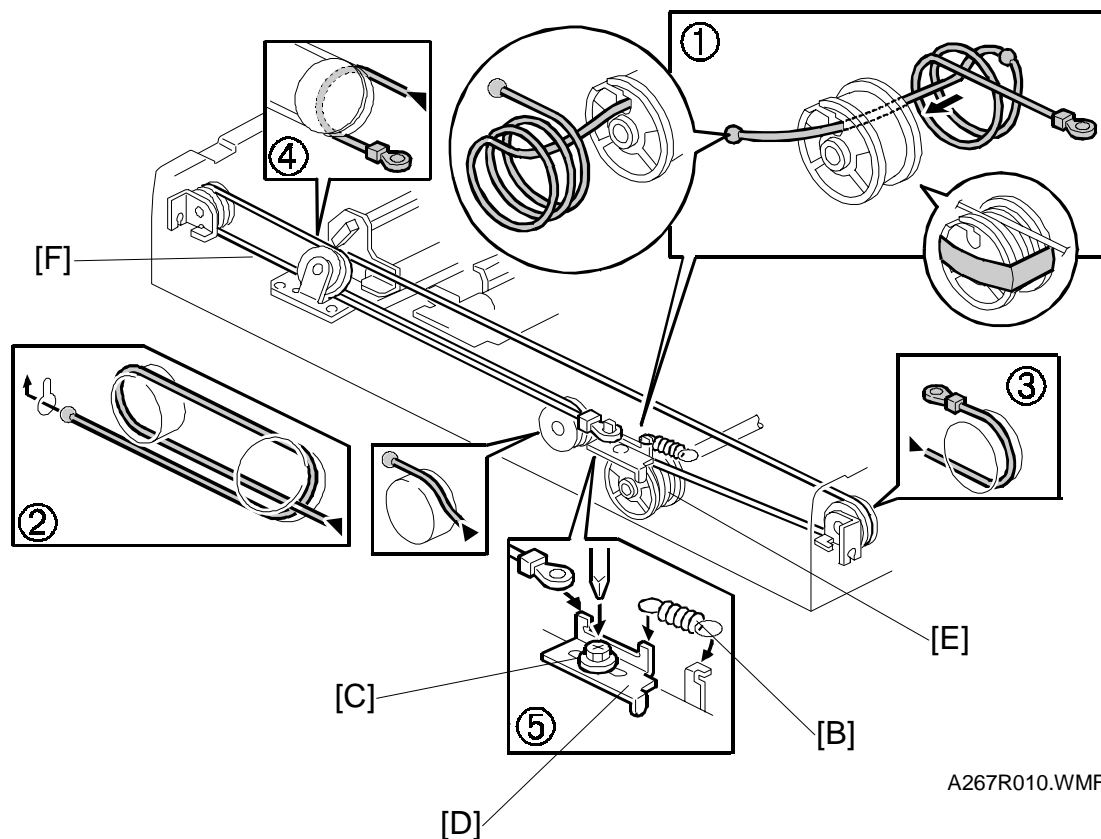

A267R010.WMF

5. Remove the tension spring [B].
6. Loosen the screw [C] securing the wire tension bracket [D].
7. Remove the scanner drive pulley [E] (1 set screw).
8. Remove the scanner wire [F].
9. Wrap the new scanner wire around the pulley as shown ①, then temporarily secure the pulley with tape.
10. Re-install the 1st scanner. Then secure the 1st and 2nd scanner with the scanner positioning pins (P/N A0069104), as shown in the illustration on the next page.
11. Wind the new scanner wire around the scanner drive pulley in the correct way, as shown.
12. Wind the end of the new wire with the ball as shown (②).
13. Wind the end of the new wire with the ring as shown (③,④, and ⑤).
14. Install the tension spring on the wire tension bracket (⑤).
15. Wind the new scanner wire for the other side as well.

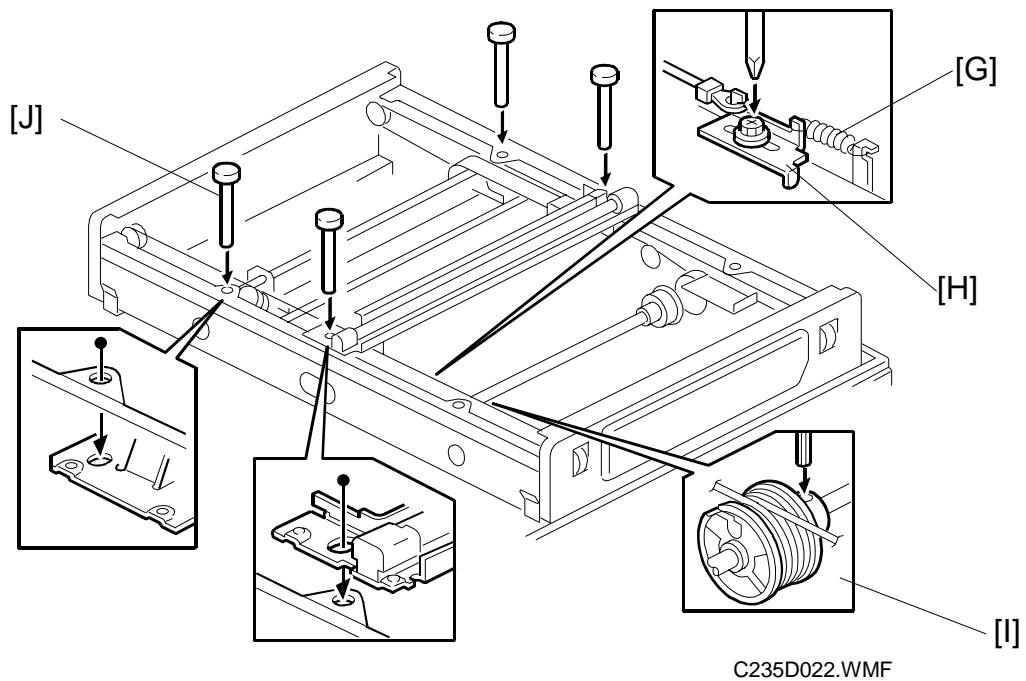

C235D022.WMF

16. Secure the 1st scanner with the scanner wire pins.
17. Install the tension spring [G] to the tension bracket.
18. Tighten the tension bracket [H].
19. Secure the scanner wire pulley [I] (1 Allen screw).
20. Remove the positioning pins [J]
21. Slide the scanner to the left and right several times, then set the scanner positioning pins to check the clamp position and wire tension bracket position again.

## 6.5.8 SENSOR BOARD UNIT CALIBRATION

**PURPOSE:** Perform the SBU auto calibration using the SP mode in the following cases:

- When the MPU is replaced
- When the standard white plate located behind the original scale is replaced.

**PROCEDURE:**

1. Place about 10 sheets of paper on the exposure glass.
2. Turn on the main switch and access the SP mode (Clear Modes  $\Rightarrow$  1  $\Rightarrow$  0  $\Rightarrow$  7  $\Rightarrow$  Clear/Stop).
3. Select SP6-005-1 (SBU Auto Calibration).
4. Press the Enter (#) key to start.

**NOTE:** When the sequence is successful, "Completed" is displayed on the display.

## 6.6 MASTER EJECT SECTION

### 6.6.1 MASTER EJECT ROLLER UNIT

#### *Unit Removal*

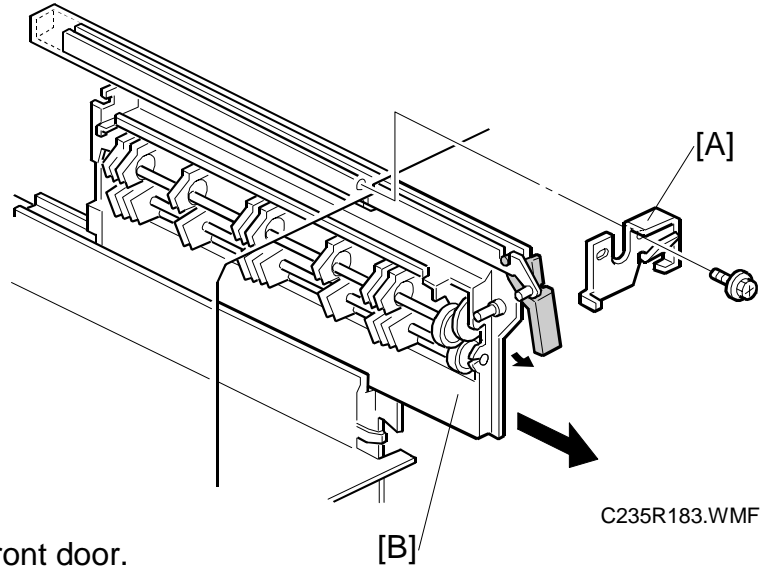

First, open the front door.

A: Supporter

B: Master eject roller unit

#### *Master Eject Sensor*

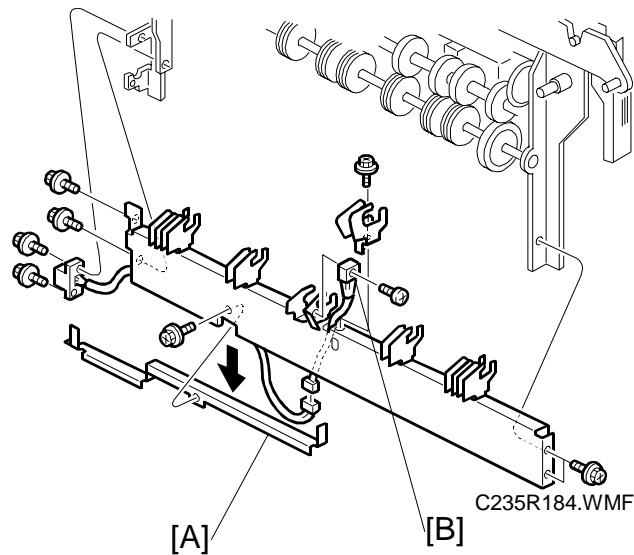

First, remove the master eject roller unit.  
(See the procedure above.)

A: Master eject sensor cover

B: Master eject sensor



## 6.6.2 MASTER EJECT DRIVE UNIT

### *Unit Removal*

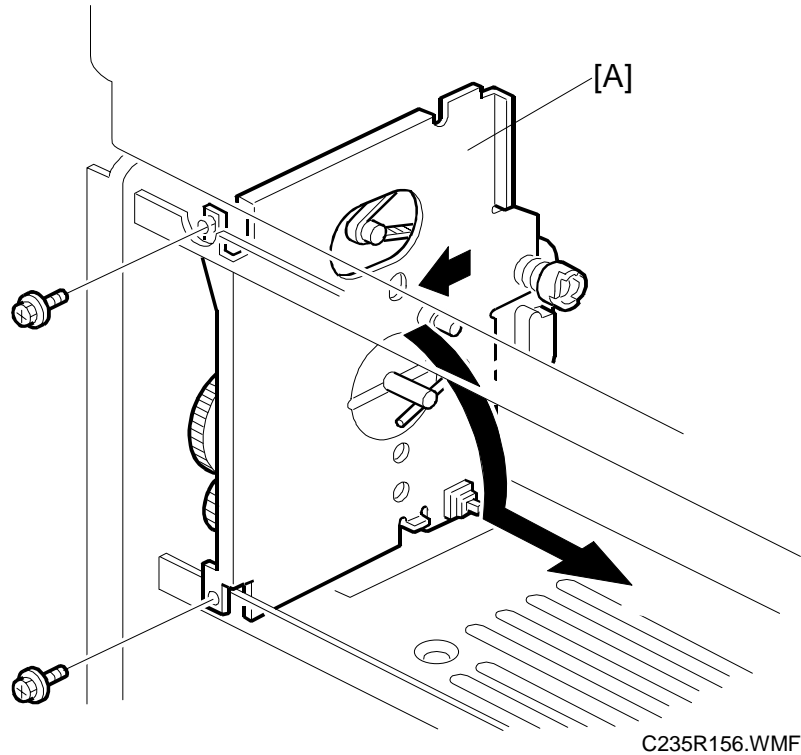

1. Slide out the master eject box and the master eject drive unit.
2. Remove the left exterior cover.
3. To remove the master eject drive unit [A], slide it out in the paper delivery direction, and pull down the top of the unit towards the operation panel. (See the arrows in the illustration.)

**NOTE:** The master eject drive unit is connected to the cables from the sensor and the motor. Remove the master eject unit carefully.

Replacement  
Adjustment

***Sensors and Motors in the Master Eject Drive Unit***

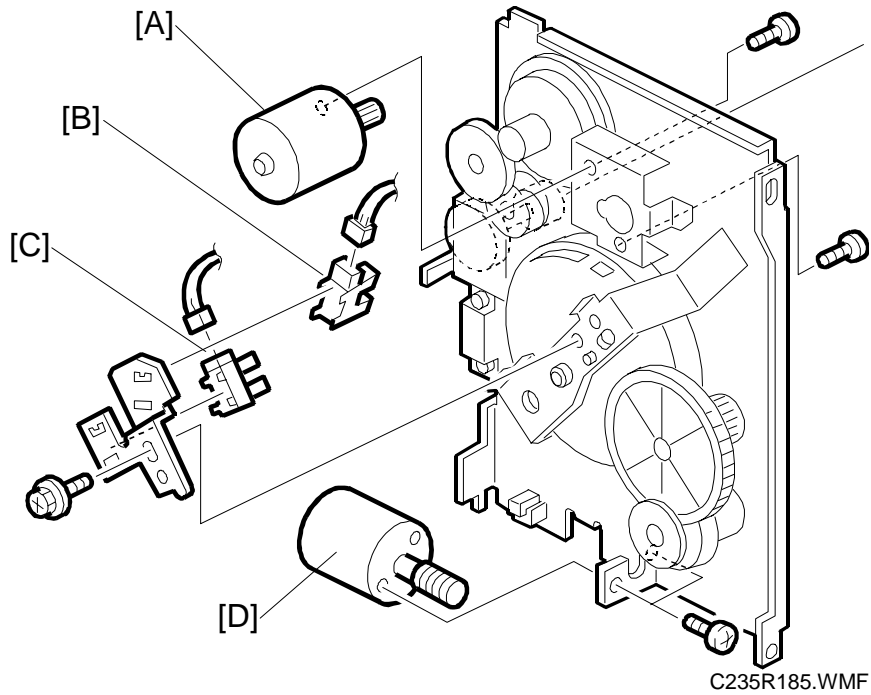

First, remove the master eject drive unit.  
(See the previous procedure.)

- A: Master Eject Motor
- B: Pressure Plate HP Sensor
- C: Pressure Plate Limit Position Sensor
- D: Pressure Plate Motor

### 6.6.3 MASTER EJECT SENSOR ADJUSTMENT

**PURPOSE:** To ensure that the sensor detects the ejected master properly.

- CAUTION:**
- 1) The sensor adjustment is required in the following cases:
    - When the sensor is replaced.
    - When the I/O board is replaced.
  - 2) While adjusting, make sure to attach all exterior covers to avoid external light.
  - 3) Do not turn the VRs excessively. Turn slowly until the LED turns off.
  - 4) If the sensor is dirty, clean or replace it.
  - 5) For how to access SP mode, refer to the Service Program Mode section.

#### PROCEDURE

1. Turn on the main switch, then access SP6-004-1 (Sensor Voltage and Threshold Adjustment for Master Eject Sensor).

**NOTE:** Make sure that the master eject box and drum are installed.

2. Remove the rear cover and access the I/O board. Turn VR303 clockwise until LED302 lights.
3. The sensor input voltage is displayed on the operation panel. Check that it is between 1.0 and 1.5 volts. If it is not, go back to step 2.
4. Leave the SP mode.

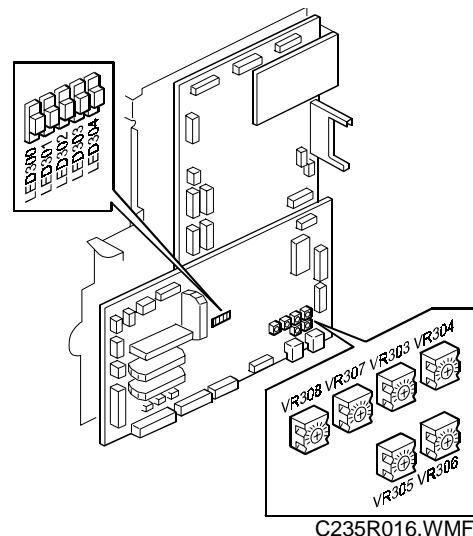

Replacement  
Adjustment

### 6.6.4 REASSEMBLING THE MASTER PICK-UP ROLLER DRIVE GEARS

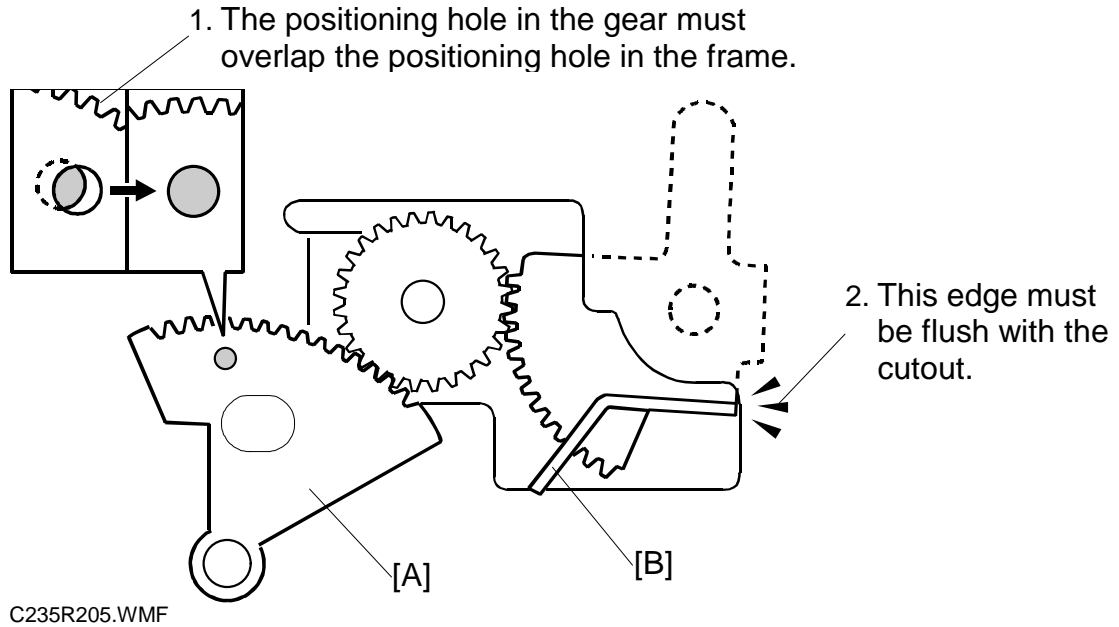

**PURPOSE:** When the master pick-up roller drive sector gear [A] or master eject clamber drive arm [B] have been removed, they must be re-installed in the correct position.

**PROCEDURE:**

1. The master eject clamber drive arm [B] must be flush with the cutout in the frame, as shown.
2. Holding the arm in the above position, install the sector gear [A] so that the small positioning hole in the sector gear exactly overlaps the positioning hole in the frame, as shown.

## 6.7 MASTER FEED SECTION

### 6.7.1 MASTER MAKING UNIT REMOVAL

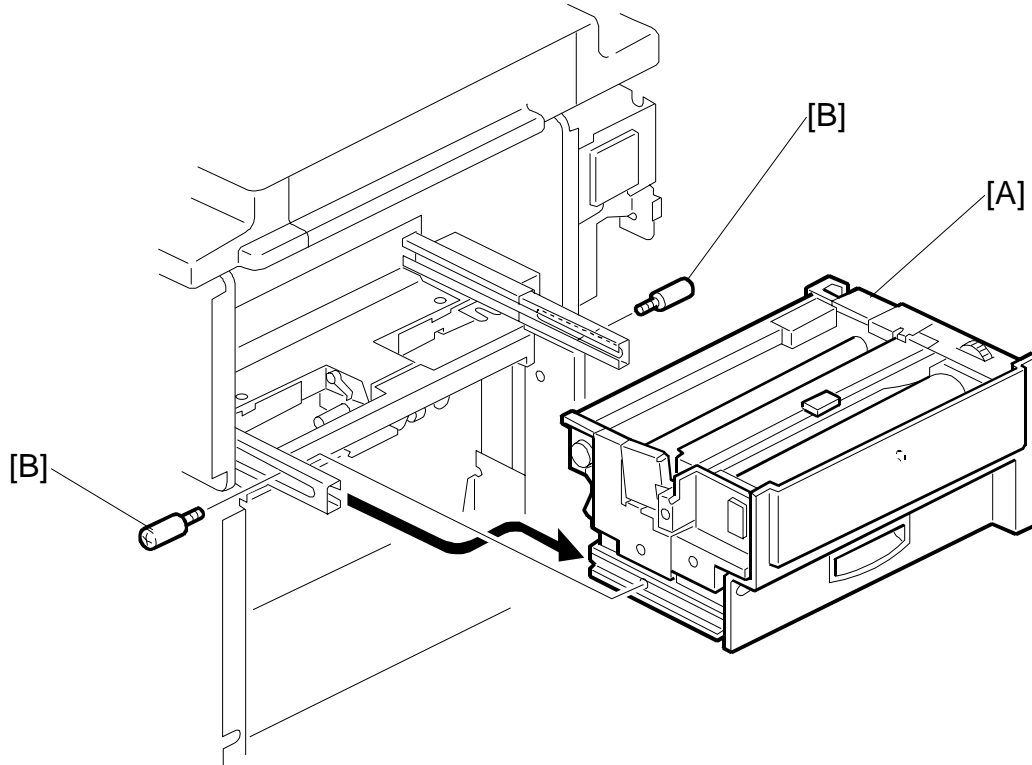

C235R134.WMF

First, slide out the master making unit [A].  
Then, remove it (2 screws [B]).

Replacement  
Adjustment

### 6.7.2 MASTER SET ROLLER AND PLATEN ROLLER

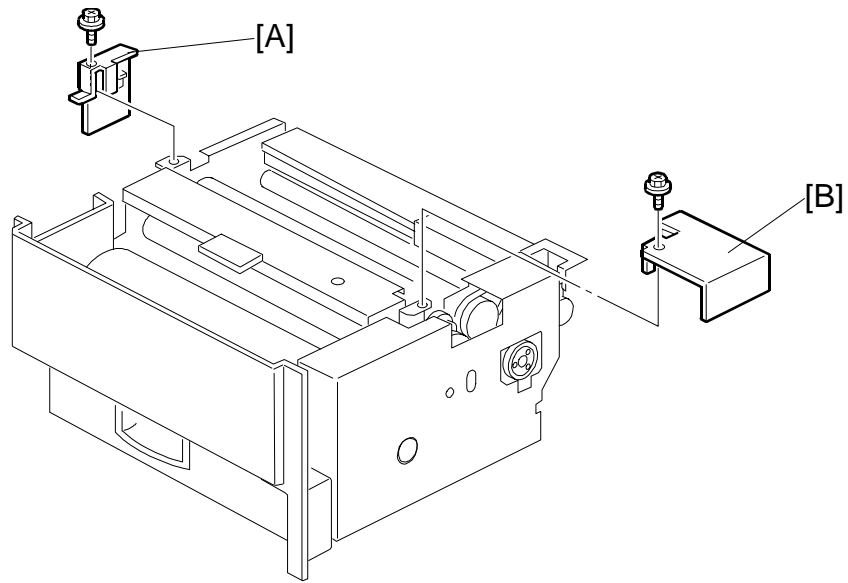

C235R187.WMF

First, remove the master making unit from the machine.

A: Front bracket

B: Rear bracket

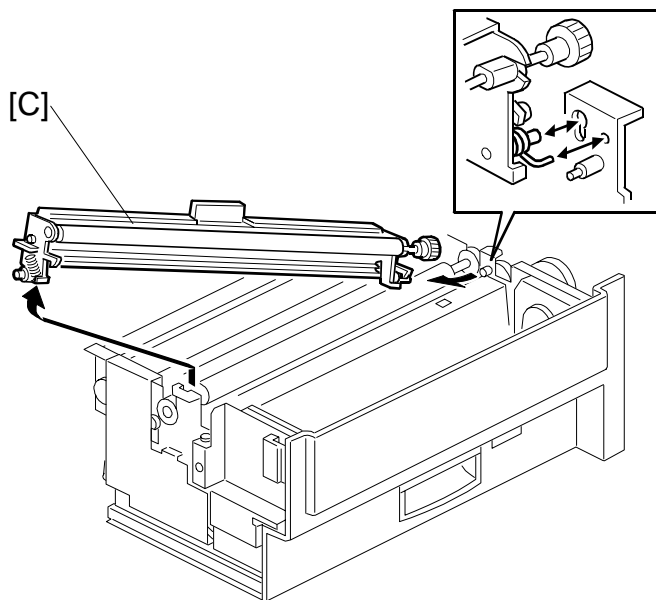

C235R510.WMF

C: Master set roller unit

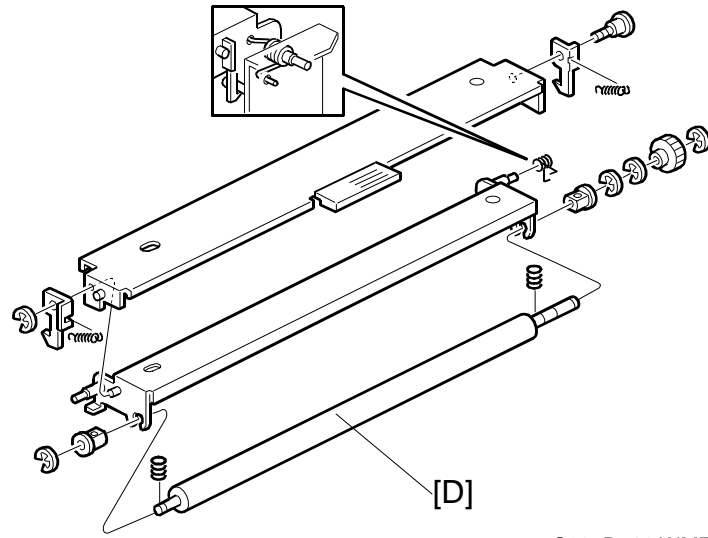

C235R511.WMF

Disassemble the master set roller unit

D: Master set roller

**NOTE:** When re-installing the springs at the non-operation side, refer to the above diagram.

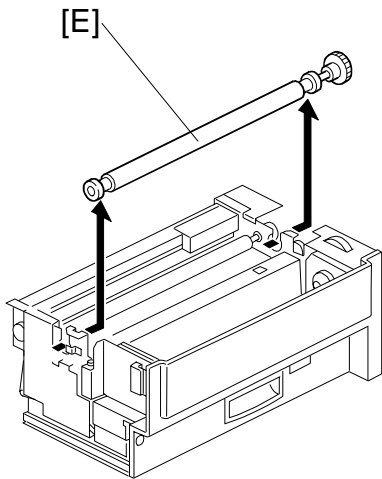

C235R512.WMF

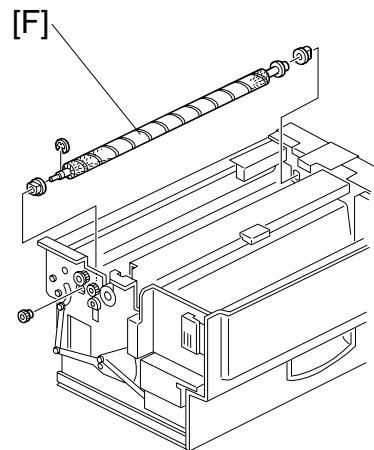

C235R029.WMF

Replacement  
Adjustment

E: Platen roller [E] (slide it towards the operation side)

F: Anti-static roller [F]

**6.7.3 THERMAL HEAD**

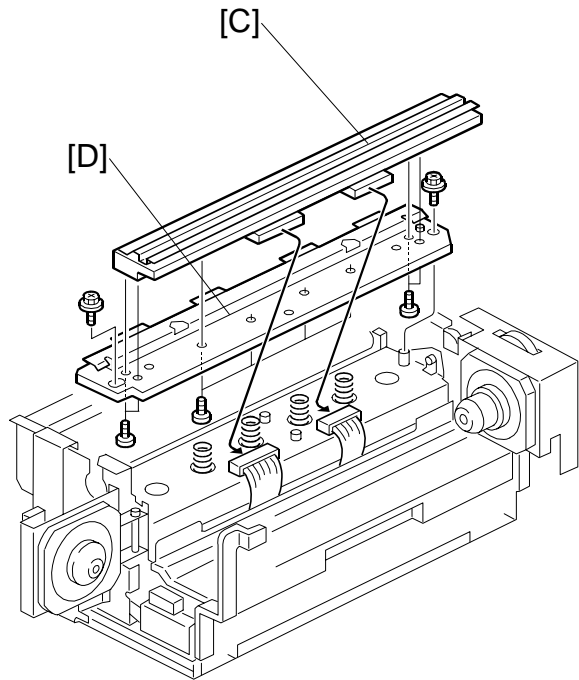
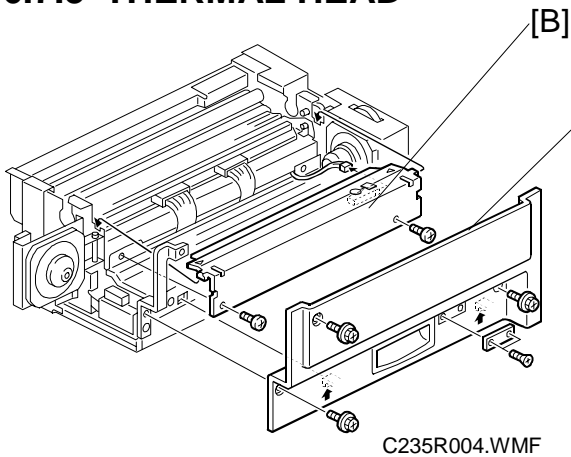

First, remove the platen roller.

A: Master making unit right cover

B: Thermal head cover

C: Thermal head (Disconnect the thermal head connectors)

- CAUTION:**
- 1) After the replacement, adjust the input voltage.
  - 2) There is a small mylar [D] in the base. At reinstallation, make sure that it is in the correct position. (Refer to 6.7.10 Master Feed Mylar Positioning.)
  - 3) Make sure that there is no foreign material on the thermal head surface (especially on the heating elements).  
Don't touch the surface with bare hands. (If you touch it, clean the surface with alcohol.)
  - 4) Similarly, do not touch the surface of the master film with bare hands.
  - 5) Connect and disconnect the connectors carefully.  
Keep them horizontal. Also, make sure that they are reconnected firmly.
  - 6) Don't touch the terminals of the connectors with bare hands.



## 6.7.4 SENSORS, MOTORS, AND CUTTER IN THE MASTER MAKING UNIT

### *Duct Entrance Solenoid*

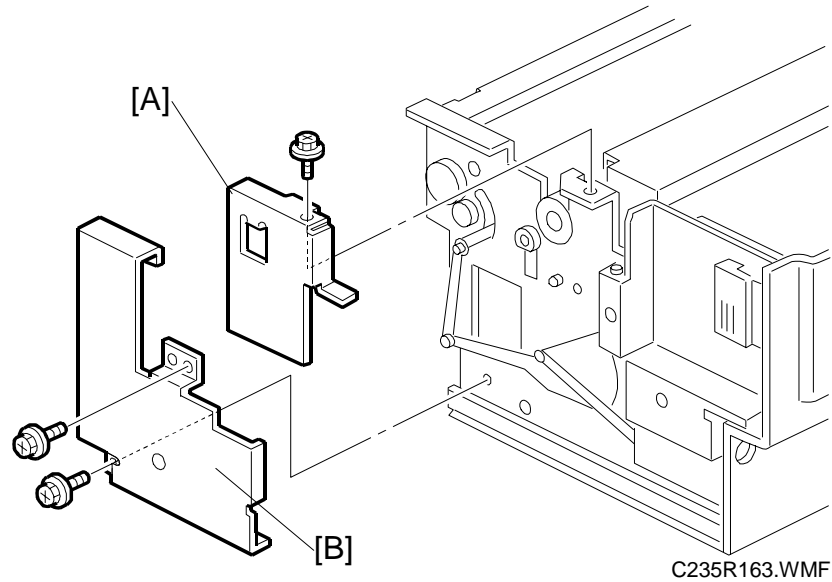

First, remove the master making unit from the machine.

A: Front platen roller bracket

B: Front cover

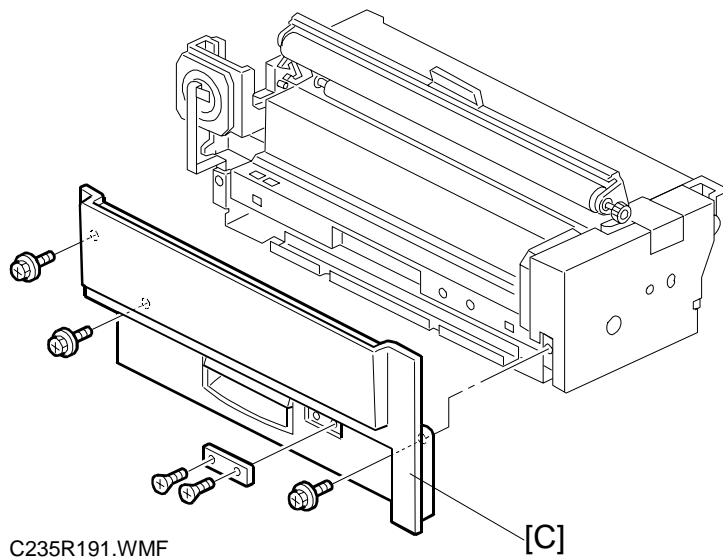

C: Master making unit right cover

Replacement  
Adjustment

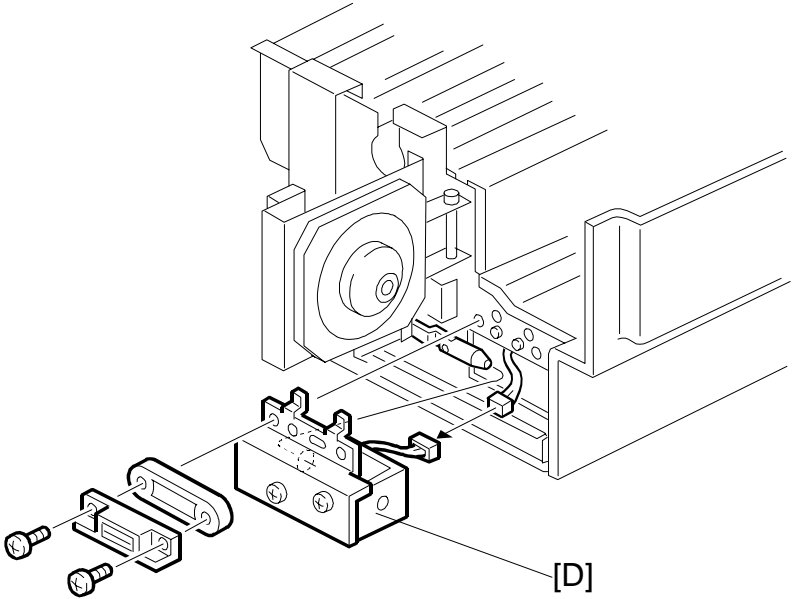

C235R006.WMF

D: Duct entrance solenoid

**Cutter Unit, Platen Release Motor and Sensor, and Master Feed Clutch**

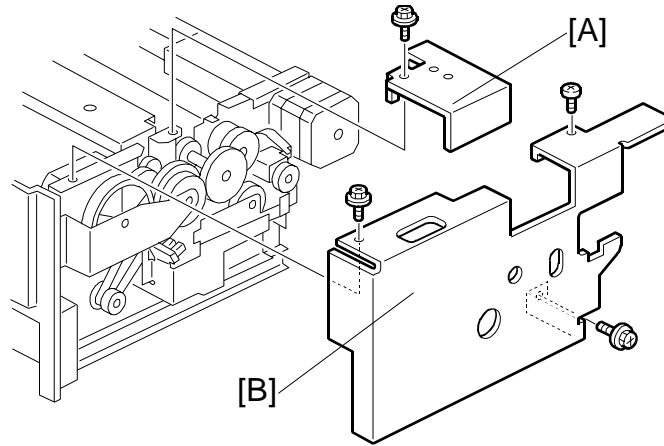

C235R007.WMF

First, remove the master making unit from the machine.

A: Rear platen roller bracket

B: Rear cover

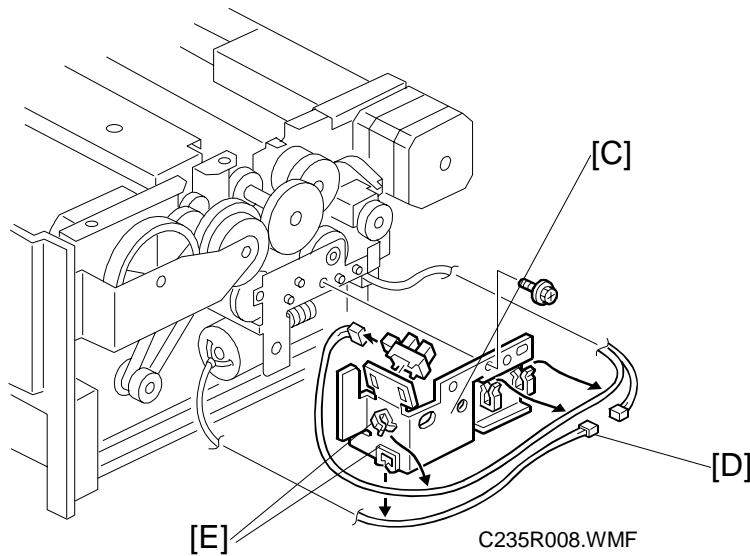

C235R008.WMF

C: Cover bracket

Disconnect the connector [D] between the cutter unit and the cable.

Unhook the wire from the cable clamps [E].

Replacement  
Adjustment

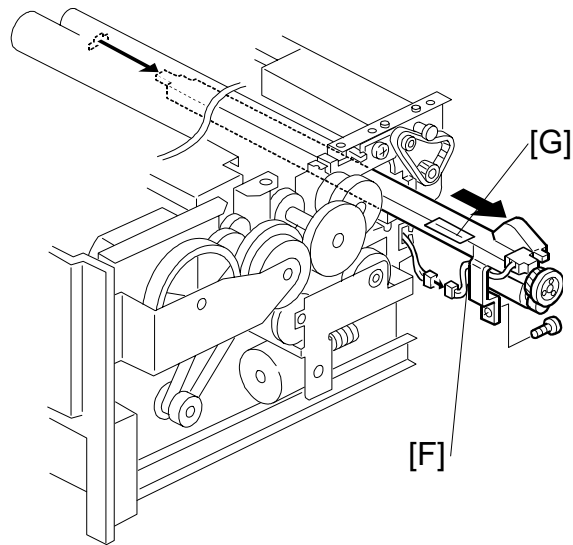

C235R011.WMF

F: Cutter unit

**NOTE:** Make sure that the mylar [G] is in the correct position when reinstalling the cutter unit. There are 6 of these mylars across the length of the cutter unit. (Refer to 6.7.10 Master Feed Mylar Positioning.)

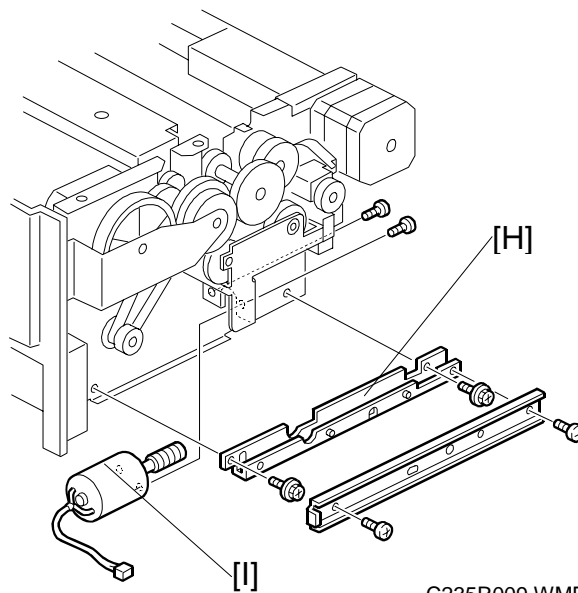

C235R009.WMF

H: Rail

I: Platen release motor

**NOTE:** Make sure that the gear is positioned correctly. Install it in accordance with 6.7.9 Platen Release Cam Adjustment section.

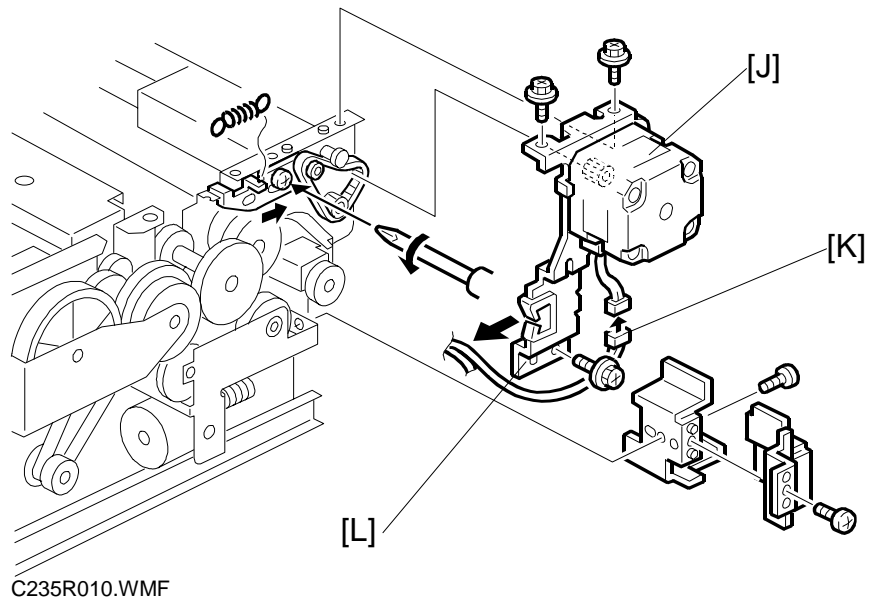

J: Master feed motor

Disconnect the connector [K] between the master feed motor and the cable.

Unhook the wire from the cable clamps [L].

**Master Feed Motor**

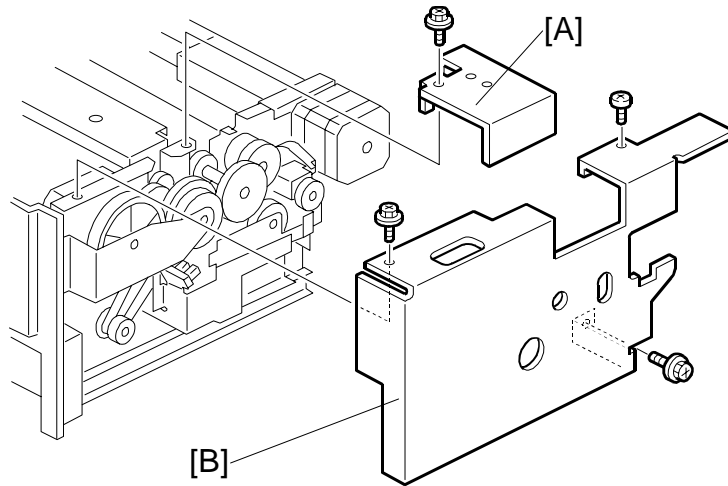

C235R007.WMF

First, remove the master making unit from the machine.

A: Rear platen roller bracket

B: Master making unit rear cover

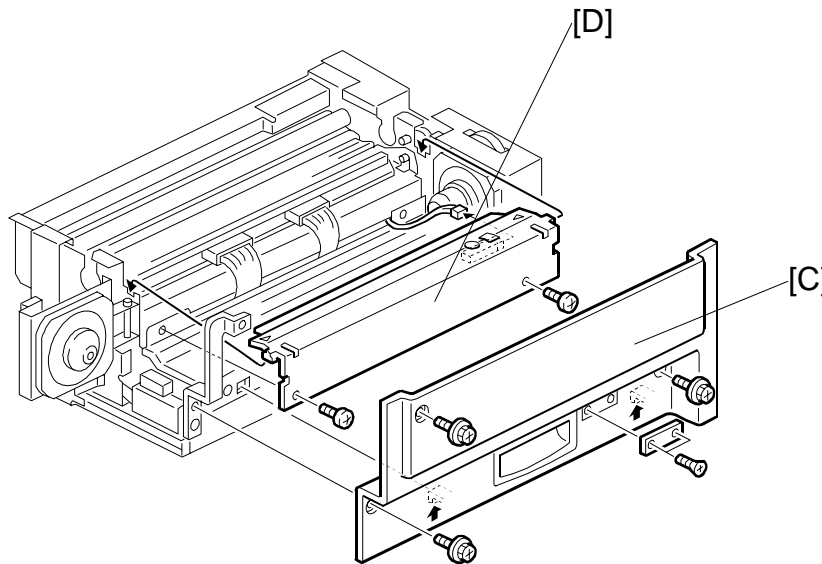

C235R004.WMF

C: Master making unit right cover

D: Thermal head cover

**NOTE:** Take care when removing the thermal head and the stay because these are connected to a cable from a sensor.

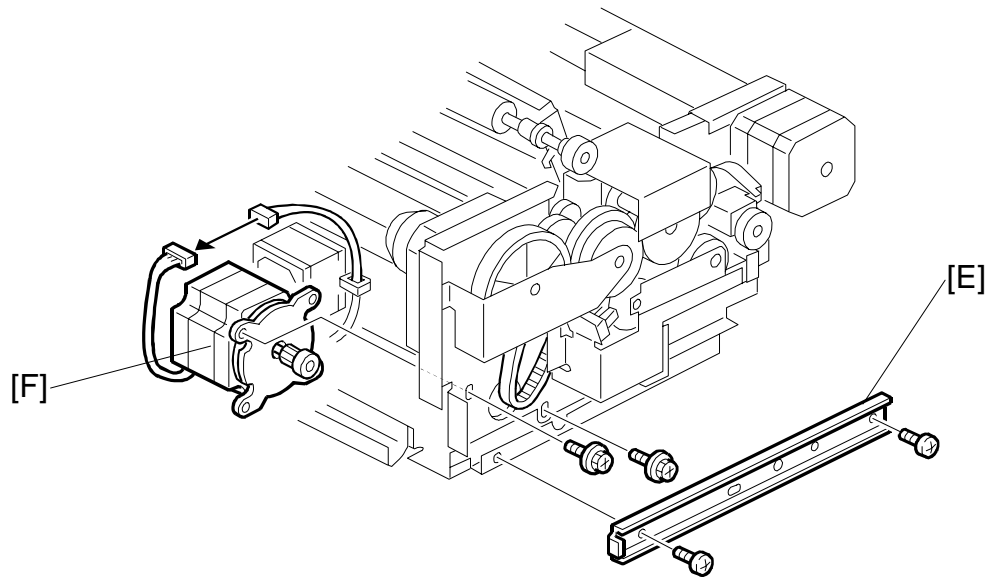

C235R014.WMF

E: Rail

F: Master feed motor

Replacement  
Adjustment

**Master Set Sensor**

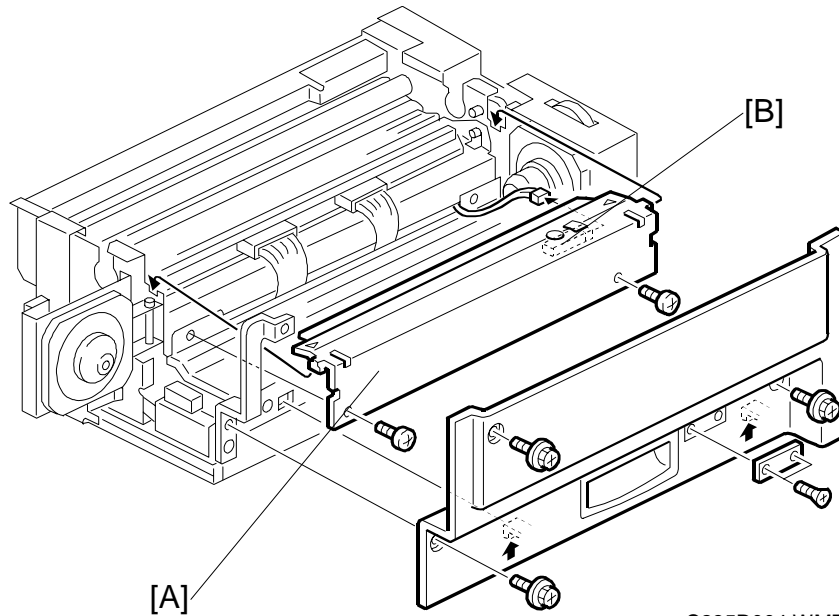

A: Thermal head cover

B: Master set sensor

**NOTE:** Take care when removing the thermal head cover because it is connected to the cable from the sensor.



**Master End Sensor**

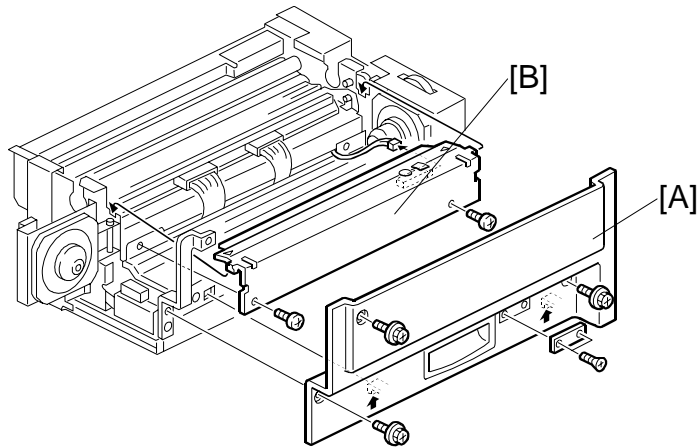

C235R004.WMF

- A: Master making unit right cover
- B: Thermal head cover
- C: Stay (2 screws; not shown in the diagram)

**NOTE:** Be careful when removing the thermal head cover and the stay because these are connected to cables from sensors.

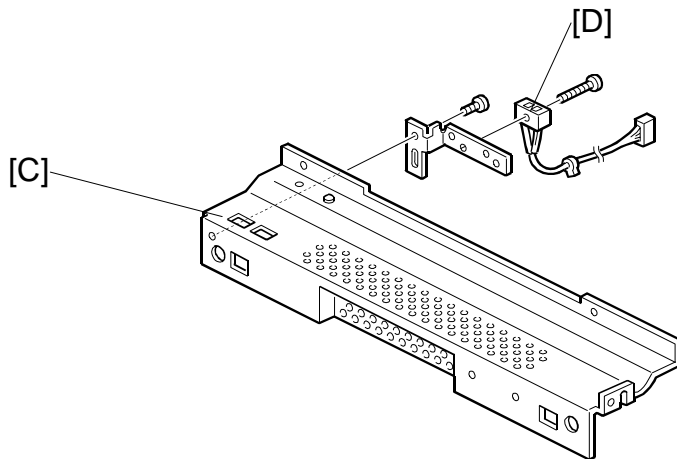

C235R513.WMF

- D: Master end sensor

Replacement  
Adjustment

### 6.7.5 MASTER VACUUM FAN POSITIONING

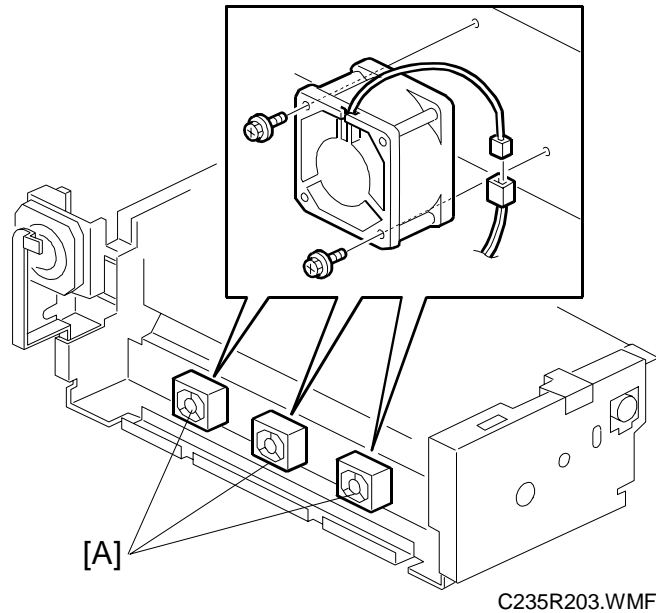

**PURPOSE:** To ensure that the master vacuum fans [A] are installed the correct way around. If they are installed the wrong way around, there will be no suction in the master buffer duct, resulting in master jams.

**PROCEDURE:**

When installing the master vacuum fan [A], position the cable as shown in the diagram.

## 6.7.6 THERMAL HEAD VOLTAGE ADJUSTMENT

**PURPOSE:** To maintain printing quality when making masters and to extend the life time of the thermal head.

### ⚠ CAUTION

- The voltage value affects the durability of the thermal head, and is different for each thermal head. Refer to the exact voltage value that is labeled on each thermal head.
- The adjustment range is between + 0 and – 0.1 volts from the specified value. Never set it out of this range even if there is an image quality problem.

1. Turn off the main switch. Then, remove the rear cover to access the PSU.
2. Check the voltage on the thermal head decal.  
**NOTE:** The value is different for each thermal head.
3. Turn on the main switch and access the SP mode (Clear Modes ⇒ 1 ⇒ 0 ⇒ 7 ⇒ Clear/Stop). Then, select SP 5-010-9 (the thermal head voltage adjustment of the output mode).
4. Press the Start key to apply the voltage to the thermal head. The voltage is continually supplied while the Start key is held down.

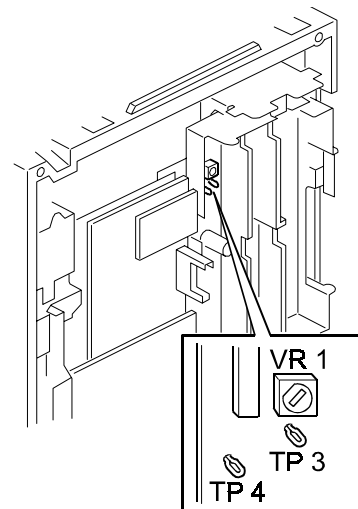

C235R015.WMF

**NOTE:** As another way to apply the voltage, press the  $\#$  key instead of the Start key. However, once the  $\#$  key is pressed, the machine will not stop supplying the voltage until you press the Clear/Stop key or cancel the SP mode. To protect the thermal head, never leave the voltage on for a long time.

5. Measure the voltage between pins TP3 (VHD) and TP4 (GND) on the power supply board. Check that it is between + 0 and – 0.1 volts from the specified value that you read from the decal in step 2.
6. If needed, adjust the voltage by turning VR1 on the power supply board.

**NOTE:** - To increase the voltage: Turn VR1 clockwise  
- To reduce the voltage: Turn VR1 counterclockwise

7. Press the Clear Modes key to leave the SP mode.

### 6.7.7 MASTER END SENSOR ADJUSTMENT

**PURPOSE:** To ensure that the sensor detects the end mark (a solid black area) on the master roll.

**CAUTION:** 1) The sensor adjustment is required in the following cases:  
- When the sensor is replaced.  
- When the MPU is replaced.  
2) If the sensor is dirty, clean or replace it.  
3) For how to access the SP mode, refer to the Service Program Mode section.

**PROCEDURE:**

1. Turn on the main switch, then access SP6-004-4 (Sensor Voltage and Threshold Adjustment for Master End Sensor).
2. The sensor threshold value is displayed on the operation panel. Enter 0.8 (volts) with the number keys.
3. Leave the SP mode.

## 6.7.8 MASTER EDGE SENSOR ADJUSTMENT

**PURPOSE:** To ensure that the sensor detects the master properly.

- CAUTION:**
- 1) The sensor adjustment is required in the following cases:
    - When the sensor is replaced.
    - When the I/O board is replaced.
  - 2) While adjusting, make sure to attach all exterior covers to avoid external light.
  - 3) Do not turn the VRs excessively. Turn slowly until the LED turns off.
  - 4) If the sensor is dirty, clean or replace it.
  - 5) For how to access the SP mode, refer to the Service Program Mode section.

**PROCEDURE:**

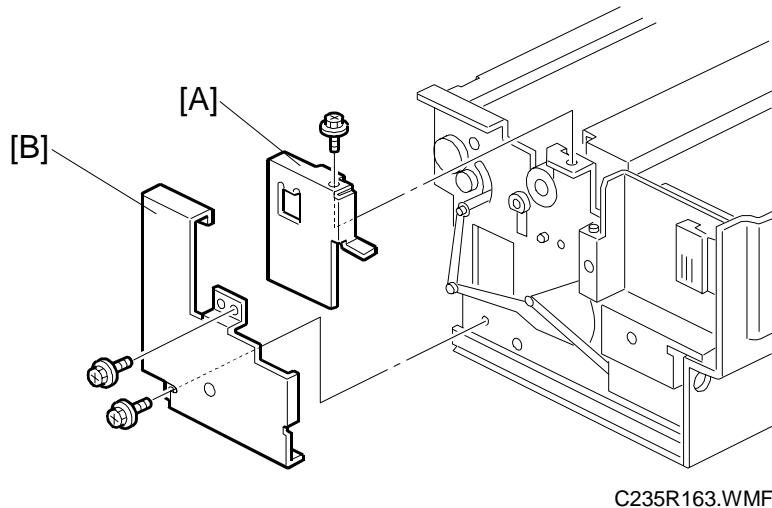

1. Slide out the master making unit.
2. Remove the master roll.  
**NOTE:** The master roll must not be installed for this adjustment.
3. Remove the front platen roller bracket [A] and the front cover [B].

4. Turn on the main switch, then access SP6-004-6 (Sensor Voltage and Threshold Adjustment for Master Edge Sensor).
5. Press the start key. The duct entrance plate closes automatically.
6. Remove the rear cover and access the I/O board. Turn VR307 clockwise until LED301 lights.
7. The sensor input voltage is displayed on the operation panel. Check that it is between 0.85 and 0.95 volts. If it is not, repeat step 7.
8. Leave the SP mode.

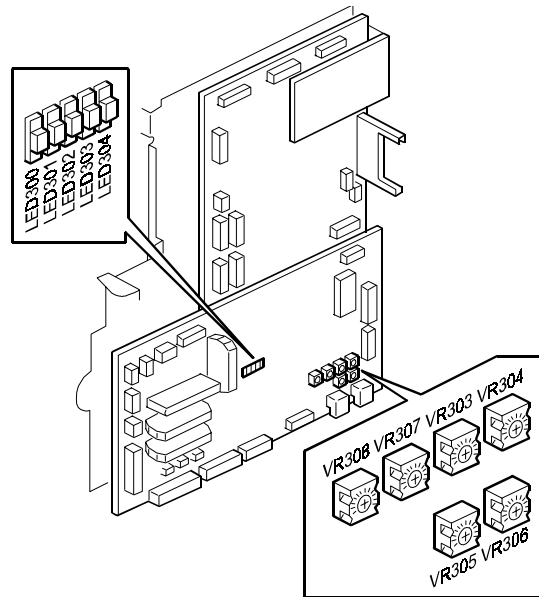

C235R016.WMF

### 6.7.9 PLATEN RELEASE CAM ADJUSTMENT

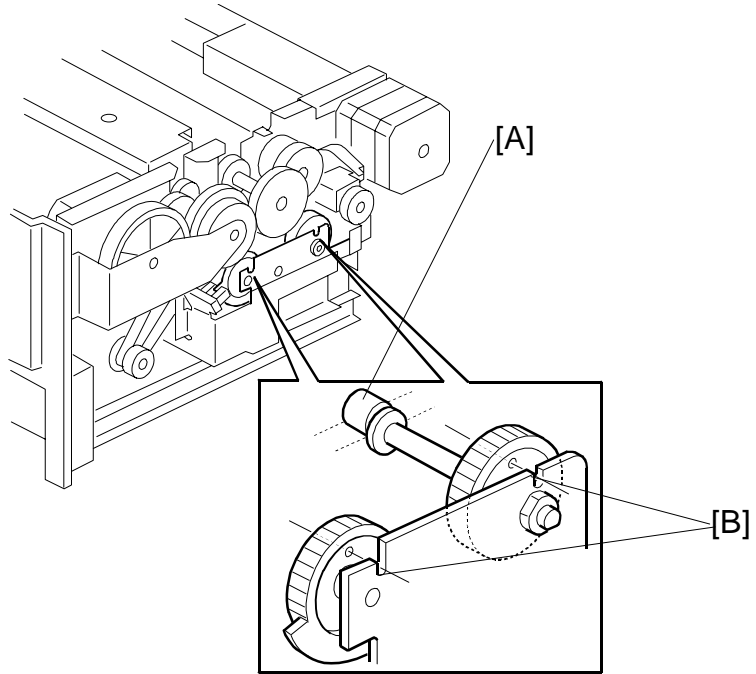

C235R017.WMF

**PURPOSE:** Once the platen pressure release mechanism is disassembled, the platen release cam [A] must be reinstalled in the correct position.

**PROCEDURE:**

When tightening the screws to secure the mechanism, make sure that the small holes in the gears [B] are in line with the cutouts in the bracket, as shown.

Replacement  
Adjustment

**6.7.10 MASTER FEED MYLAR POSITIONING**

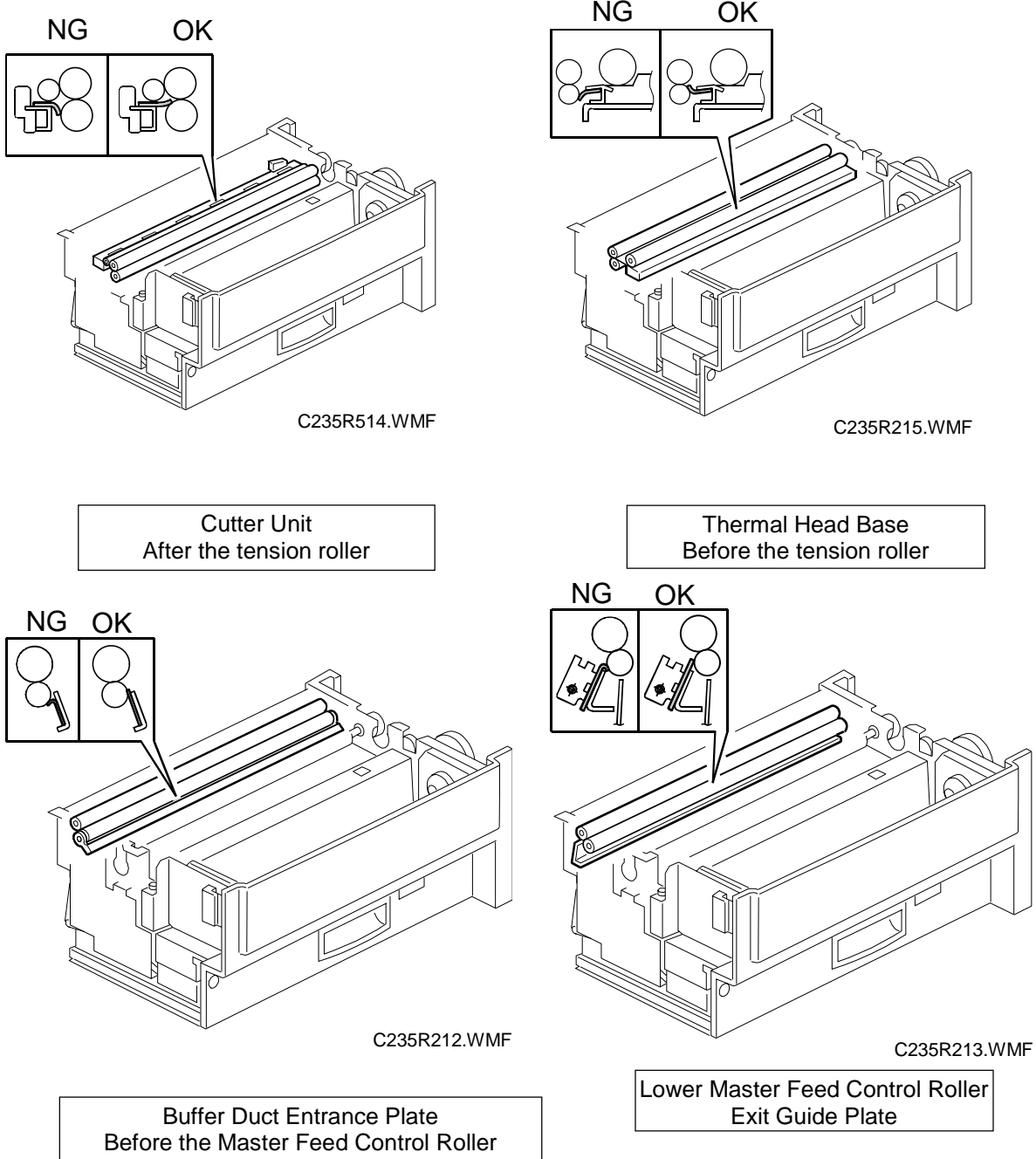

**PURPOSE:** These strips of mylar are easily put in the wrong position. Take care to set these properly to avoid master jams.

**PROCEDURE:**

When replacing or removing the thermal head, the cutter unit, the master duct, or the guide plate of the lower master feed control roller, install the lower tension roller or lower master feed control roller as shown in the illustration.



## 6.8 DRUM

### 6.8.1 DRUM CLOTH SCREEN

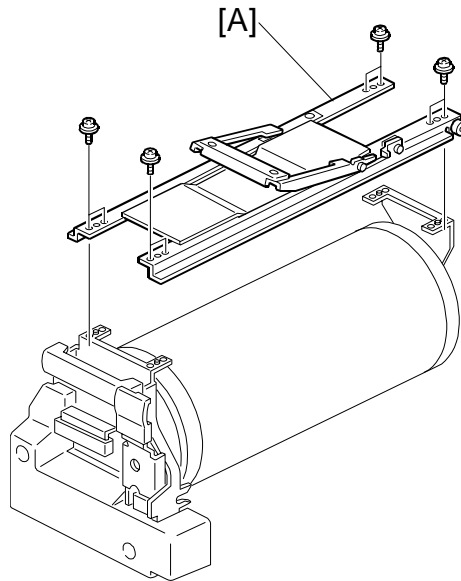

C235R145.WMF

1. Remove the drum guide [A].

**NOTE:** Do not settle the drum unit upside down. However, if you do settle it upside down, wipe off the ink around the ink roller beforehand (using SP 2-002-1, select OFF in ink detection mode, and feed paper until ink ends).

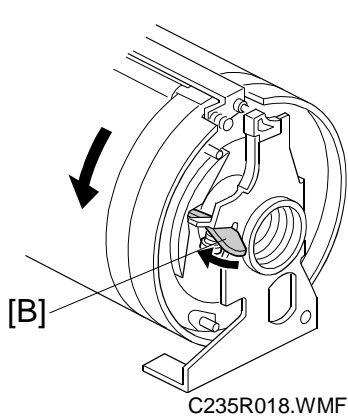

C235R018.WMF

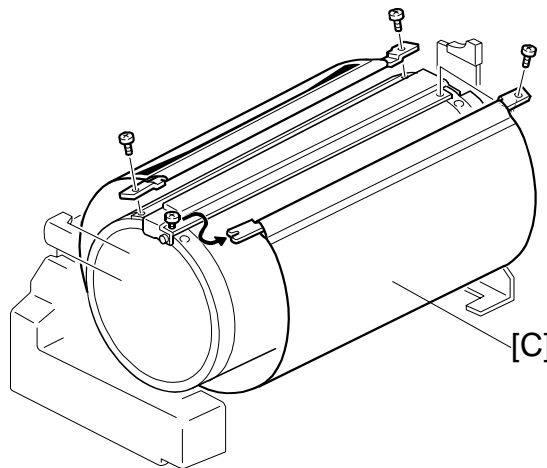

C235R501.WMF

2. Loosen the stopper [B], then rotate the drum until the clammer unit is positioned on the top of the drum.
3. Remove the drum screen [C].

Replacement  
Adjustment

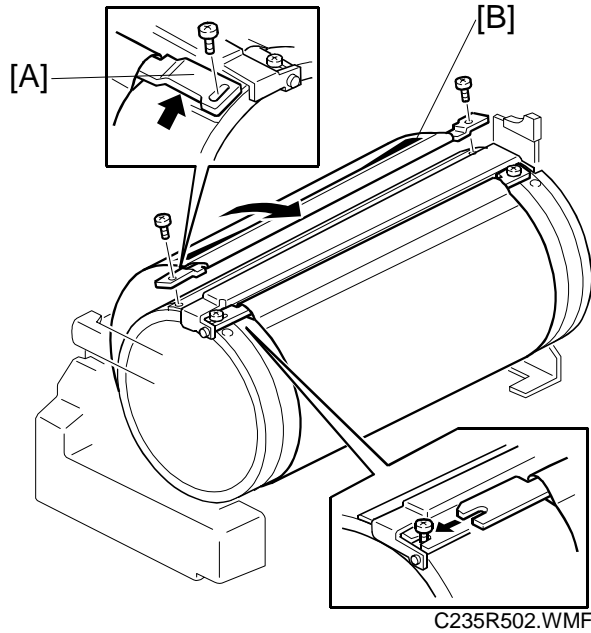

- CAUTION:**
- 1) Do not scratch the cloth screen or metal screen.
  - 2) When replacing the cloth screen, spread the screen around the metal screen while strongly pulling the stay [A]. Adjust the stay so that it is parallel to the master clamber, then tighten the screws.
  - 3) When installing the new screen, the black sensor patch [B] must be to the left of the master clamber. (Position the clamber on the top of the drum, and view from the operation side - refer to the above illustration.)
  - 4) Make sure that the correct side of the screen is facing up. (Refer to the illustration below.)
  - 5) Make sure that the stays for securing the cloth screen are positioned correctly. (Refer to the illustration below.)

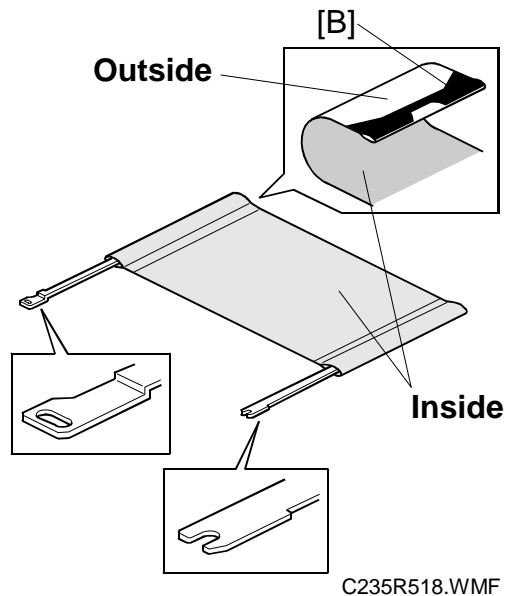

### 6.8.2 DRUM MASTER CLAMPER AND METAL SCREEN

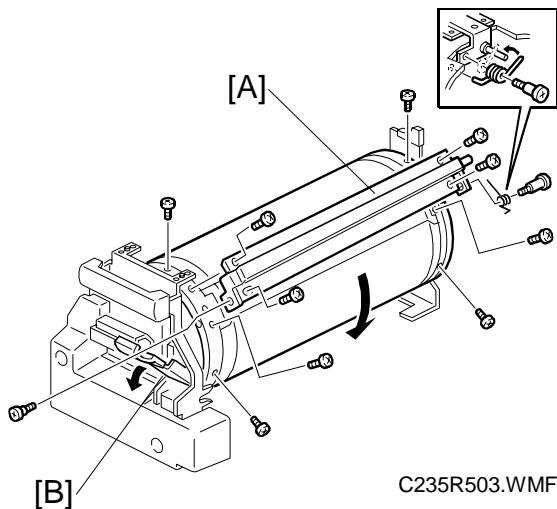

**NOTE:** Remove the cloth screen first.

1. Remove the drum clasper [A].

**NOTE:** To remove the clasper screws on the operation panel side, turn the drum into position and pull out the lever [B]. To rotate the drum, release the stopper [C] on the rear of the drum.

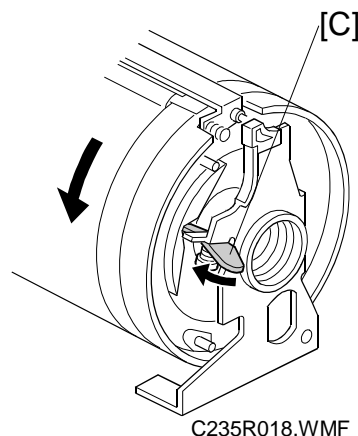

- CAUTION:**
- 1) When replacing the drum clasper, install the spring on the opposite side as shown in the illustration.
  - 2) Do not settle the drum unit upside down. However, if you do settle it upside down, wipe off the ink around the ink roller beforehand (using SP 2-002-1, select OFF in ink detection mode, and feed paper until ink ends).

Replacement Adjustment

2. Remove the metal screen [D].

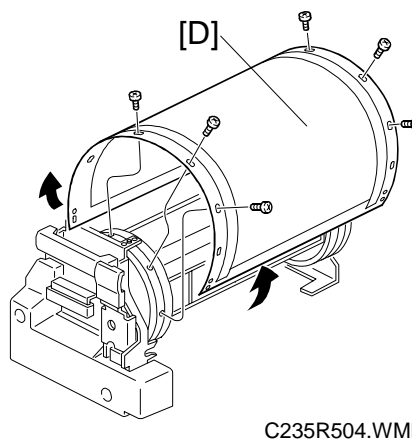

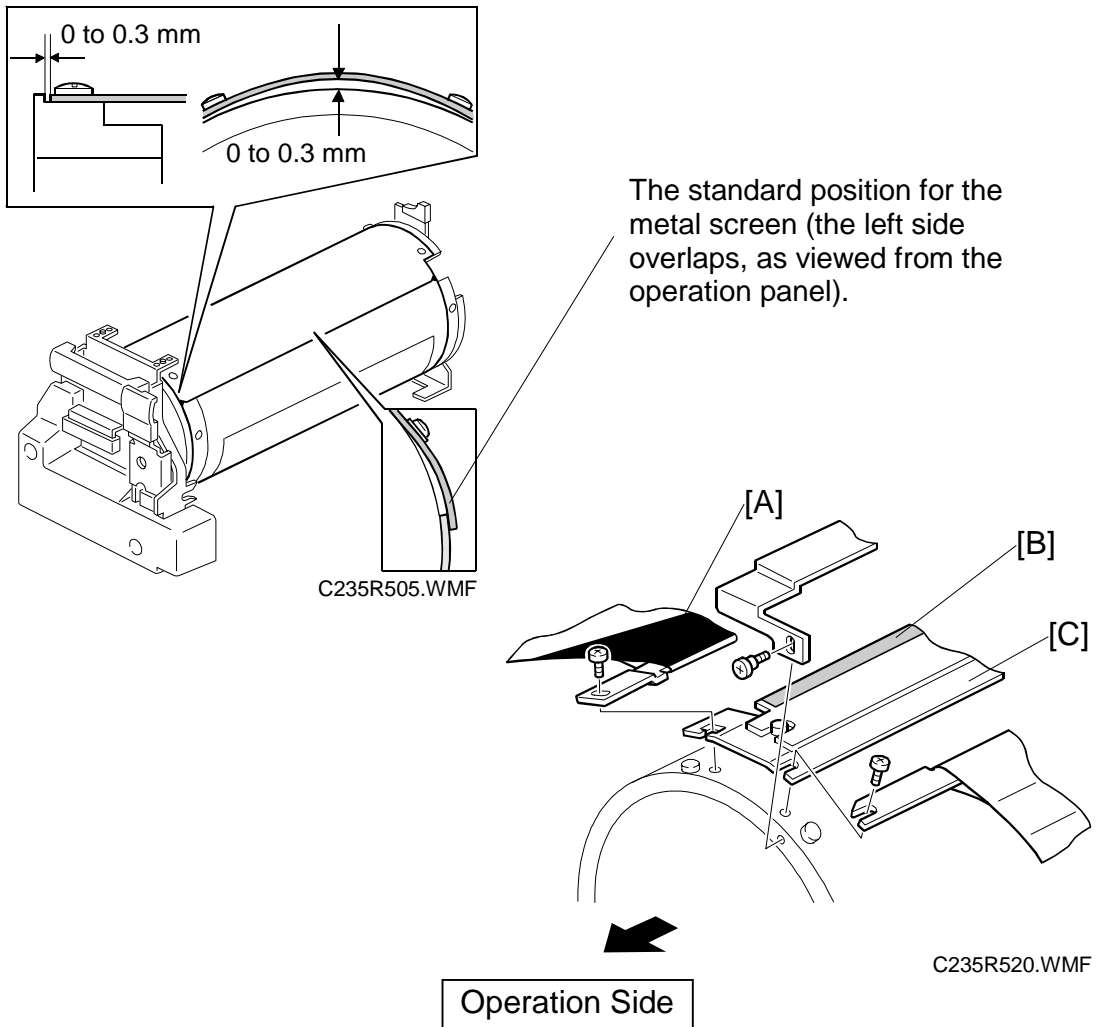

**CAUTION:**

- 1) Do not scratch the cloth screen or metal screen.
- 2) Make sure that the correct end of the metal screen is overlapping. (Refer to the lower right part of the upper illustration.)
- 3) When attaching the metal screen to the drum flanges, wrap it so that the gap is correct. (Refer to the upper part of the upper illustration.)
- 4) When installing the master clasper [C], make sure that it is the correct way around. The side with the sandpaper [B] must be facing the black patch [A].
- 5) Do not allow the inside of the master clasper to become dirty with ink. If it is dirty with ink, the master may slip off and the image position on the prints will move toward the trailing edge of the print during a printing run.
- 6) Use a cloth dampened with water to clean the inside of the master clasper. Do not use alcohol or other solvents. The clamping force of the magnet will be weakened.

### 6.8.3 MOTORS AND SENSORS IN THE DRUM

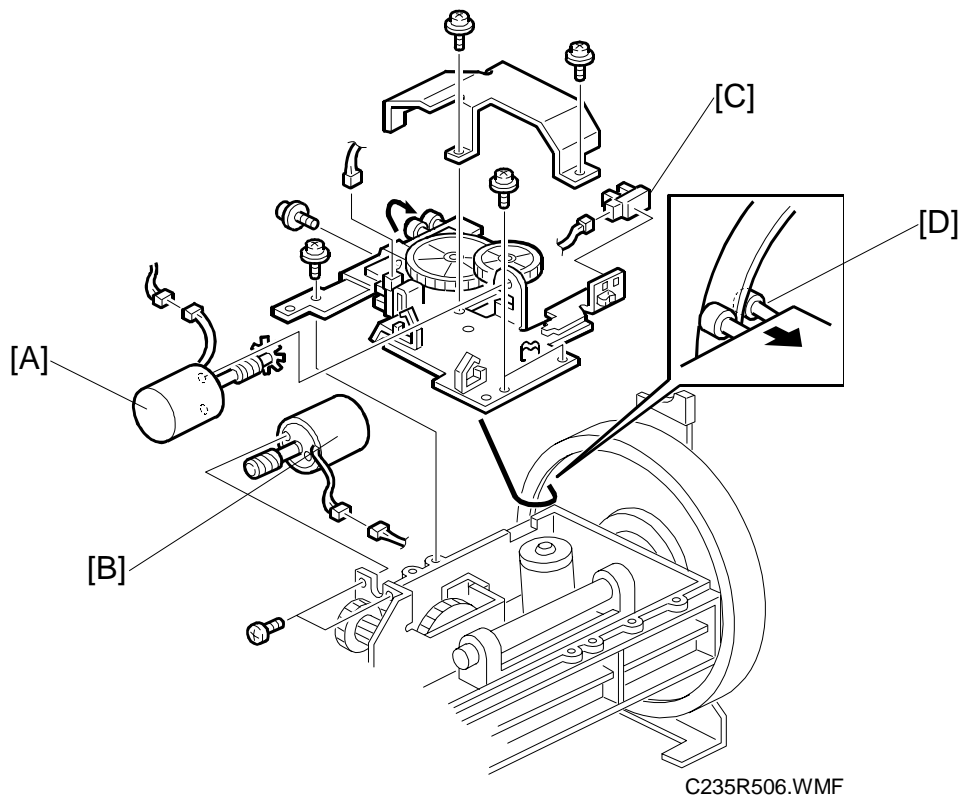

**NOTE:** Remove the cloth screen and metal screen first.

1. First, pull out the ink cartridge holder.  
A: Drum shift motor  
B: Ink pump motor  
C: Drum shift HP sensor

**NOTE:** When reinstalling the drum shift motor unit, insert the bearings [D] into the drum flange edge, as shown.

Replacement  
Adjustment

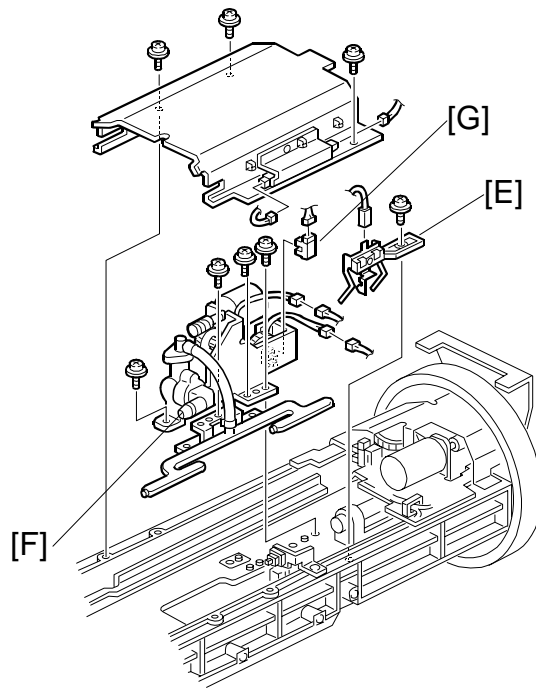

C235R521.WMF

- 2. E: Ink detection pin
- 3. First, remove the ink pump unit.  
F: Ink pump  
G: Ink pump sensor

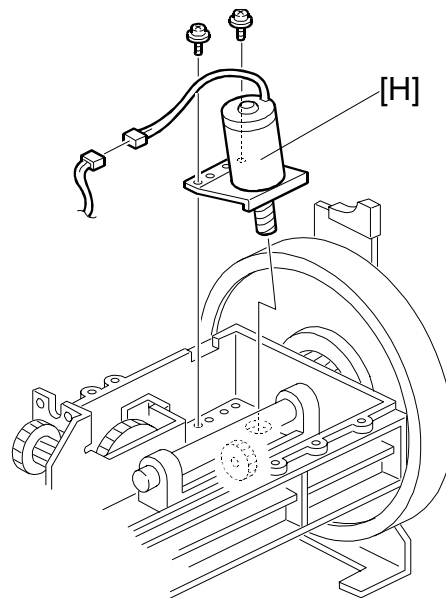

C235R508.WMF

- 4. H: Idling roller motor

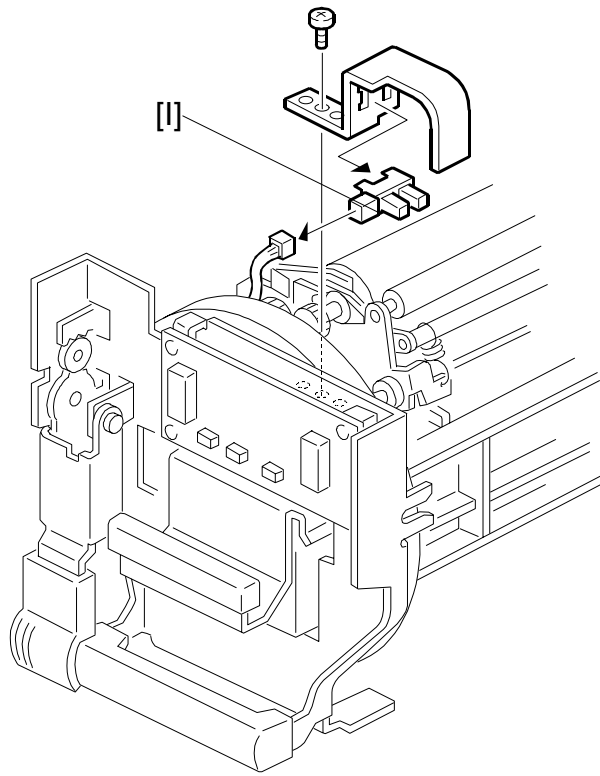

C235R154.WMF

5. First, remove the sensor bracket (1 screw).  
1: Idling roller HP sensor

Replacement  
Adjustment

**6.8.4 QUALITY BLADE**

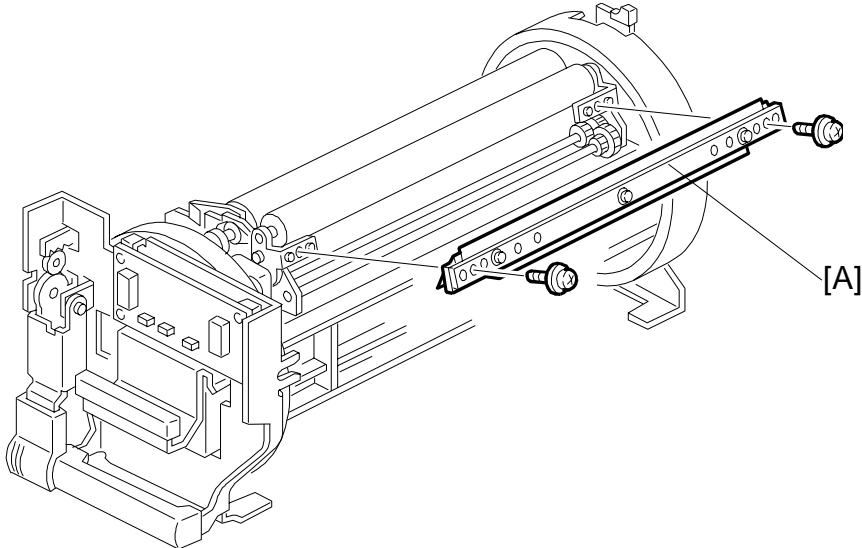

C235R019.WMF

A: Quality blade (2 screws).



## 6.8.5 FIRST DRUM MASTER SENSOR ADJUSTMENT

**PURPOSE:** To ensure that the sensor detects the master properly.

- CAUTION:**
- 1) The sensor adjustment is required in the following cases:
    - When the sensor is replaced.
    - When the I/O board is replaced.
  - 2) While adjusting, make sure to attach all exterior covers to avoid external light.
  - 3) Do not turn the VRs excessively.
  - 4) If the sensor is dirty, clean or replace it.
  - 5) For how to access the SP mode, refer to the Service Program Mode section.

### PROCEDURE:

1. Remove the master that is wrapped around the drum, and install the drum in the main body.
2. Turn on the main switch, then access SP6-004-2 (Sensor Voltage and Threshold Adjustment for 1st Drum Master Sensor).
3. Remove the rear cover and access the I/O board.
4. Adjust VR305 so that the sensor input voltage displayed on the operation panel becomes between 1.0 and 1.3 volts.
5. Leave the SP mode.

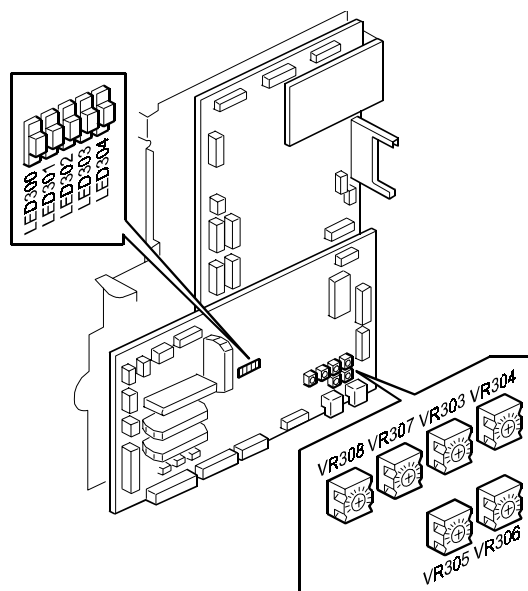

C235R016.WMF

Replacement  
Adjustment

## 6.8.6 SECOND DRUM MASTER SENSOR ADJUSTMENT

**PURPOSE:** To ensure that the sensor detects the master properly.

### PROCEDURE:

- CAUTION:**
- 1) The sensor adjustment is required in the following cases:
    - When the sensor is replaced.
    - When the I/O board is replaced.
  - 2) While adjusting, make sure to attach all exterior covers to avoid external light.
  - 3) Do not turn the VRs excessively.
  - 4) If the sensor is dirty, clean or replace it.
  - 5) For how to access the SP mode, refer to the Service Program Mode section.

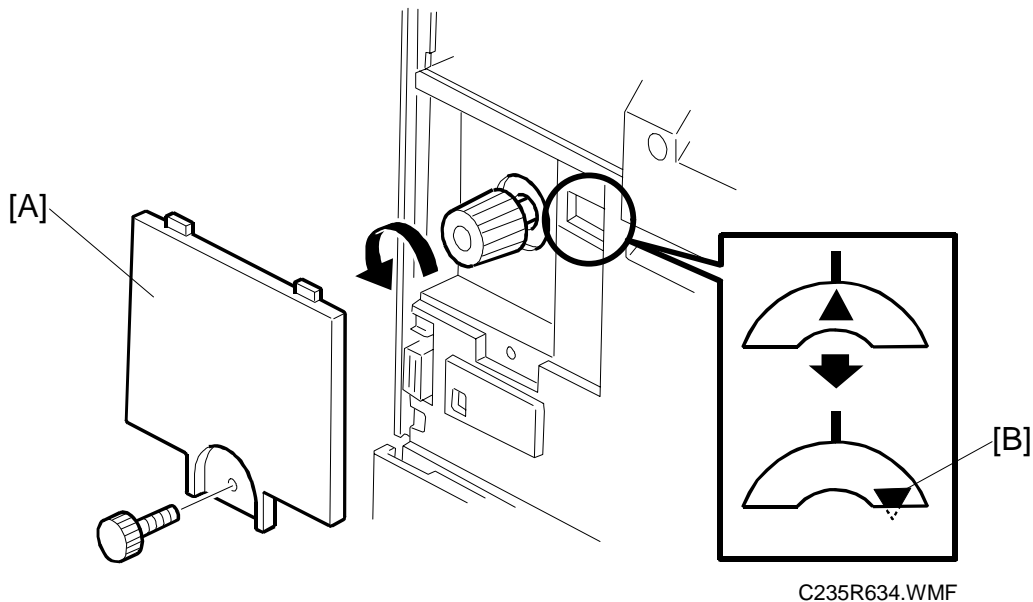

1. Remove the master that is wrapped around the drum, and install the drum in the main body.
2. Remove the knob cover [A] and turn the knob until the indicator moves to the point shown [B].

**NOTE:** This step moves the black patch on the drum screen to the sensor.

3. Remove the rear cover and access the I/O board.
4. Fully turn VR306 counterclockwise.  
**NOTE:** The sensor output becomes minimum.
5. Turn on the main switch, then access SP6-004-3 (Sensor Voltage and Threshold Adjustment for 2nd Drum Master Sensor).
6. The sensor input voltage is displayed on the operation panel. Check if it is 0.4 volts or more.
7. If the sensor input voltage is 0.4 volts or more, adjustment is completed.
8. If the sensor input voltage is less than 0.4 volts, adjust VR306 so that the sensor input voltage becomes between 0.4 and 0.5 volts.
9. Leave the SP mode.

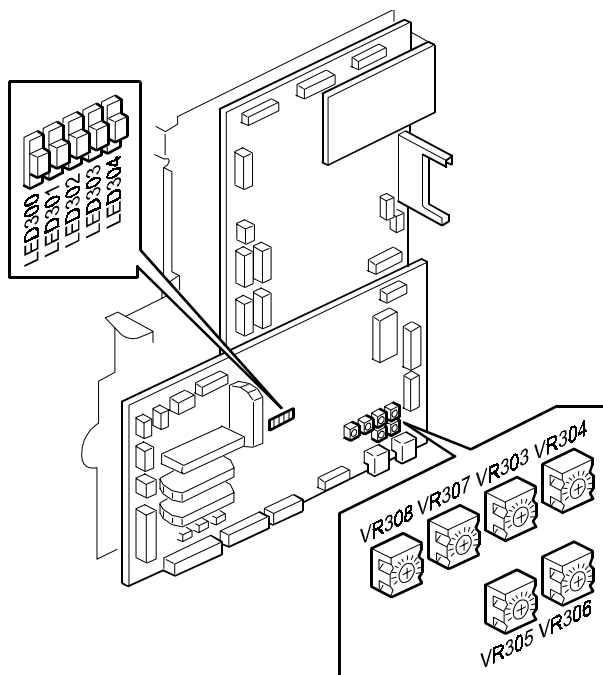

C235R016.WMF

Replacement Adjustment

### 6.8.7 INK ROLLER GAP ADJUSTMENT

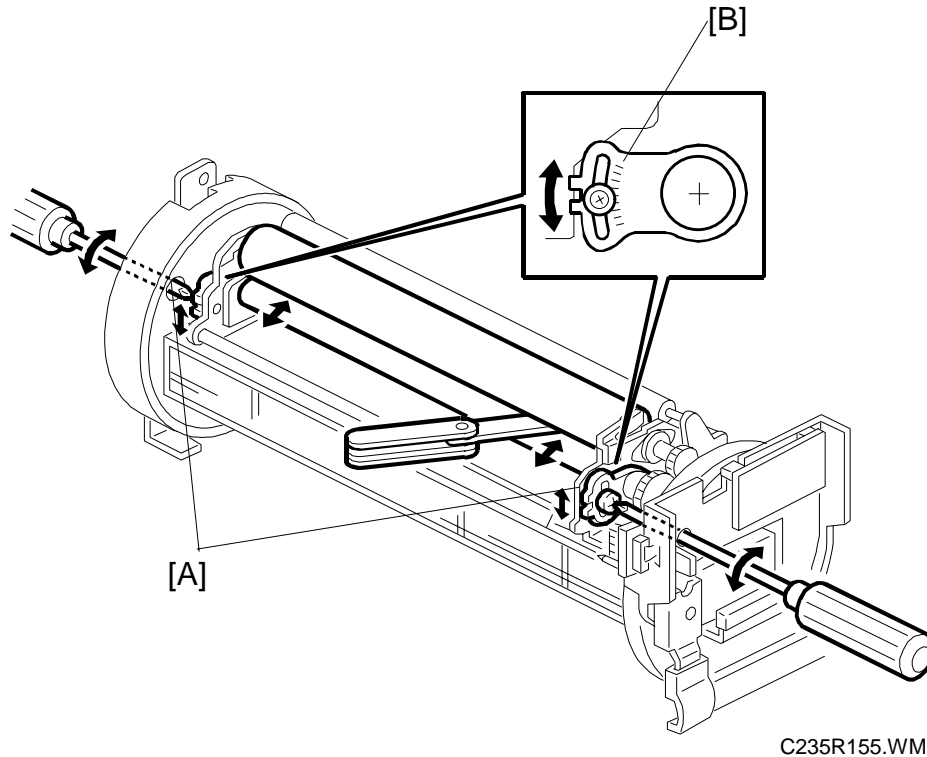

C235R155.WMF

**PURPOSE:** To ensure that ink on the ink roller spreads evenly on the drum screen.

**PROCEDURE:**

1. Take out the drum unit from the machine.
2. Remove the cloth and metal screens from the drum unit.
3. Wipe off the ink around the ink roller and the doctor roller.
4. Insert a 0.08-mm gap gauge between the doctor roller and the ink roller. Then, make sure that a 0.1-mm gauge cannot pass through the gap.

**NOTE:** Check the gap at the left, center, and right.

5. If the gap is not correct, loosen the screws [A] on both sides and adjust the gap by turning the eccentric bushings [B] at each side.

### 6.8.8 INK DETECTION ADJUSTMENT

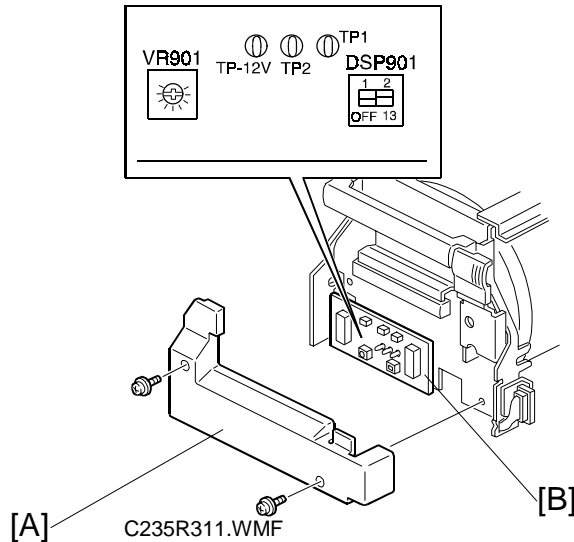

**PURPOSE:** To ensure correct detection of a no ink condition when all the ink has been consumed.

**NOTE:** For this adjustment, there must be no ink on the ink roller.

**PROCEDURE:**

1. Remove the drum front cover [A].
2. On the ink detection board [B], connect the probes and the grounding lead of an oscilloscope as follows:
  - Probe CH1 to TP1
  - Probe CH2 to TP2
  - Grounding lead to TP-12V  
(Select the 5  $\mu$ s range.)
3. Turn on the main switch.
4. Make sure that the waveform is as shown in the top half of the following diagram when the ink detection pin is not in contact with the ink.

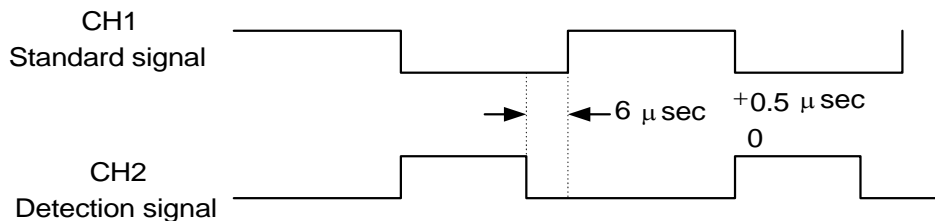

C235R182.WMF

5. If incorrect, adjust the standard signal by turning VR901 on the ink detection board.

Replacement Adjustment

## 6.9 PAPER FEED SECTION

### 6.9.1 PAPER TABLE UNIT

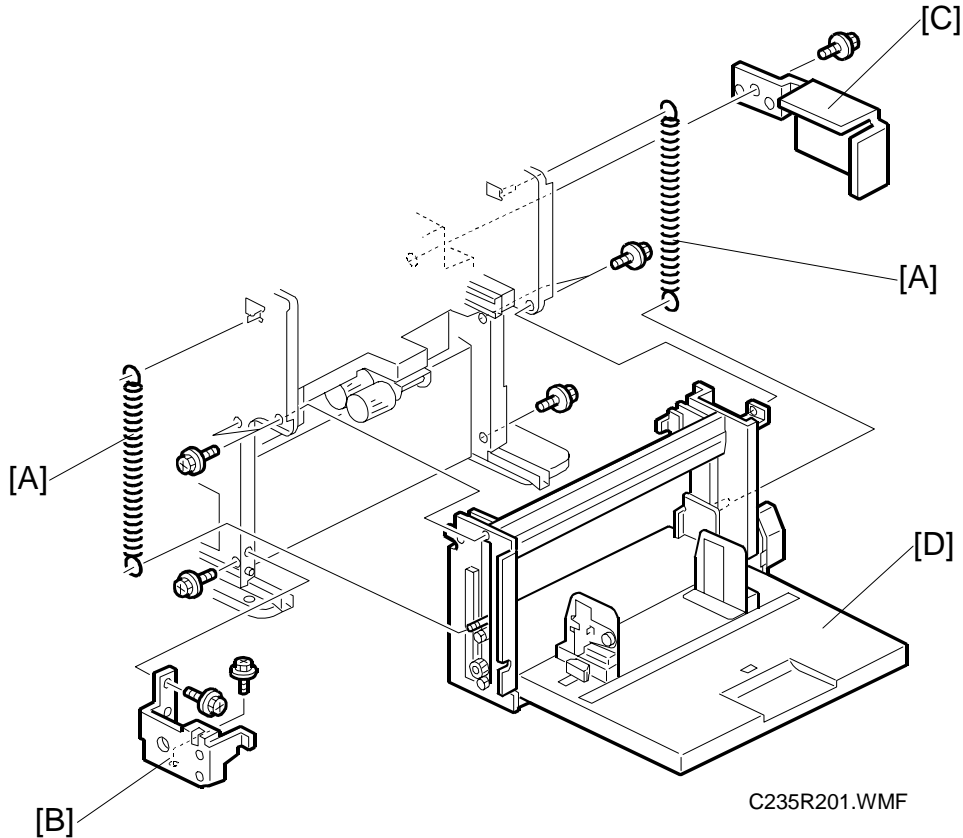

1. Remove the inner cover and the rear cove. (See 6.1 Exterior section.)
2. From the rear of the machine, swing out the MPU. (See 6.4 MPU and PSU Opening Procedures.)
3. Remove the following parts:
  - A: Two springs
  - B: Front bracket (2 screws)
  - C: Rear bracket (1 screw)
4. Disconnect 4 connectors going to the unit, then remove the paper table unit [D] (6 screws).

### 6.9.2 PAPER FEED ROLLER, PICK-UP ROLLER, AND FRICTION PAD

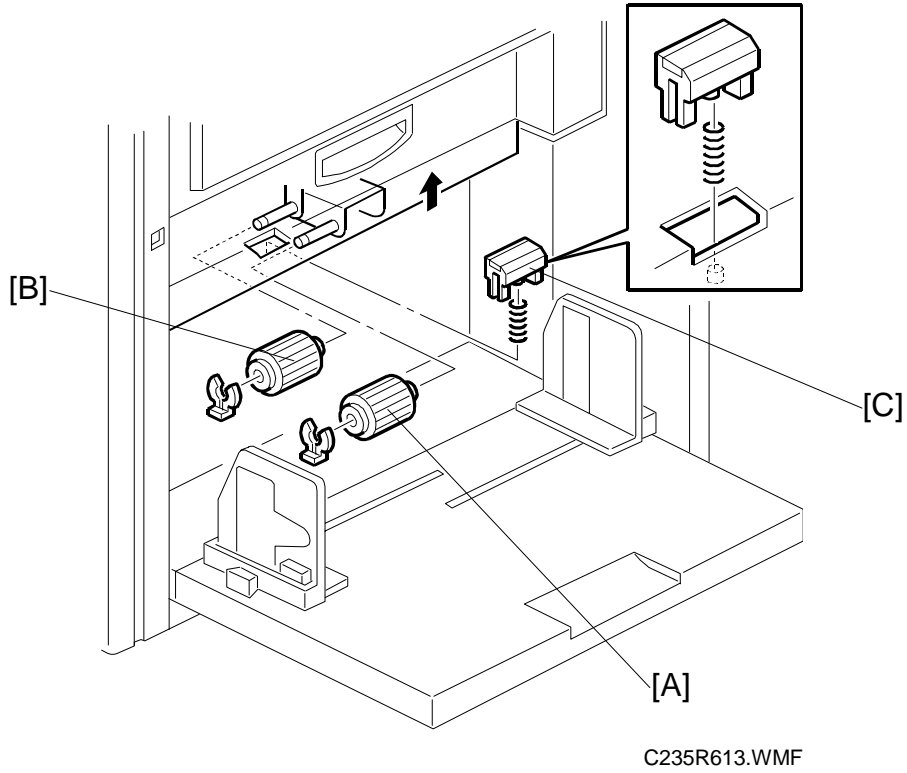

- A: Pick-up roller (1 clip)
- B: Paper feed roller (1 clip)
- C: Friction pad

Replacement  
Adjustment

### 6.9.3 PAPER WIDTH DETECTION BOARD

A: Paper table rear cover (7 screws)

**NOTE:** Carefully push out the 3 hooks [B] with a screwdriver.

C: Sensor cover (2 screws)

D: Paper width detection board (1 screw, 1 connector)

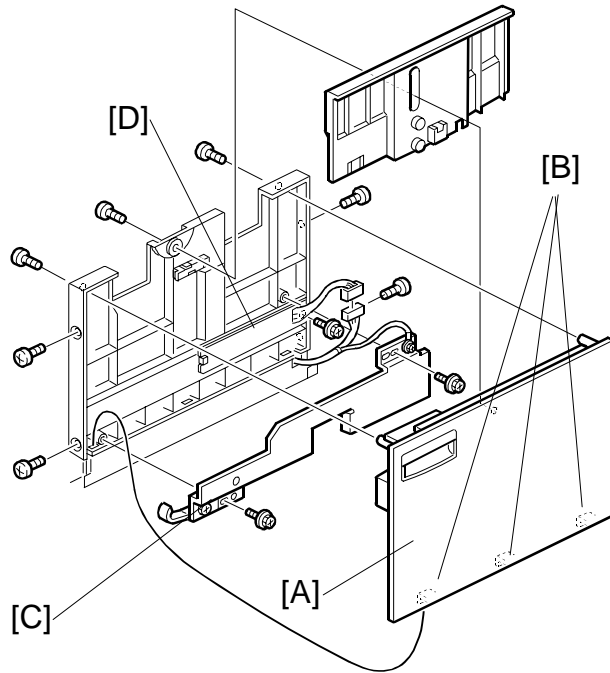

C235R509.WMF

### 6.9.4 PAPER HEIGHT SENSOR

First, remove the master making unit (see 6.7.1 Master Making Unit Removal).

A: Feed cover (2 screws)

B: Paper height sensor (1 screw, 1 connector)

**NOTE:** When reinstalling the master making unit, push it in while pressing the rail with a forefinger. Then secure the screws.

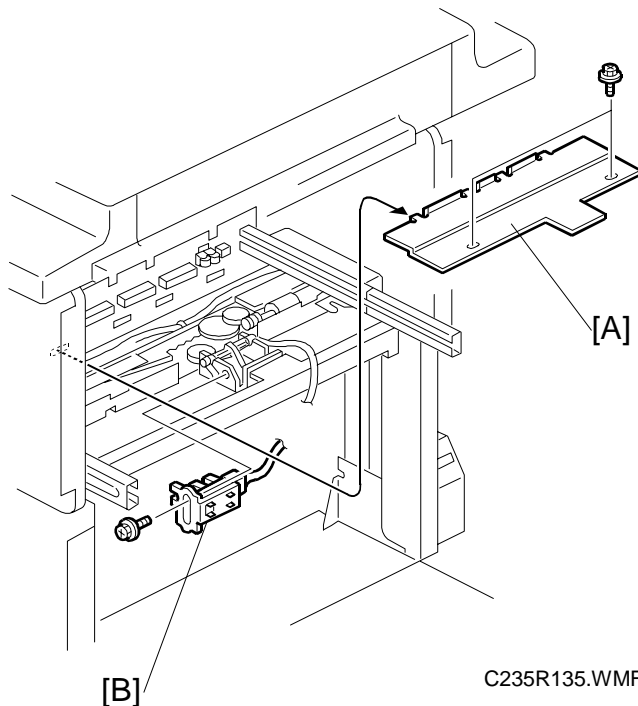

C235R135.WMF



### 6.9.5 FEED PRESSURE DETECTION BOARD

1. Remove the master making unit. (See 6.7.1 Master Making Unit Removal.)

A: Feed cover (2 screws)

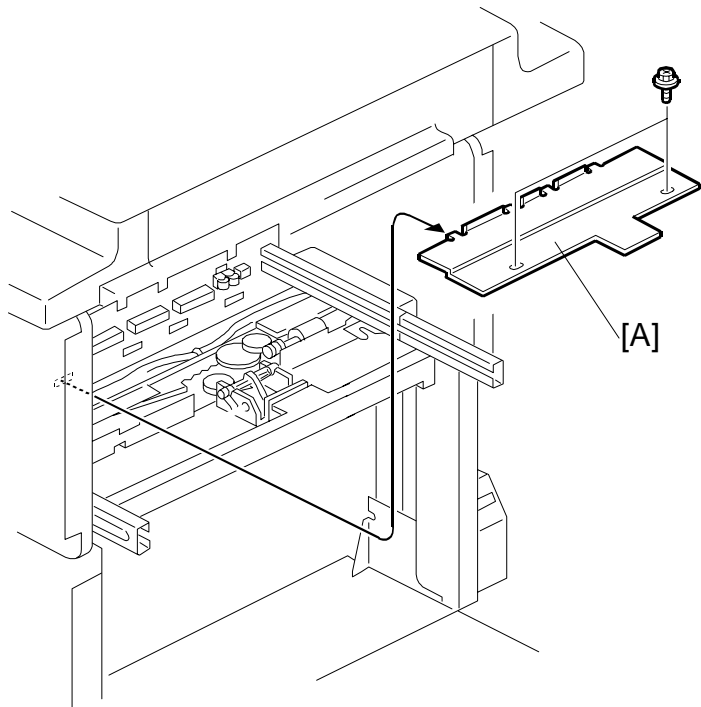

C235R600.WMF

2. Swing out the MPU. (See 6.4 MPU and PSU Opening Procedures.)

B: Rear rail guide  
C: Feed pressure detection board (2 screws)

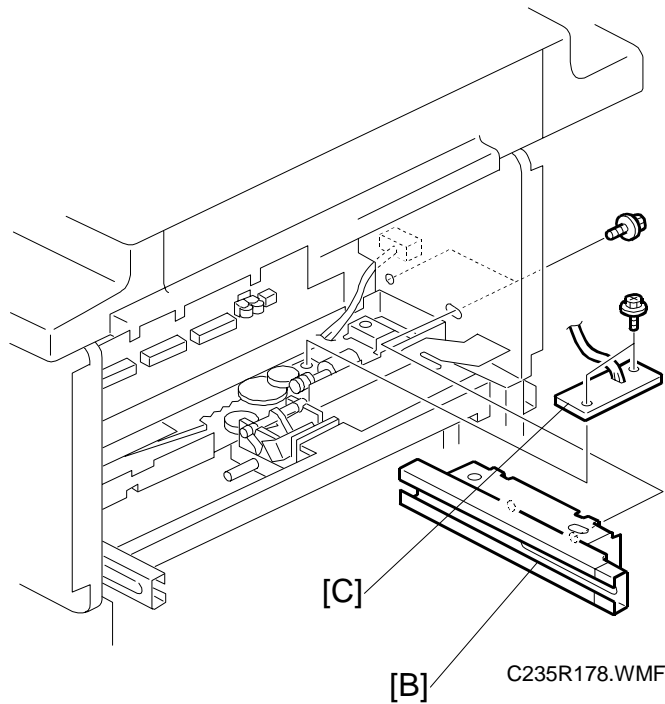

C235R178.WMF

### 6.9.6 PAPER REGISTRATION AND FEED TIMING SENSORS, AND UPPER REGISTRATION ROLLER

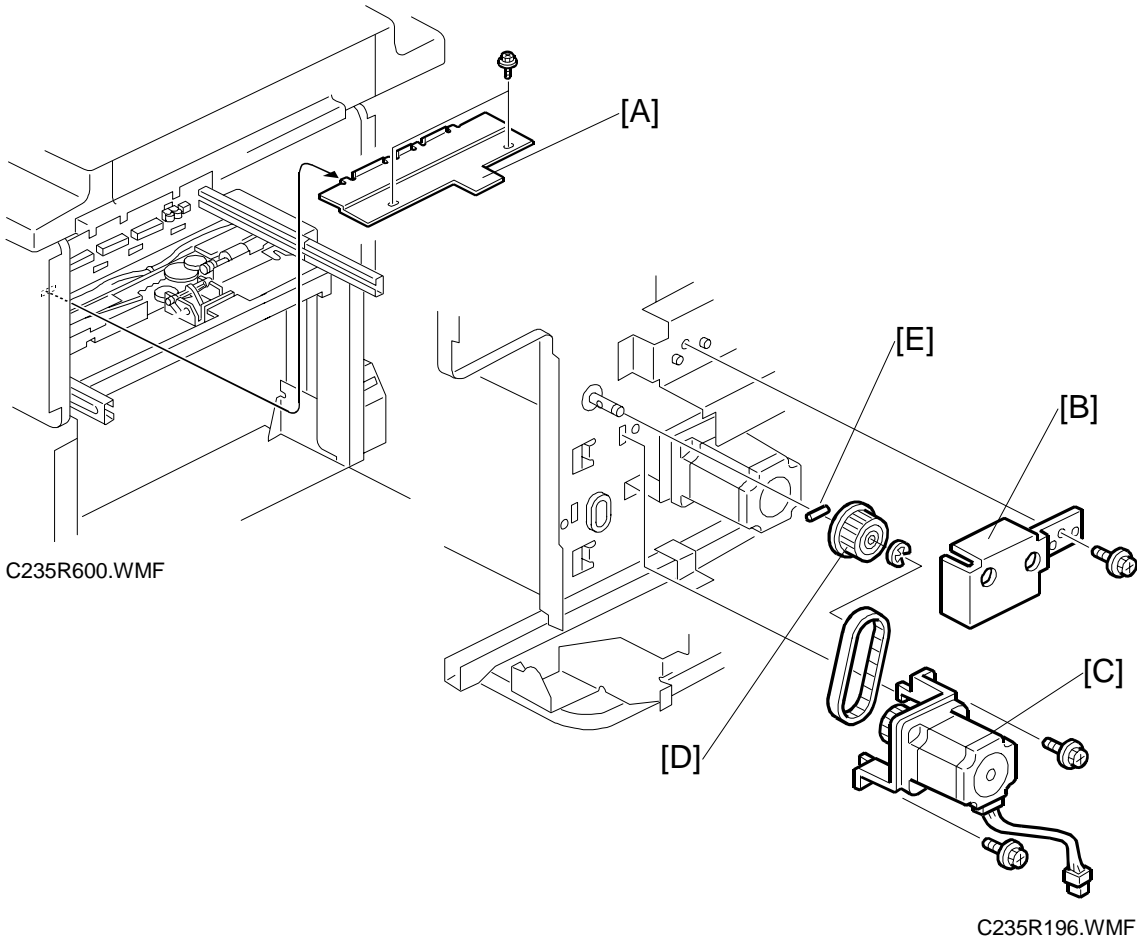

1. Remove the master making unit. (See 6.7.1 Master Making Unit Removal.)

A: Feed cover (2 screws)

2. Swing out the MPU. (See 6.4 MPU and PSU Opening Procedures.)

B: Pulley cover (1 screw)

C: Paper feed motor (2 screws)

D: Pulley (1 E-ring)

**NOTE:** Do not lose the key [E] from the pulley.

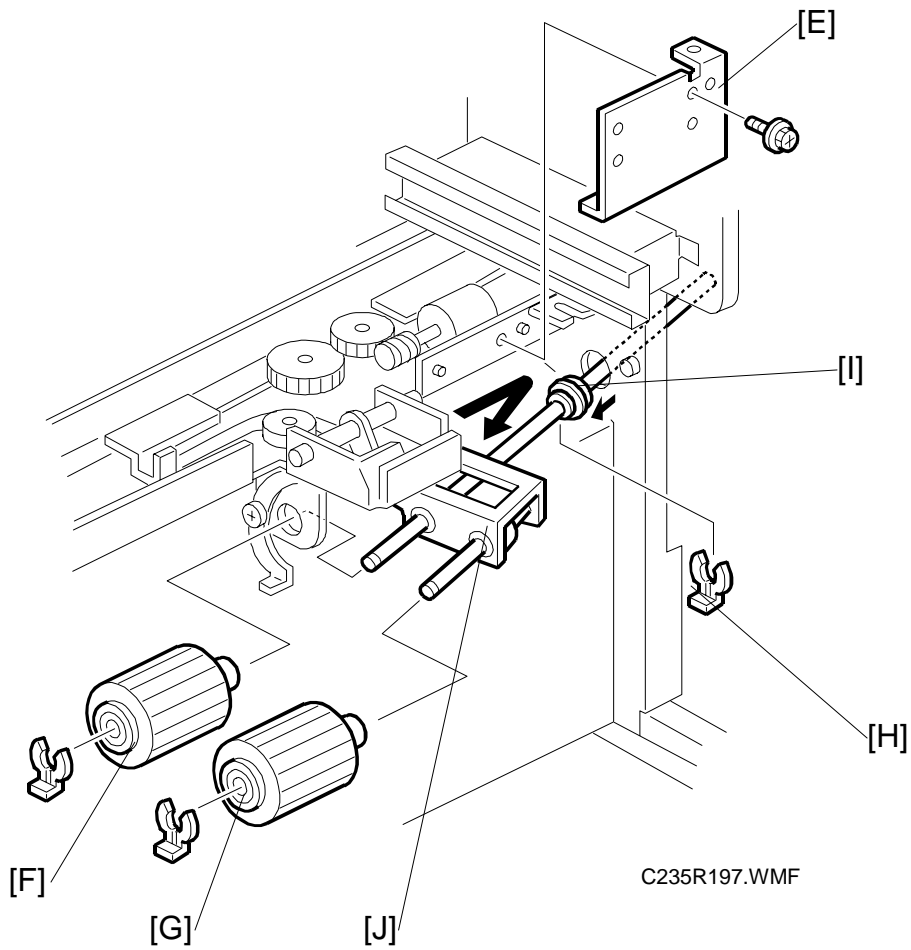

- 3. E: Right paper guide plate (1 screw)  
F: Paper feed roller (1 clip)  
G: Pick-up roller (1 clip)

- 4. Remove the clips [H] and slide the bushing [I] towards the operation side.

J: Paper feed roller unit

Replacement  
Adjustment

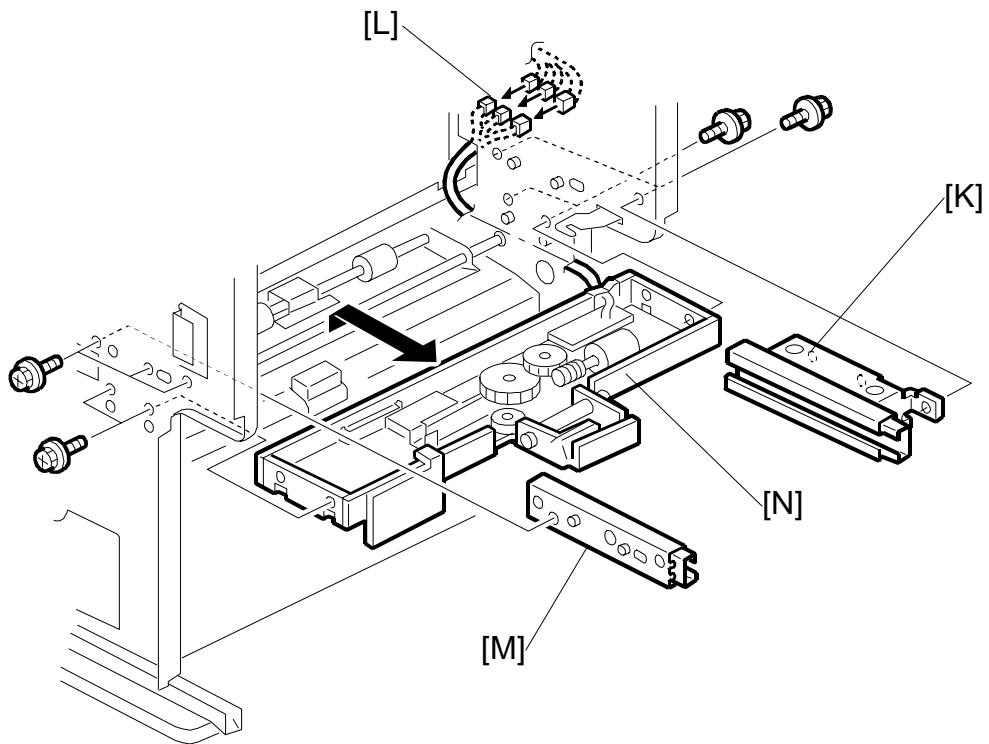

C235R198.WMF

5. K: Rear rail guide (2 screws)  
L: Connectors from the feed pressure detection board

6. Remove the front exterior cover and inner cover.

M: Front rail guide (2 screws)  
N: Feed pressure unit [C] (4 screws)

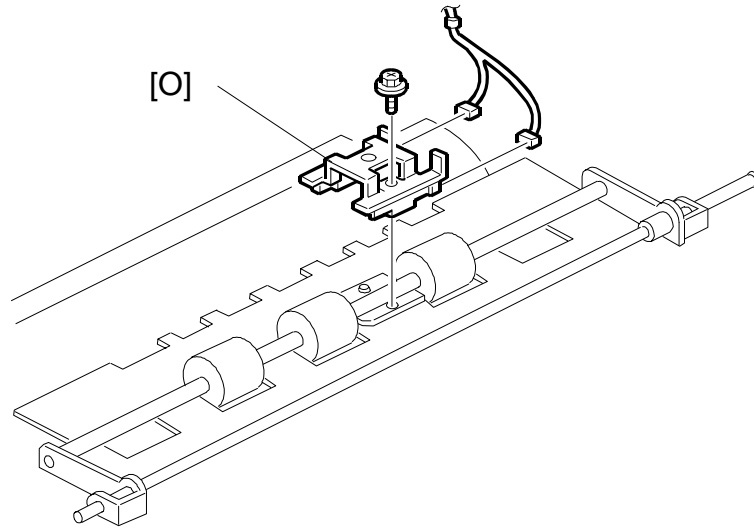

C235R136.WMF

7. O: Sensor bracket (1 screw).
8. Remove the paper registration and feed timing sensors from the bracket.

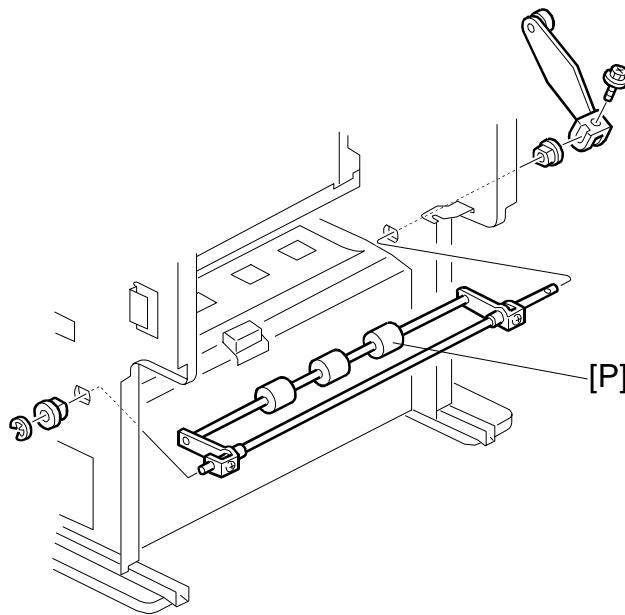

C235R627.WMF

9. P: Upper registration roller

Replacement  
Adjustment

### 6.9.7 LOWER REGISTRATION ROLLER

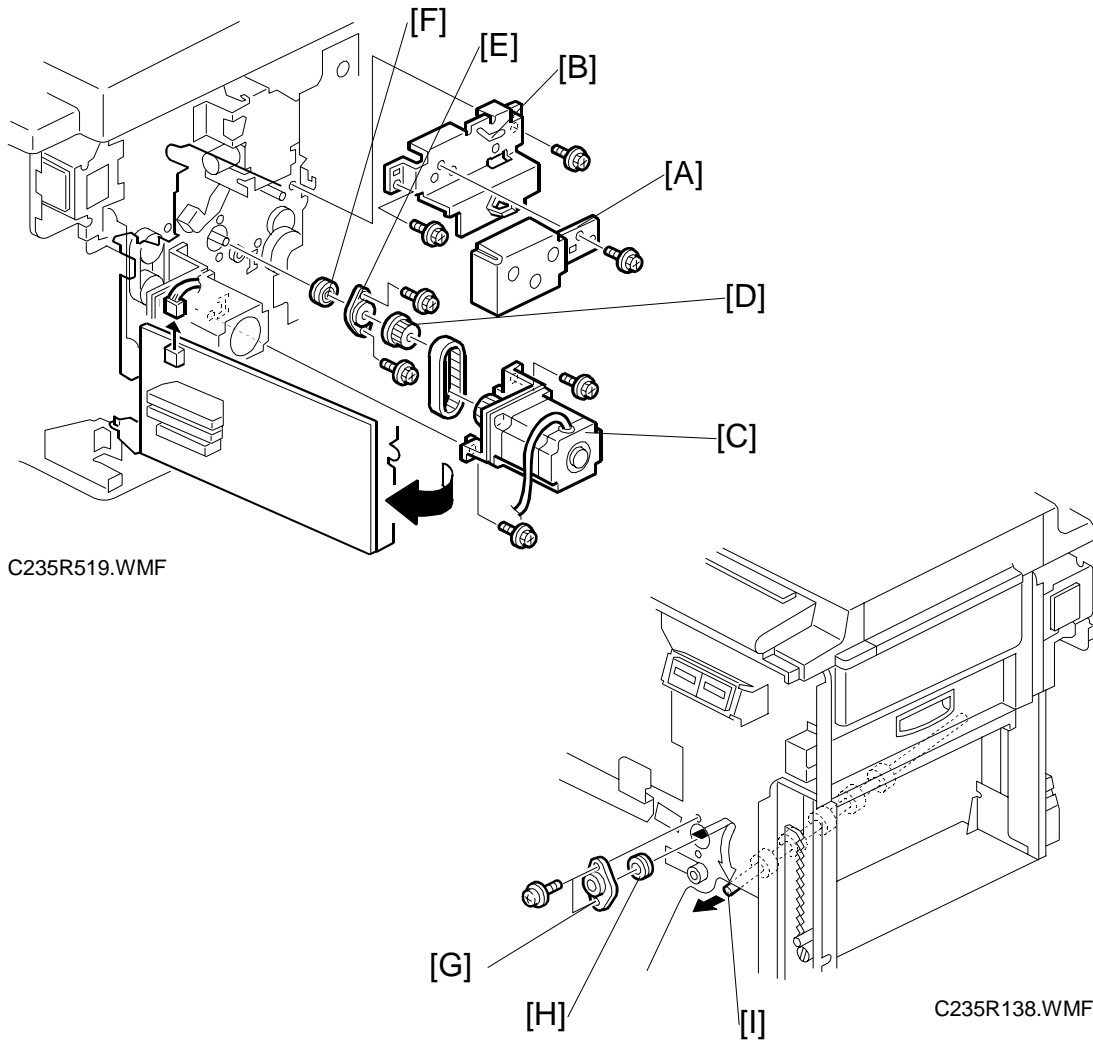

**- From the rear -**

1. Swing out the MPU. (See 6.4 MPU and PSU Opening Procedures.)
2. Remove the pulley cover [A] and the bracket [B] (3 screws, 7 connectors).
3. Remove the registration motor [C] (2 screws, 1 connector).
4. Remove the pulley [D] (2 Allen screws).
5. Remove the bearing holder [E] and the bearing [F] (2 screws).

**-From the front -**

6. Remove the front exterior cover (4 screws) and the inner cover (5 screws).
7. Remove the bearing holder [G] and the bearing [H] (2 screws).
8. Pull out the registration roller [I] towards the operation side.

## 6.9.8 REGISTRATION ROLLER LIFTING CAM REMOVAL

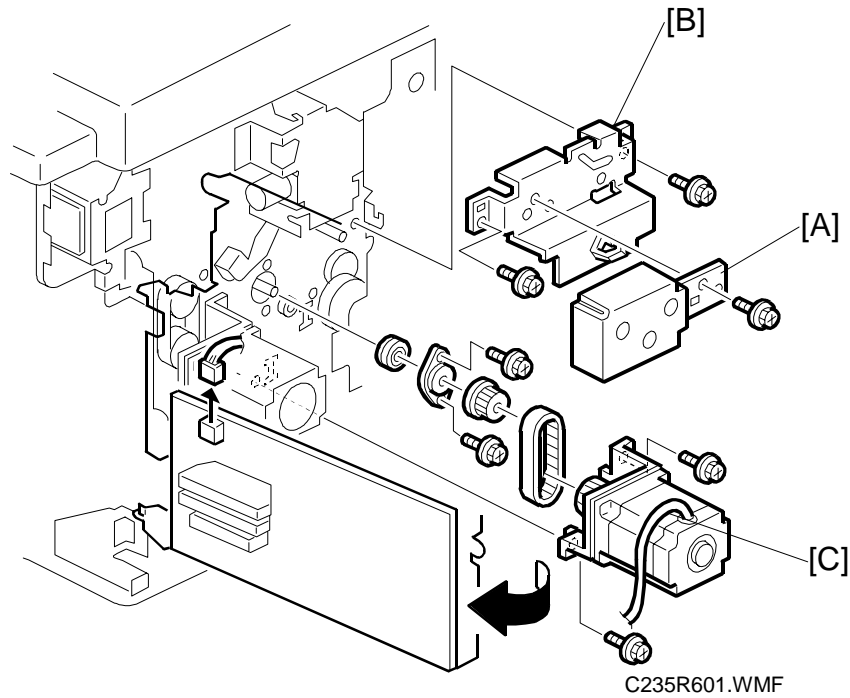

1. Swing out the MPU. (See 6.4 MPU and PSU Opening Procedures.)
2. Remove the pulley cover [A] and the bracket [B] (3 screws, 7 connectors).
3. Remove the registration roller lifting cam [C].

**CAUTION:** There is the set position for the cam. When reinstalling the cam, follow Registration Roller Lifting Cam Position Adjustment on the next page.

Replacement  
Adjustment

### 6.9.9 REGISTRATION ROLLER LIFTING CAM POSITION ADJUSTMENT

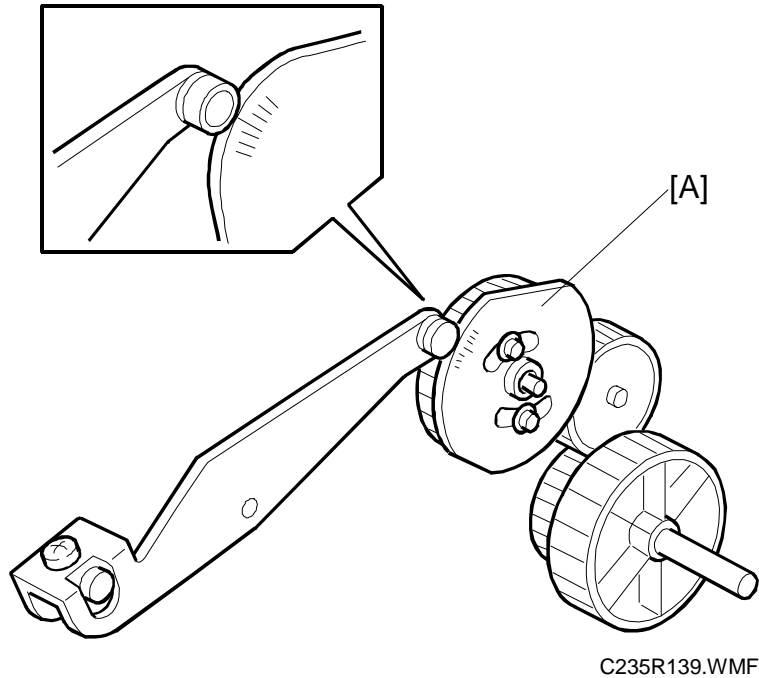

**PURPOSE:** To ensure smooth paper feed from the registration roller to the drum.

**CAUTION:** Make sure that the drum is at home position before the adjustment.

1. When installing the registration roller lifting cam [A] on the shaft, align the cam follower (a bushing) at the center or within two divisions to the right of the center.
2. If the cam follower cannot be put in the correct place, try to change the gear meshing. Also, try to readjust the position by loosening the screw holding the cam to the gear.

**NOTE:** To obtain a perfect adjustment, you must take out any gear play by applying clockwise pressure to the cam (with the gear) during the adjustment.



## 6.9.10 PAPER TABLE HEIGHT ADJUSTMENT

**PURPOSE:** To ensure smooth paper feed

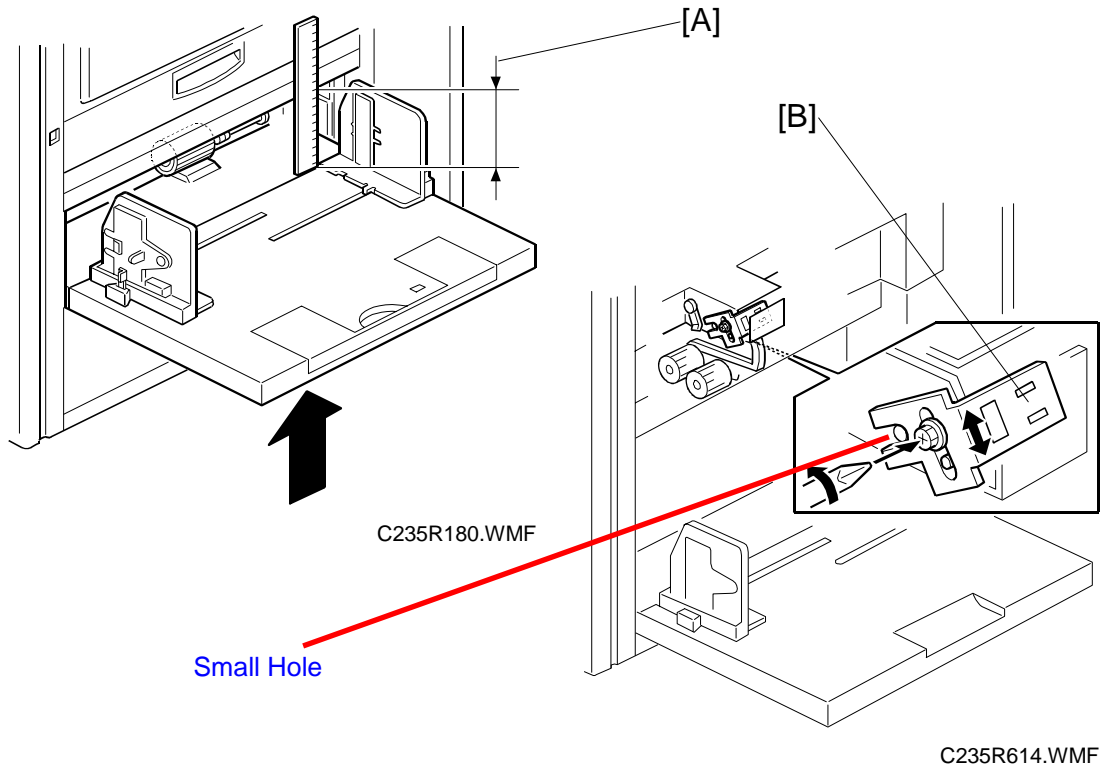

1. Open the paper table. (There must be no paper.)
2. Turn on the main switch, then access SP 5-030-1 ("Paper Table Motor Up" in the output test mode).
3. In the SP mode, hold down the Start key to lift the paper table until it stops.
4. After the paper table stops, check if the distance [A] between the lower edge of the stay and the upper face of the table until it is 76.5 mm.
5. If the distance is not correct, adjust the upper limit position of the paper table by changing the paper height sensor position. To do this, loosen the screw and moves the sensor bracket [B] up or down.

**NOTE:** 1) - To lower the stop position of the paper table: Moves the bracket down.  
 2) - To raise the stop position of the paper table: Moves the bracket up.

Replacement  
Adjustment

### 6.9.11 TIMING BELT TENSION ADJUSTMENT FOR THE PAPER FEED MOTOR

**PURPOSE:** To ensure smooth paper feed

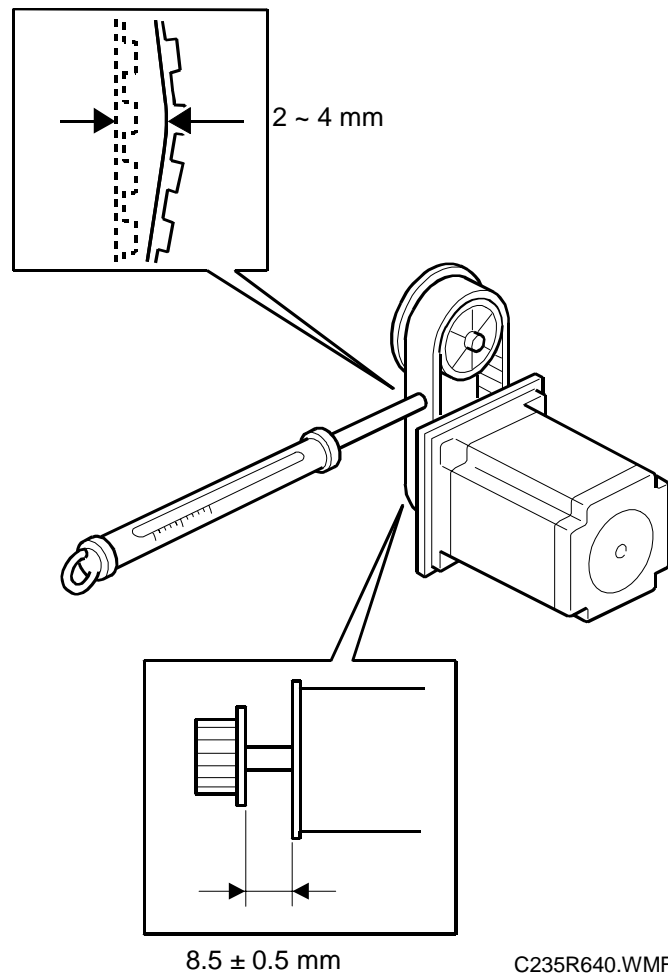

1. Make sure that the distance between the motor and the flange is  $8.5 \pm 0.5$  mm.
2. Apply a 500g load to the center of the belt using a tension gauge. Make sure that the belt deflects between 2 to 4 mm. If the tension is incorrect, move the motor up or down.

### 6.9.12 TIMING BELT TENSION ADJUSTMENT FOR THE REGISTRATION MOTOR

**PURPOSE:** To ensure smooth paper feed.

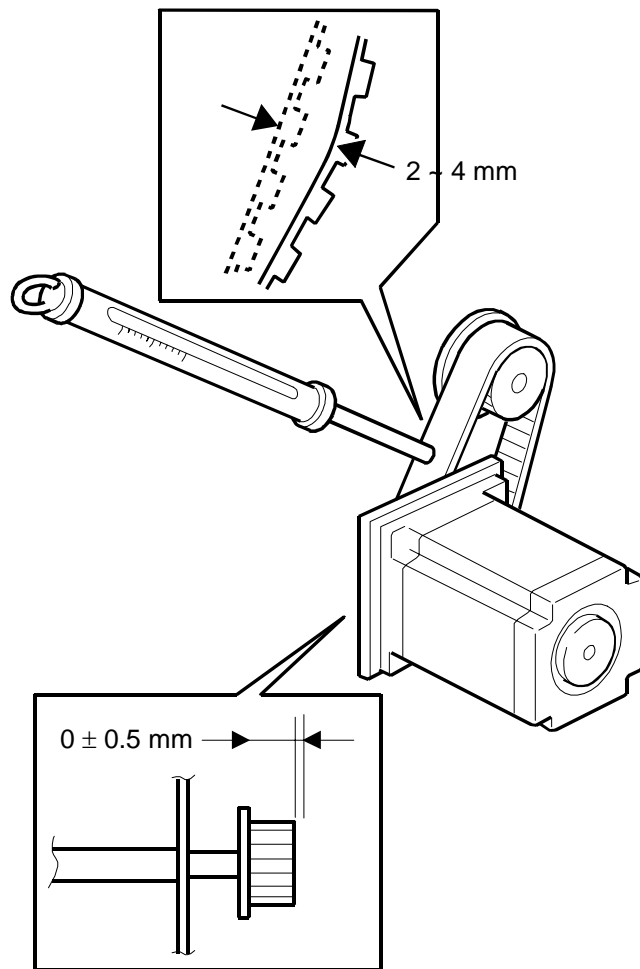

C235R639.WMF

1. Make sure that the distance between the end of the lower registration roller shaft and the edge of the pulley is  $0 \pm 0.5$  mm.
2. Apply a 500g load to the center of the belt using a tension gauge. Make sure that the belt deflects between 2 to 4 mm. If the tension is incorrect, move the motor up or down.

Replacement  
Adjustment

### 6.9.13 PAPER FEED AND SEPARATION PRESSURE ADJUSTMENT

#### *Paper feed pressure adjustment*

**PURPOSE:** To ensure smooth paper feed from the paper table.

- The user has a choice of three different settings for the paper feed pressure (Standard, Frequent, Very Frequent). The user sets this between jobs depending on how often they think no-feed errors are occurring.
  - The setting is returned to the default by pressing the Clear Modes key or turning the main switch off and back on. The default setting is "Standard".
  - The pressure applied for each setting can be adjusted by SP mode.
1. Select SP mode "6-009-1", "6-009-2" and "6-009-3".  
**NOTE:** SP6-009-10, 11, 12 are for special paper types (basically for envelopes), SP6-009-1, 2, 3 are for standard paper types, and SP6-009-4, 5, 6 are for thick paper. If the user has programmed as User 1 or User 2, you can change the paper feed pressures with SP6-009-13, 14, 15 and SP6-009-16, 17, 18.
  2. Change the settings as necessary.
    - Defaults for SP6-009-1 (Standard): 3, SP6-009-2 (Frequent): 5, SP6-009-3 (Very Frequent): 6
    - The available pressure levels are from 0 to 6. (0 is the weakest, 6 is the strongest.)

***Paper separation pressure adjustment***

**PURPOSE:** To ensure paper separation.

- The user has a choice of three different settings for the separation pressure (Standard, Frequent, Very Frequent). The user sets this between jobs depending on how often they think multi-feed errors are occurring.
  - The setting is returned to the default by pressing the Clear Modes key or turning the main switch off and back on. The default setting is “Standard”.
  - The pressure applied for each setting can be adjusted by SP mode.
1. Select SP mode “6-010-1”, “6-010-2” and “6-010-3”.  
**NOTE:** SP6-010-10, 11, 12 are for special paper types, SP6-010-1, 2, 3 are for standard paper types, and SP6-010-4, 5, 6 are for thick paper. If the user has programmed as User 1 or User 2, you can change the paper feed pressures with SP6-010-13, 14, 15 and SP6-10-16, 17, 18.
  3. Change the settings as necessary.
    - Defaults for SP6-010-1 (Standard): 4, SP6-010-2 (Frequent): 5, SP6-010-3 (Very Frequent): 6
    - The available pressure levels are from 0 to 6. (0 is the weakest, 6 is the strongest.)

## 6.9.14 PAPER FEED LENGTH ADJUSTMENT

### *Paper Feed Motor Stop Timing Adjustment*

**PURPOSE:** To ensure that the paper reaches the registration roller properly.  
Changing the paper feed motor stop timing with SP6-023-5 changes the paper feed length for the paper feed roller.

**CAUTION:** Do not change SP6-014 and 6-015 (these change the paper feed start timing).

### **PROCEDURE:**

1. Turn on the main switch, then access the SP mode.
2. Enter SP6-023-5.
3. Increase or decrease the value on the display.  
**NOTE:** 1) Before changing the value, check the current setting, in case you need to recover the previous setting. (Default for SP6-023-5 – "25")  
2) Changing the value by +1 increases the paper feed motor's on-time and feeds the paper an extra 0.3 mm.
4. Leave the SP mode, then check the paper feed performance. If the problem still occurs, repeat the above steps.

### ***Paper Clamping Timing Adjustment***

**PURPOSE:** To ensure that the paper reaches the paper clamber on the pressure cylinder properly. Changing the paper clamping timing with SP6-023-1 changes the paper feed length for the paper registration roller.

**CAUTION:** Do not change SP6-016 to 6-020 (these change the registration motor start timing). In addition, do not change SP6-023-3, -4, -6, or -7.

#### **PROCEDURE:**

1. Turn on the main switch, then access the SP mode.
2. Enter SP6-023-1.  
**NOTE:** The paper clamping timing depends on the paper type selected at the operation panel. SP6-023-1 is the adjustment for normal paper only. For thick paper, use SP6-023-2. (Note that in thick paper mode, paper clamping is not done.)
3. Increase or decrease the value on the display.  
**NOTE:** 1) Before changing the value, check the current setting, in case you need to recover the previous setting. (Default for SP6-023-1 – "197," for SP6-023-2 – "200")  
2) Changing the value by +1 decreases the registration motor's on-time and feeds the paper 0.3 mm less.
4. Leave the SP mode, then check the paper feed performance. If the problem still occurs, repeat the above steps.

## 6.10 PRINTING SECTION

### 6.10.1 PRESSURE CYLINDER

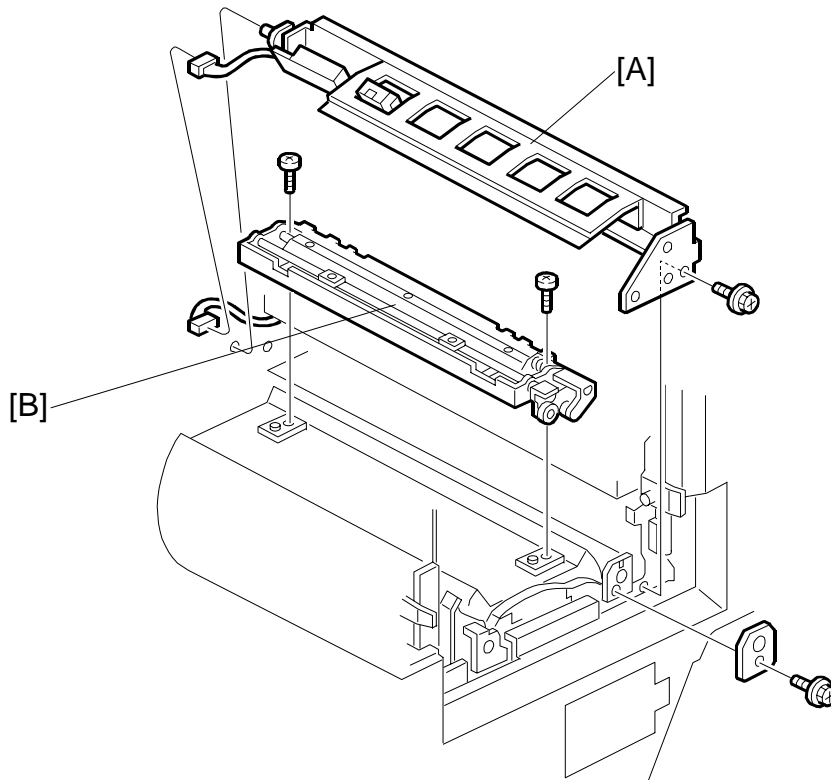

C235R022.WMF

**NOTE:** Take care when removing and replacing the pressure cylinder, because the pressure cylinder is made of soft rubber. Also, the encoder on the rear of the cylinder is easily damaged

#### ***Removal Procedure***

1. Remove the drum.
2. Remove the bracket [A] (1 screw, 1 connector).
3. Remove the left exterior cover (5 screws).
4. Remove the paper delivery unit and air knife fan unit. (See section 6.12.1, Paper Delivery Unit and Air Knife Fan Unit.)
5. Remove the exit pawl. (See section 6.12.4, Paper Exit Pawl Removal.)
6. Remove the paper clammer [B] (2 screws).



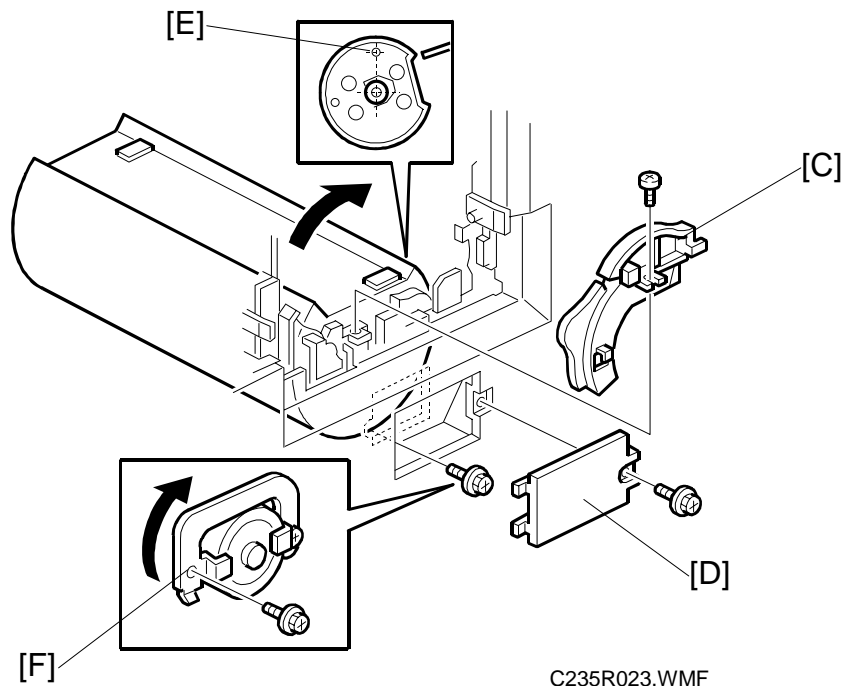

7. Remove the white cam [C] (1 screw).
8. Remove cover [D] from the inner cover (1 screw).
9. Turn the cylinder clockwise 80 degrees, so that the positioning hole [E] in the side of the cylinder is at the top. (The flat part of the cylinder faces towards the upper right, as shown.)
10. Remove the screw and flip over the stopper [F].

11. Put the right hand into the side trapezoid hole (for removing lower wrapping jams), and support the bottom of the cylinder.
12. Pull it a little toward you (to disengage the joint behind the cylinder). Then, push up to the drum position.

**CAUTION:** There is the encoder plate at the rear of the cylinder. Be careful not to damage it when removing the cylinder.

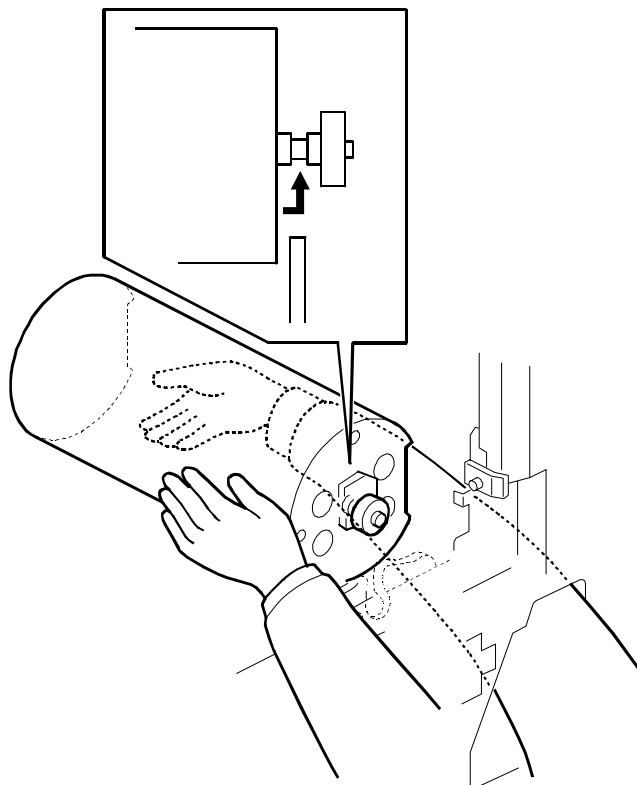

C235R103.WMF

13. Pull the cylinder toward you, and rest it on the flat area of the inner cover [G].
14. With the left hand, hold the bearing tightly, putting fingers into the holes as shown.
15. Support the rear of the pressure cylinder with the right hand. Then, bring out the cylinder using both hands.

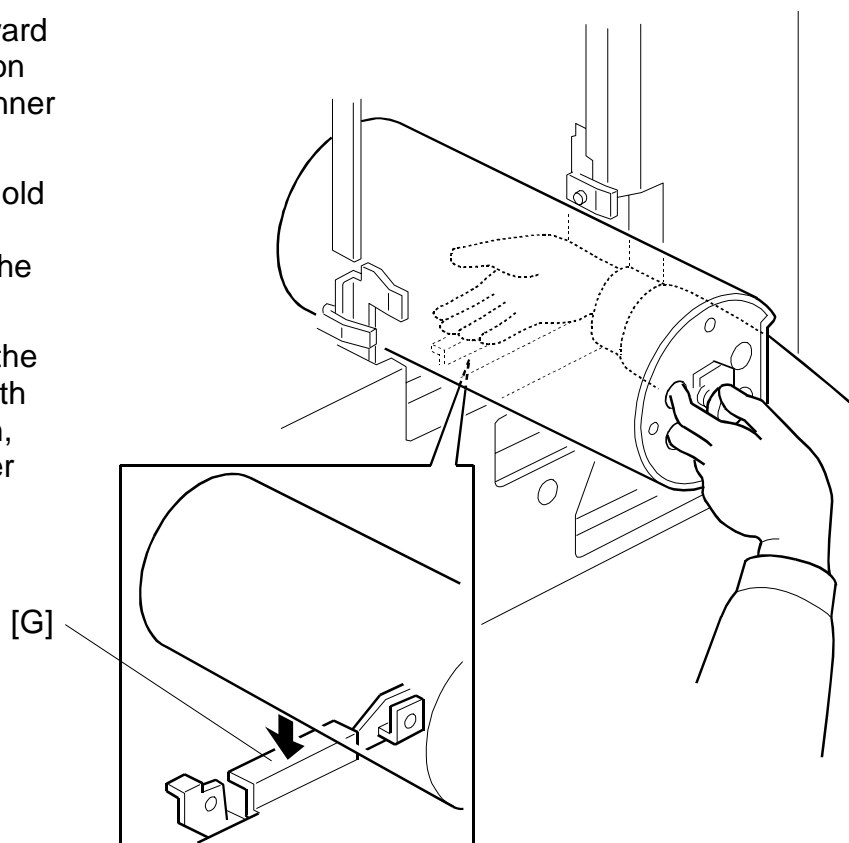

C235R104.WMF

**Reinstallation procedure**

**CAUTION:** Take care not to turn the drive accidentally after removing the cylinder. When the drive is in position, the cutout (for engagement) in the drive conductor (white disk) [A] is positioned horizontally but leans to the upper right just slightly.

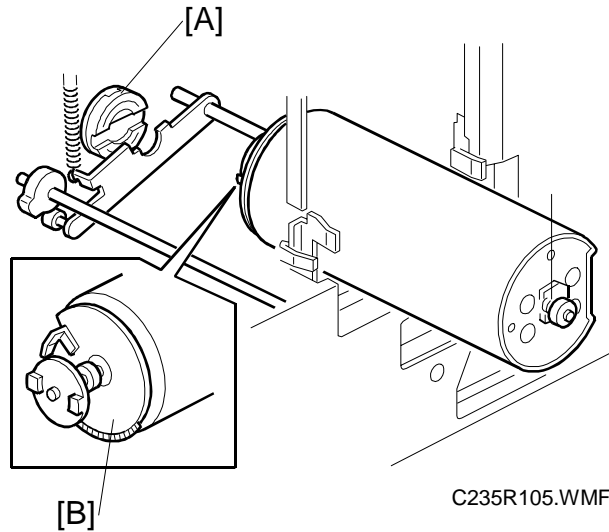

1. Hold the pressure cylinder so that the round hole [C] is uppermost. Rest the pressure cylinder on the flat area of the inner cover [D].

**CAUTION:** There is an encoder plate [B] at the rear of the cylinder. Be careful not to damage it when installing the cylinder.

2. With the left hand, hold the bearing tightly, putting fingers into the holes as shown.
3. Support the rear of the pressure cylinder with the right hand. Put the right hand into the side trapezoid hole (for removing lower wrapping jams), and support the bottom of the cylinder.

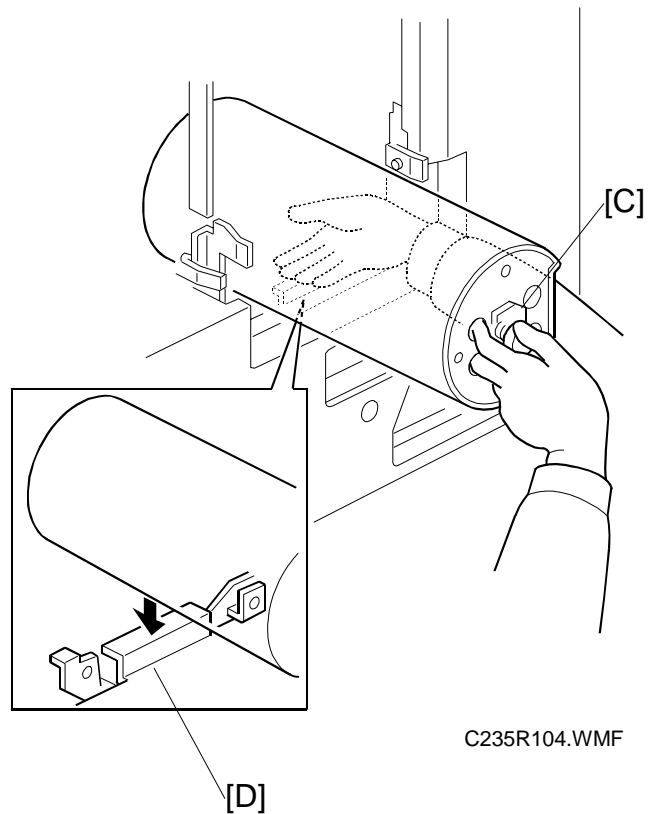

Replacement Adjustment

4. Then, put the pressure cylinder into the hole where the drum was using both hands.
5. Install the pressure cylinder, while positioning the thinnest part of the shaft of the bearing [E] with the clamber cam (the black cam) as shown to the right. Position the bearing [E] on the bearing holder.

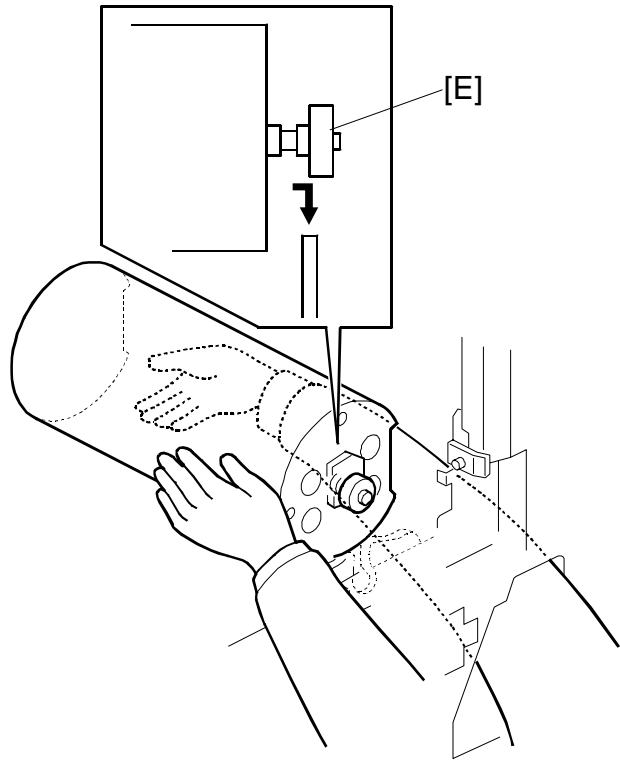

C235R638.WMF

6. While the round hole [F] is uppermost, push the pressure cylinder towards the non-operation side (to engage the joint behind the cylinder).

**NOTE:** 1) If it cannot enter, push while turning the pressure cylinder a little. Check if the joint is engaged properly by turning the cylinder slightly.  
 2) Set the bearing stopper [G] as shown.

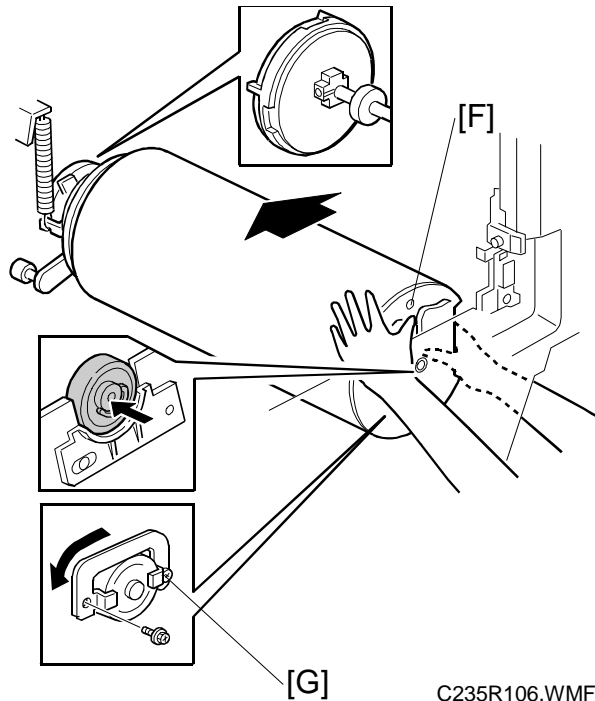

C235R106.WMF

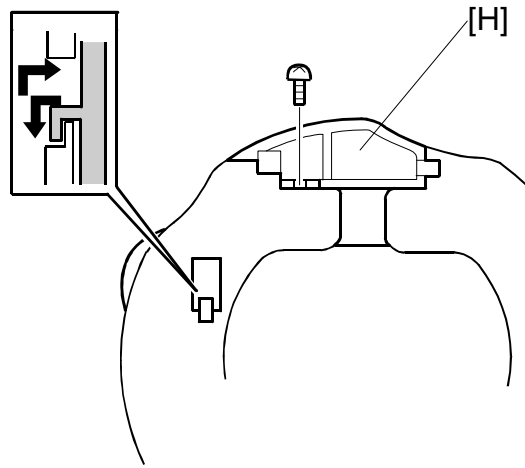

C235R030.WMF

7. Install the white cam [H] as shown.
8. Reassemble the machine.

### 6.10.2 FEED START SENSOR AND FEED ENCODER

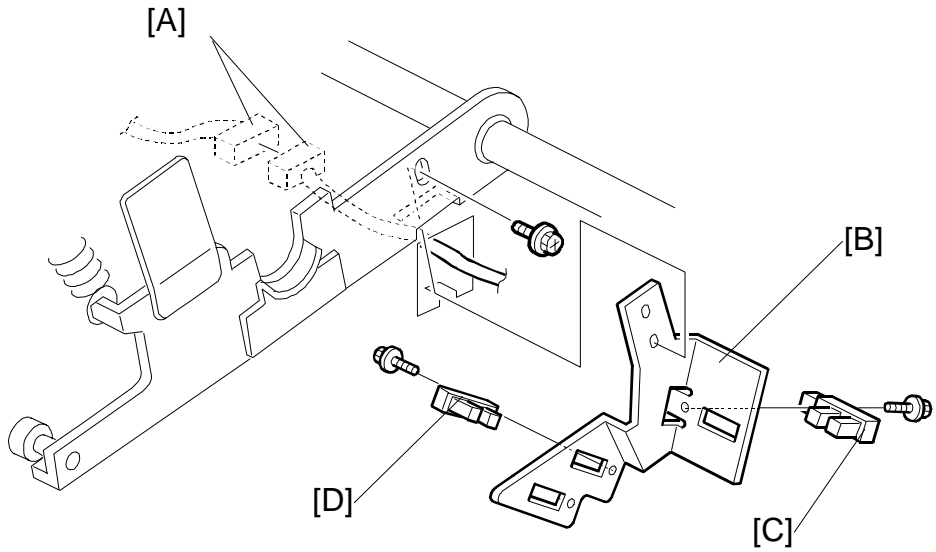

C235R024.WMF

1. First, remove the pressure cylinder. (See section 6.10.1, Pressure Cylinder.)
2. From the rear of the machine, swing out the MPU. (See 6.4 MPU and PSU Opening Procedures.)
3. Disconnect the connectors [A] from the rear of the machine.
4. Remove bracket [B].
5. Remove the feed encoder [C] and feed start sensor [D].

**CAUTION:** Make sure if there is a gap [E] between the sensor bracket and the printing pressure release arm [F]. There must be no gap or less than 0.2 mm.

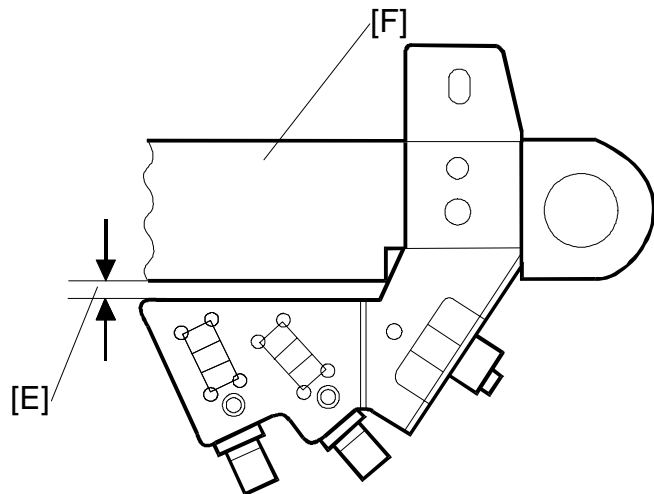

C235R702.WMF

### 6.10.3 PRINTING PRESSURE ADJUSTMENT

**PURPOSE:** To improve the print results.

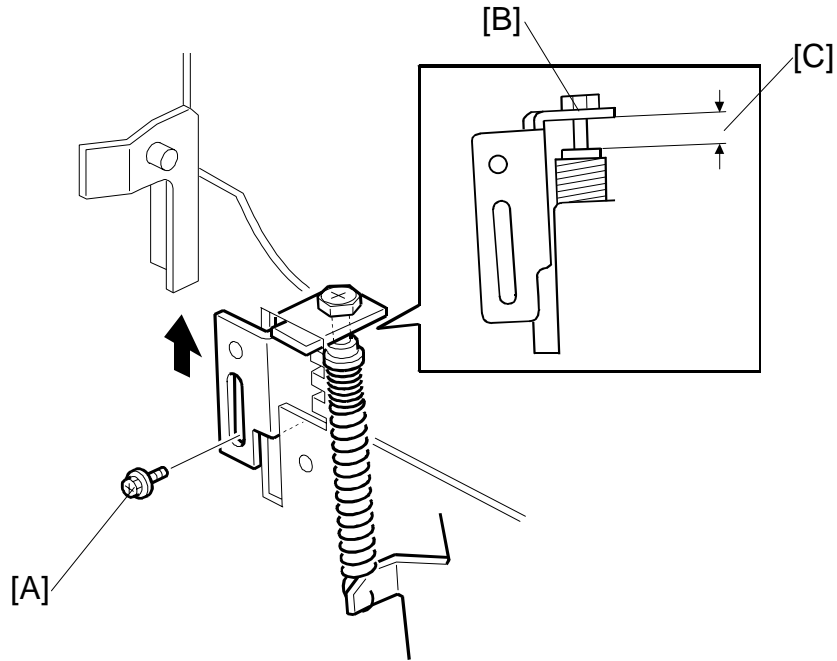

C235R109.WMF

1. Move the printing pressure bracket to its highest position, then tighten the screw [A].
2. Adjust the clearance [C] to be  $6.2 \pm 0.4$  mm by turning the bolt [B].

Replacement  
Adjustment

### 6.10.4 PRINTING PRESSURE RELEASE ARM GAP ADJUSTMENT

**PURPOSE:** To ensure that printing pressure release lever is disengaged when the printing pressure release solenoid is energized.

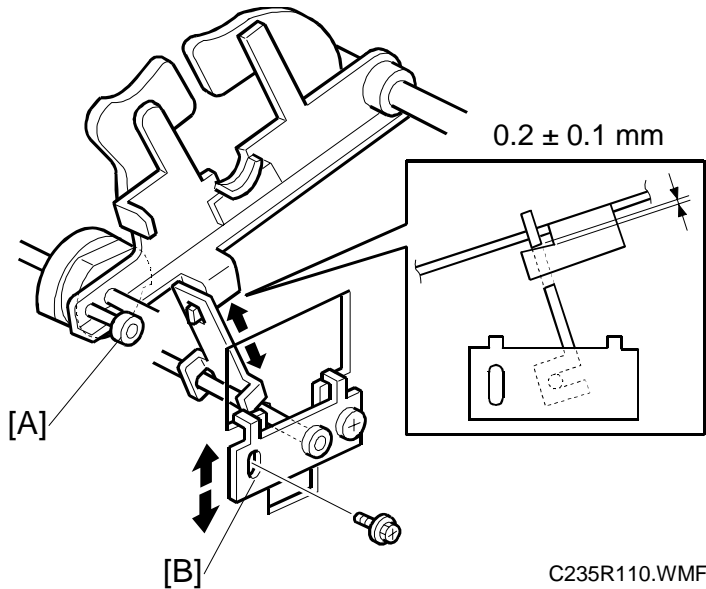

1. Rotate the printing pressure cams so that the arm moves to the lower most position.  
**NOTE:** Use the main drive rotation knob. When the top of the cam meets the bearing [A] during turning the knob, the arm is at to the lower most position.
2. Adjust the clearance between the hook and the printing pressure release arm by moving the bracket [B] up and down. The clearance must be  $0.2 \pm 0.1$  mm.
3. Do the same at the non-operation side.



## 6.11 MAIN DRIVE AND IMAGE UP/DOWN SHIFTING DRIVE SECTION

### 6.11.1 MAIN MOTOR AND TORQUE LIMITER

#### *Removal procedure*

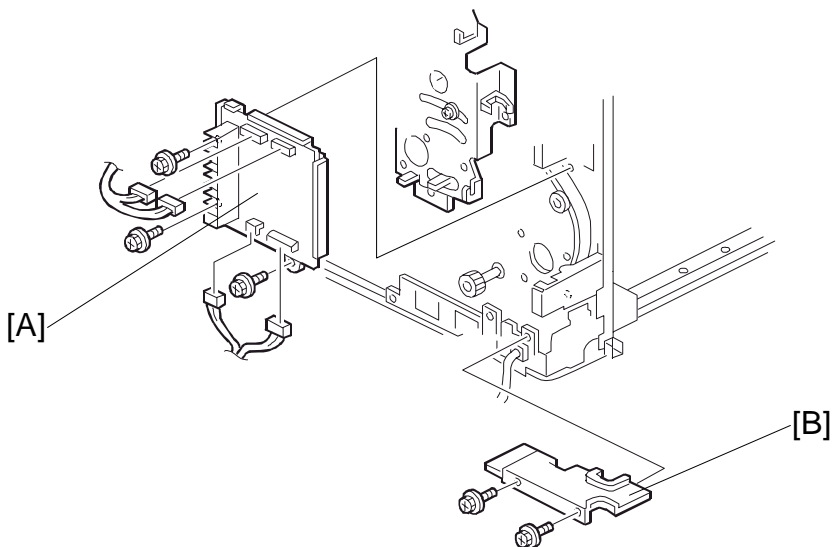

C235R703.WMF

#### **- From the rear -**

1. Turn off the main switch and remove the rear cover (6 screws, 1 ground wire).
2. Swing out the PSU. (See 6.4 MPU and PSU Opening Procedures.)
3. Remove the main motor control board [A] (3 screws, 4 connectors).
4. Remove the wire protection cover [B] (2 screws).

**Replacement  
Adjustment**

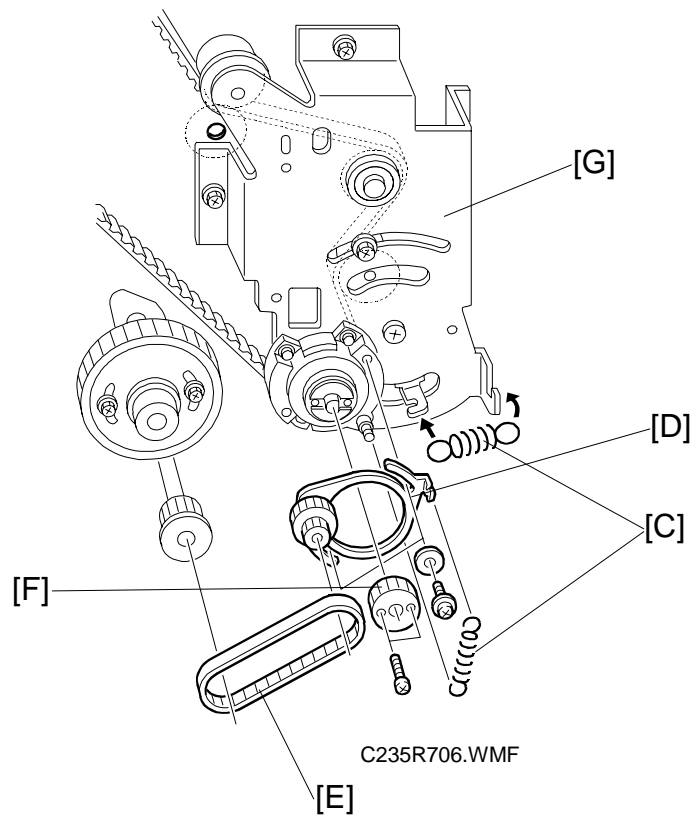

5. Remove the 2 springs [C].
6. Remove the pulley bracket [D] (2 screws).
7. Remove the timing belt [E].
8. Remove the gear [F].
9. Remove the bracket [G] (5 screws, 2 cord clamps).

**CAUTION:** The screw is under the main wire harness. Take care not to damage the wire harness when removing it.

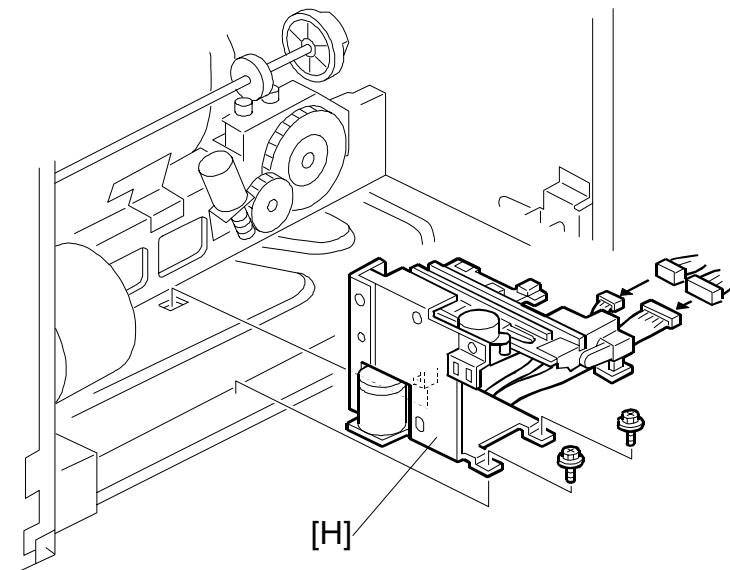

C235R622.WMF

**- From the paper exit side -**

10. Remove the paper delivery cover (4 screws).
11. Remove the job separator unit [H] (2 screws).

Replacement  
Adjustment

– Again, from the rear –

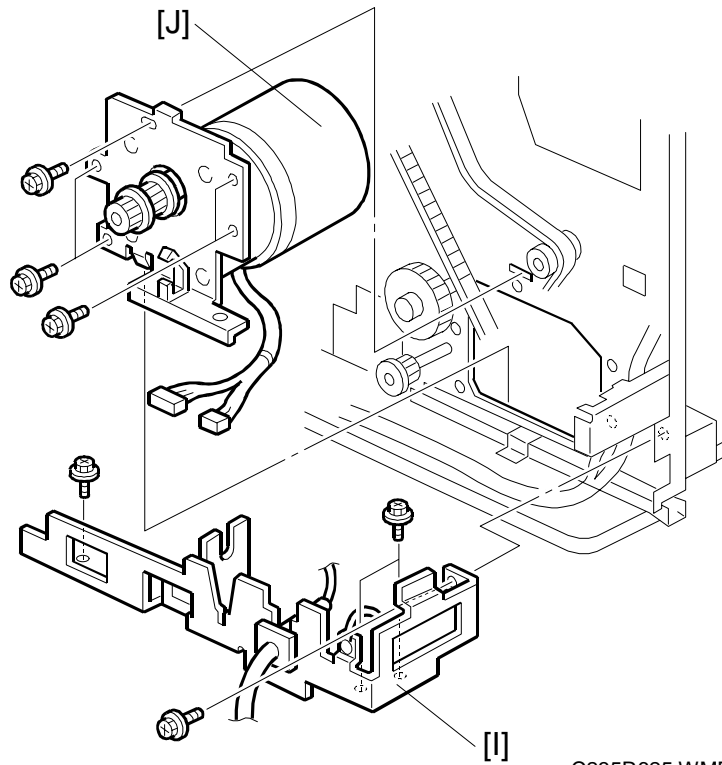

C235R625.WMF

- 12. Remove the power cord bracket [I] (4 screws).
- 13. Remove the main motor [J] (5 screws).

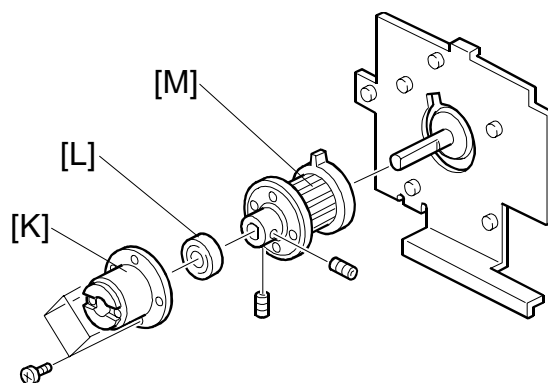

C235R707.WMF

- 14. Remove the bracket [K].
- 15. Remove the bearing [L].
- 16. Remove the torque limiter [M].

**Reinstallation procedure**

**CAUTION:** After you replace the main motor, you must adjust the exit pawl drive timing. (See section 6.12.6, Paper Exit Pawl Drive Timing Adjustment.)

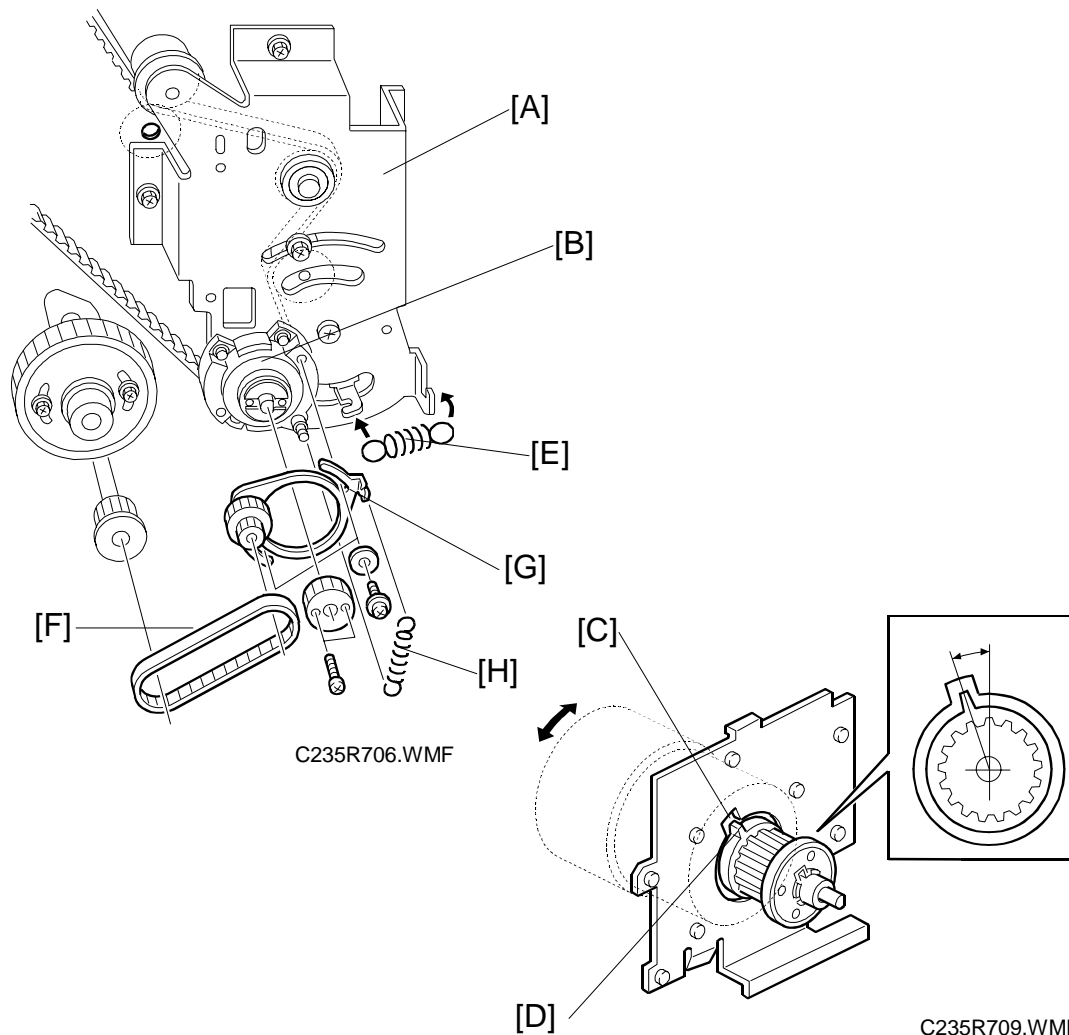

1. Install the torque limiter.
2. Install the bracket [A].
3. Install the bearing [B].
4. Align the cutout in the bracket [C] with the pawl on the torque limiter [D] as shown.
5. Attach the spring [E].

**CAUTION:** If the cutout and pawl are in line, the main motor drive is OK. If they are not, remove the spring [E], then make sure that the cutout and pawl are in line again.

6. Install the timing belt [F] and pulley bracket [G].
7. Install the spring [H].

Replacement  
Adjustment

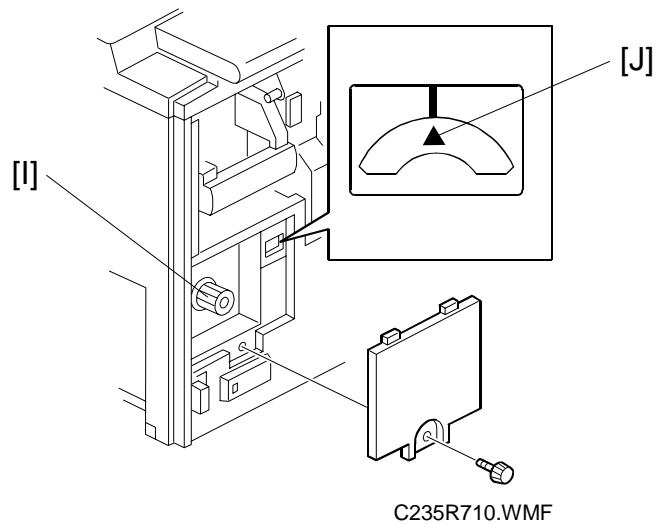

**CAUTION:** When you install the pulley bracket [G], adjust the knob [I] until the line and arrow on the indicator disk are in line [J].

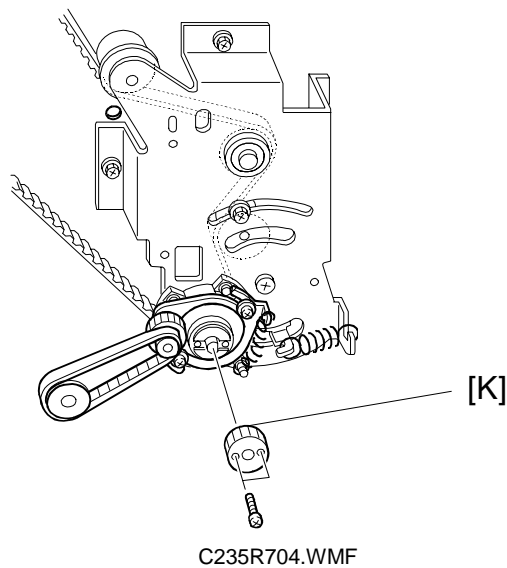

8. Install the gear [K] (2 screws).
9. Install the wire protection cover.
10. Install the main motor control board.
11. Install the rear cover.

### 6.11.2 MAIN DRIVE MECHANISM (MAIN DRIVE TIMING BELT)

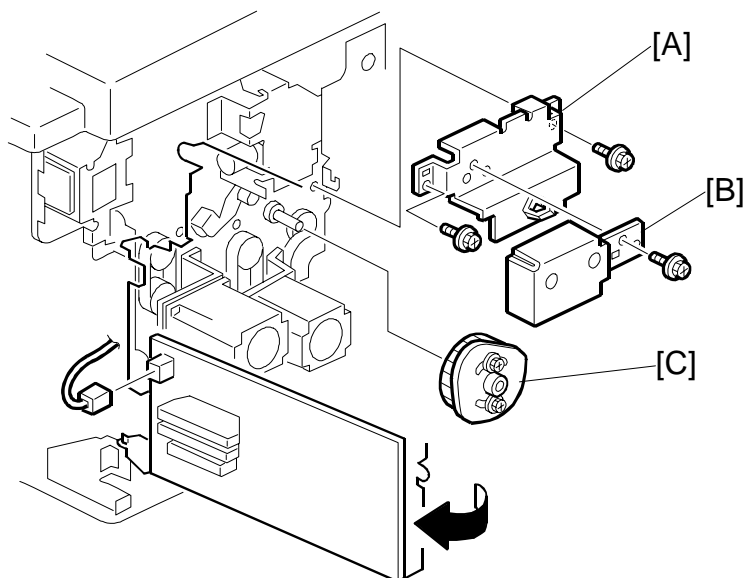

C235R601.WMF

#### ***Disassembly Procedure***

1. Turn off the main switch and disconnect the power plug.
2. Remove the drum.
3. Remove the rear exterior cover (6 screws, 1 ground wire).
4. Swing out the MPU and PSU. (See 6.4 MPU and PSU Opening Procedures.)
5. Remove the pulley cover [B] and the bracket [A].
6. Remove the registration roller lifting cam [C].

**Replacement  
Adjustment**

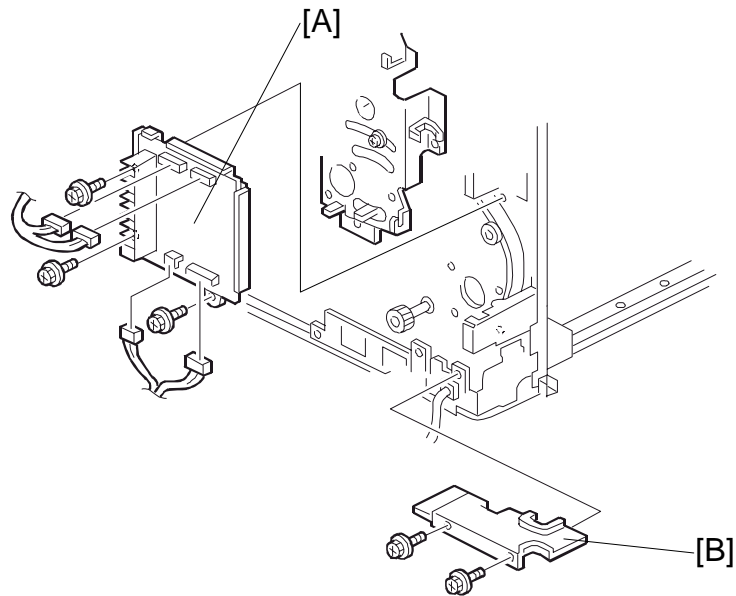

C235R703.WMF

**- From the rear -**

7. Remove the main motor control board [A] (3 screws, 4 connectors).
8. Remove the wire protection cover [B] (2 screws).



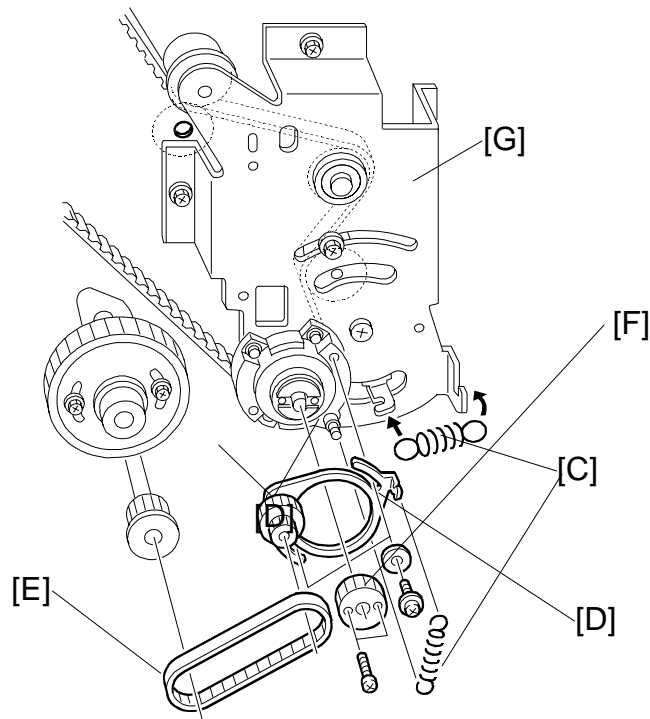

C235R706.WMF

9. Remove the 2 springs [C].
10. Remove the pulley bracket [D] (2 screws).
11. Remove the timing belt [E].
12. Remove the gear [F].
13. Remove the bracket [G] (5 screws, 2 cord clamps).  
**CAUTION:** The screw is under the main wire harness. Take care not to damage the wire harness when removing it.

Replacement  
Adjustment

14. Remove the image shifting unit [H] (3 screws, 3 connectors).

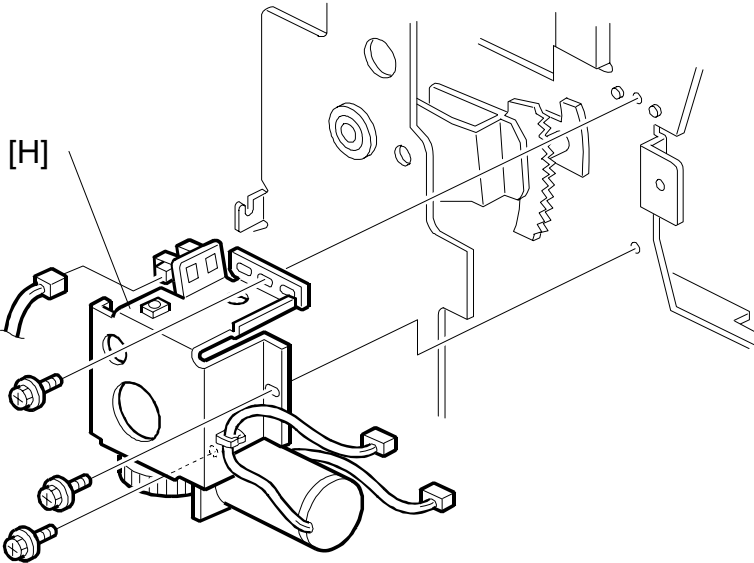

C235R119.WMF

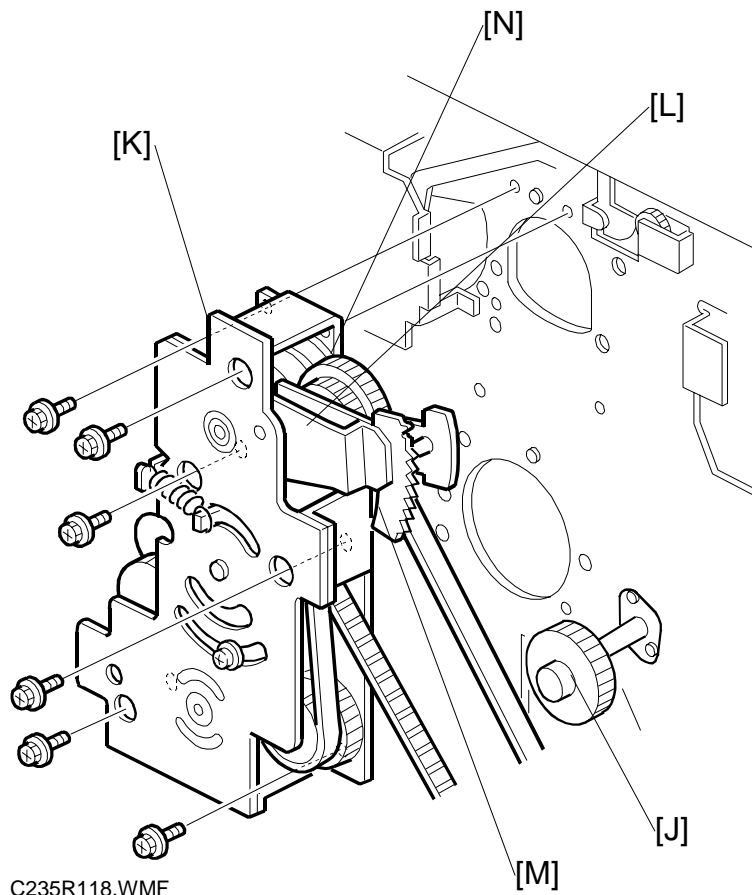

15. Remove the printing pressure cam drive gear [J] (2 screws).
16. Remove the supporter for PSU and MPU (4 screws).
17. Remove the drive unit [K] (6 screws, 1 cord clamp).
18. Disassemble the drive unit to remove the upper cover (2 E-rings, 2 bearings, 1 spring, 7 screws).
19. Remove the image shifting arm [L].
20. Remove the sector gear [M].
21. Remove the image shifting gear [N] and the drive gear.
22. Replace the main drive timing belt.

### ***Reassembly Procedure***

The following items must be checked or set while reinstalling the main drive section:

- Drum home position
- Image shifting arm home position
- Pressure cylinder drive reinstalling position
- Scissors gear reinstalling position
- Printing pressure cam drive gear reinstalling position
- Registration roller lifting cam reinstalling position
- Paper exit pawl drive cam reinstalling position
- Pressure cylinder rotation knob position

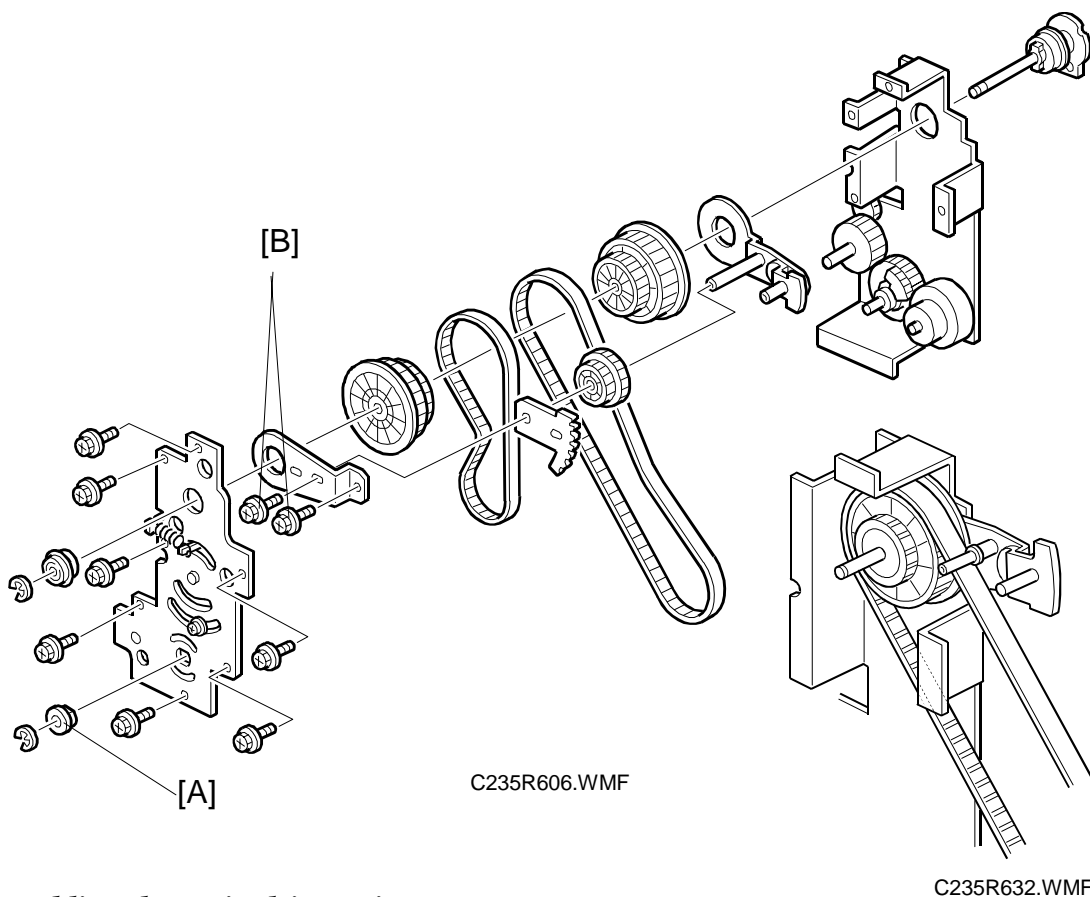

### ***Assembling the main drive unit***

1. Reassemble the main drive unit (1 spring and 7 screws).

**NOTE:** In this step, the bushing [A] (and the E-ring) must not be installed. Install these in step 9. In addition, do not install the two screws [B] securing the image shift arm. Install them in the next step.

2. Tighten the two screws [A] to assemble the image shift arm and image shift gear.

**NOTE:** Install the two screws temporarily, since you must retighten them in step 5.

3. Make sure that the plate on the rear of the image shift arm is firmly set on the bearing sleeve [B] as shown.

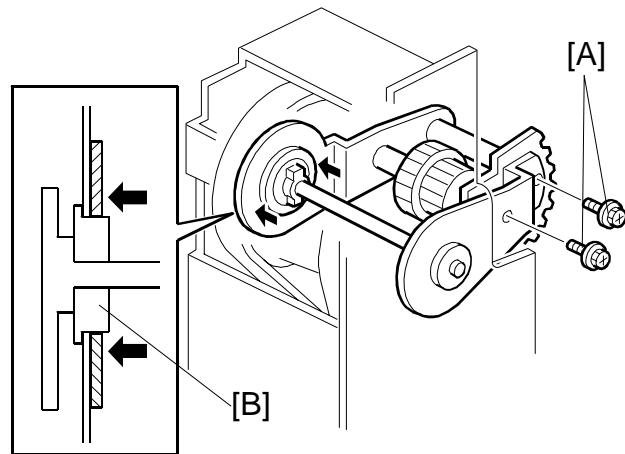

C235R604.WMF

**CAUTION:** Once the two screws [A] are loosened, the rear plate of the image shift arm easily slips off the bearing sleeve. Make sure that the rear plate is on the bearing sleeve properly also before installing the main drive unit on the machine rear frame in step 13.

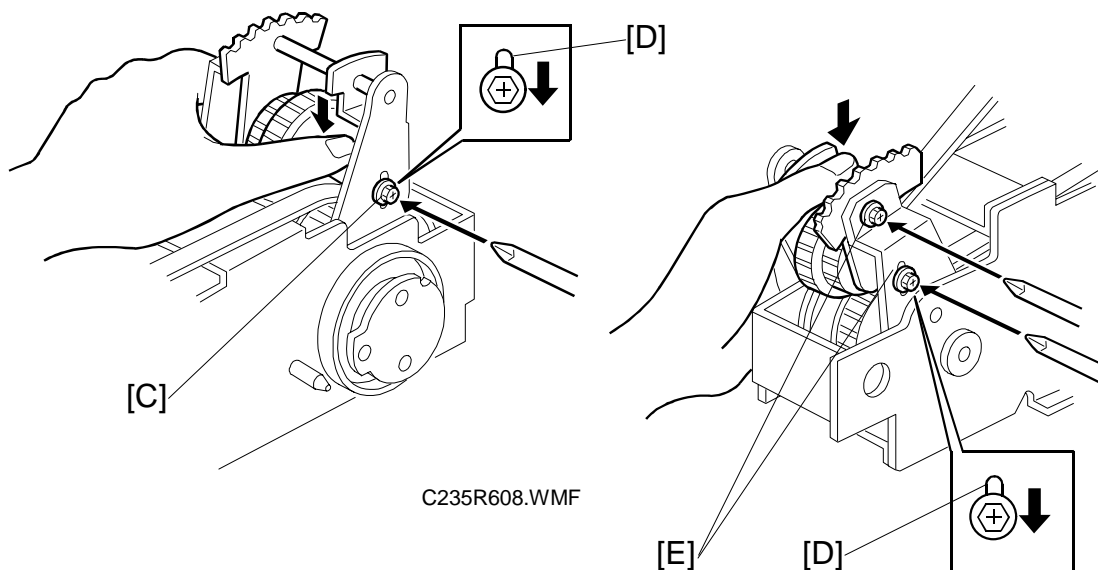

C235R608.WMF

4. Strongly push the shaft of the image shift gear against the other gears, and firmly tighten the screw [C].
5. Similarly, tighten the two screws [E] while pushing the arm shaft against the other gears strongly.

**NOTE:** Step 4 and 5 are to remove play between the image shift gear and other gears. There must be no gear play between these gears. The screws are set through long holes [D]. Make sure that the screws reach the end of the long hole when tightening them.

6. Make sure that the image shift gear smoothly moves along the drum drive gear.

C235R631.WMF

Replacement  
Adjustment

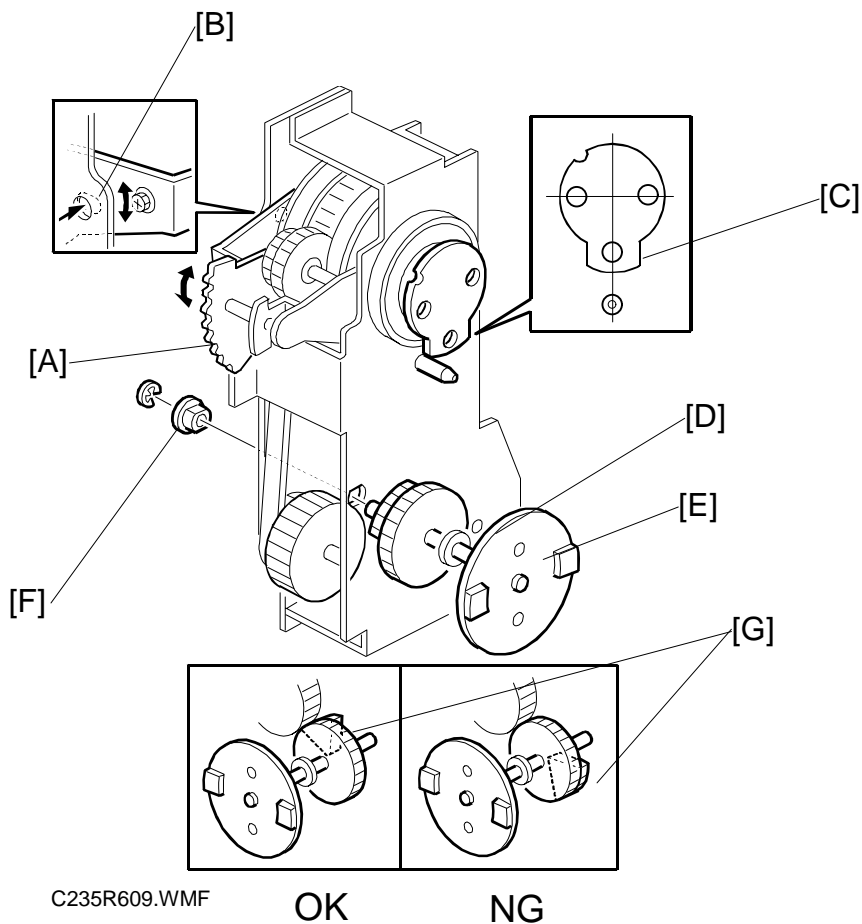

***Setting the drum drive disk, image shifting arm, pressure cylinder drive disk, and scissors gear in their home positions***

7. To set the drum drive disk in the home position, align the elongated hole [C] in the drum drive disk straight downwards by turning the disk.
8. Set the image shift arm [A] in the home position. Align the hole in the upper plate [B] with the elongated hole in the image shift arm.
9. Align the hole in the pressure cylinder drive disk [E] with the hole in the side plate of the drive unit [D], then install the bushing [F] (one E-ring).

**NOTE:** Before installing the bushing [F], make sure that the scissors gear [G] also meshes with the next gear. If the scissors gear is set incorrectly by 180 degrees, the scissors gear will not mesh with that gear. (See OK and NG in the diagram above.)

***Installing the main drive unit on the machine rear frame*****- From the paper exit side -**

10. Remove the paper delivery unit and air knife unit. (See 6.12.1 Paper Delivery Unit and Air Knife Fan Unit.)
11. Remove the job separator unit [A] (2 screws).
12. Remove the paper exit pawl. (See 6.12.5 Paper Exit Pawl Removal.)

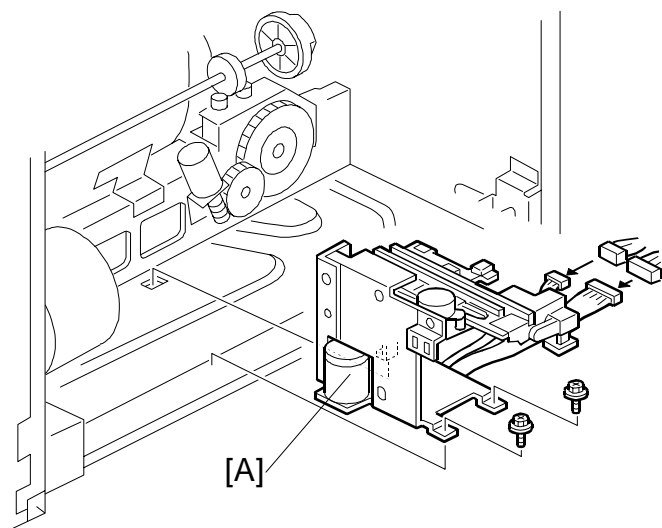

C235R622.WMF

13. While aligning and holding the pressure cylinder horizontally as shown, set the main drive unit so that the convex points of the pressure cylinder's drive disk [C] meet the concave points of the pressure cylinder drive transmission disk [B] (made of white plastic).

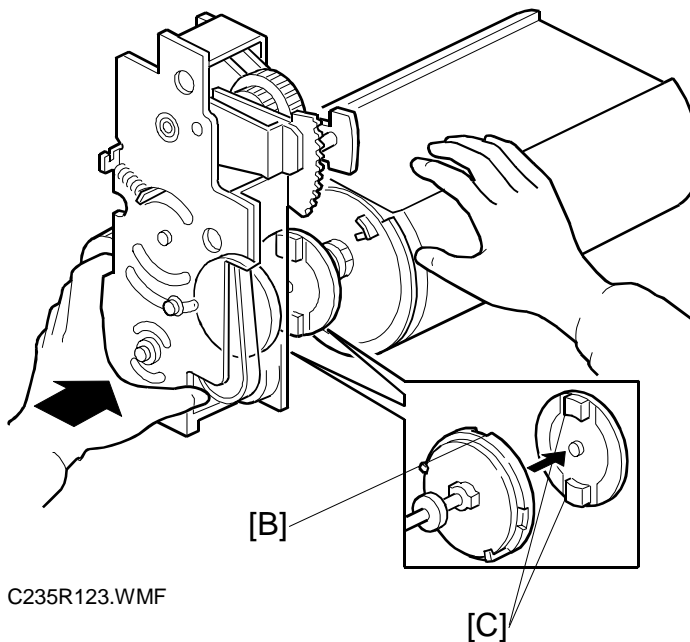

C235R123.WMF

**NOTE:** Hold the drum drive disk, image shifting arm, pressure cylinder drive disk, and scissors gear in their home positions as explained in step 7, 8, and 9. In addition, make sure that the rear plate is on the bearing sleeve properly as explained in step 3.

**Replacement  
Adjustment**

14. Secure the main drive unit on the machine rear frame (6 screws).

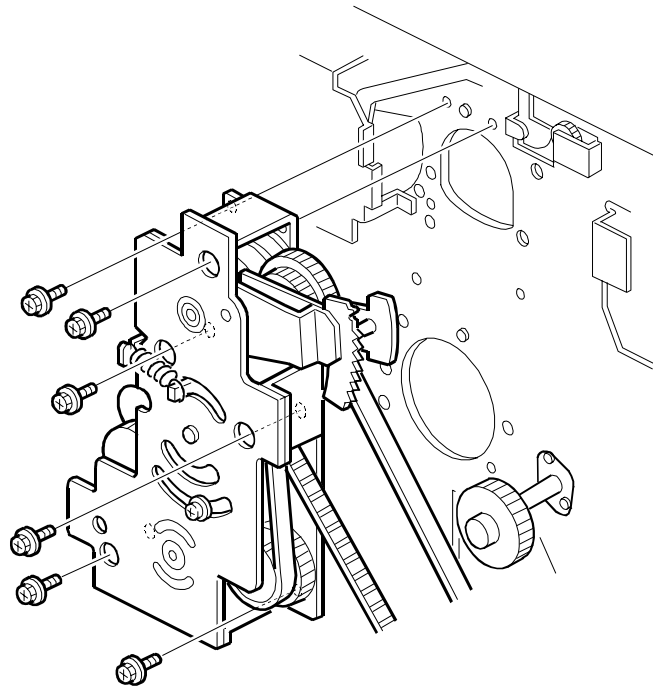

C235R118.WMF

15. Make sure that the image shift arm [B] is in the home position. Align the hole in the upper plate [A] with the elongated hole in the image shift arm (as explained in step 8).

16. Push the image up/down shift drive unit [C] against the image shift arm sector gear, and secure the unit (3 screws, 3 connectors).

**NOTE:** 1) Ensure that the unit is set without any play.  
 2) Do not push on the unit too strongly. Ensure that the image shift arm moves smoothly after securing the unit. If it does not, SC05-10 will be displayed at power up.

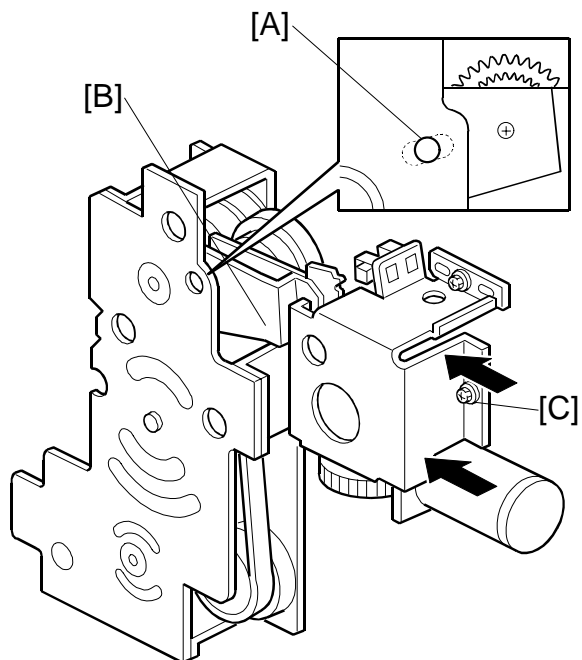

C235R124.WMF

17. Install the main drive timing belt on the main motor shaft, and reassemble the parts of the main motor area. (Refer to steps 7 through 13 of the Disassembly procedure.)



***Fine adjustment using the special tools***

**NOTE:** The tools are available as a service part. The part number is #C229 9000 (three parts as a set).

18. Make sure that the drum drive disk is in the home position by setting the drum drive securing tool [A].

**NOTE:** If the special tool is not available, align the elongated hole in the drum drive disk [B] with the shaft [C] below it, as shown.

19. Install the drum unit in the machine.  
20. Close the front cover, connect the power plug, then turn on the main switch. The up/down image shifting mechanism will initialize.

**NOTE:** This procedure is needed to return the image shift arm to its home position. If the image shift arm is not returned to home position exactly in this step, correct positioning for each main drive part will not be obtained.

21. Turn off the main switch, and disconnect the power plug.  
22. Remove the drum and again set the drum drive-securing tool [A].  
23. From the rear, loosen the two screws [D] to allow the pressure cylinder drive gear to turn freely.

**NOTE:** Do not remove the screws.

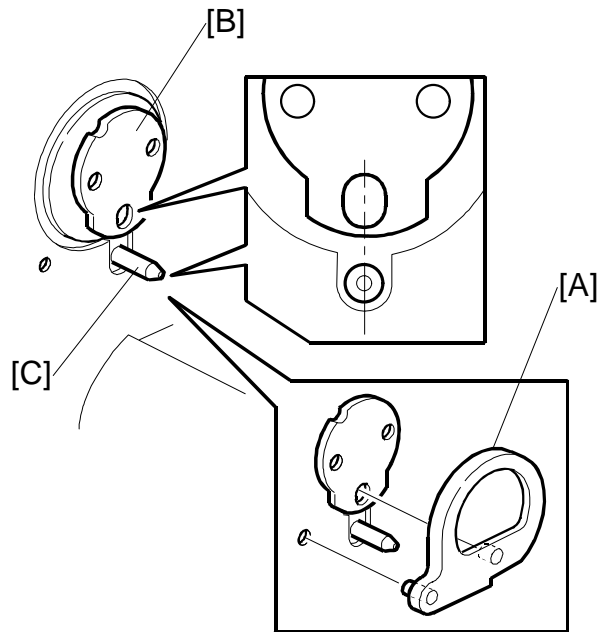

C235R181.WMF

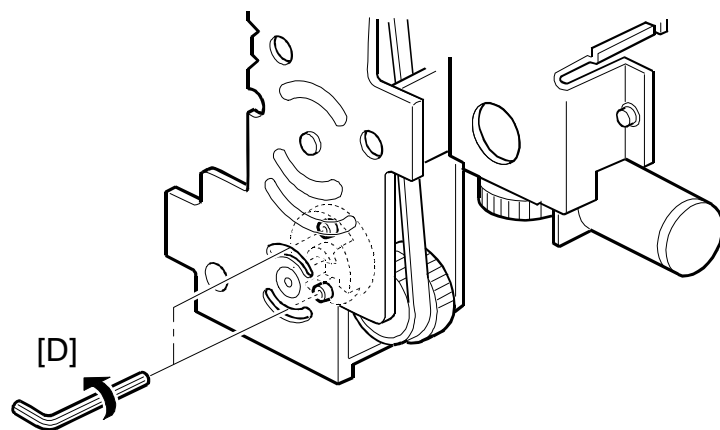

C235R125.WMF

Replacement  
Adjustment

24. Remove the printing pressure cam shift unit [A].
25. Remove the front exterior and inner covers (4 screws each).

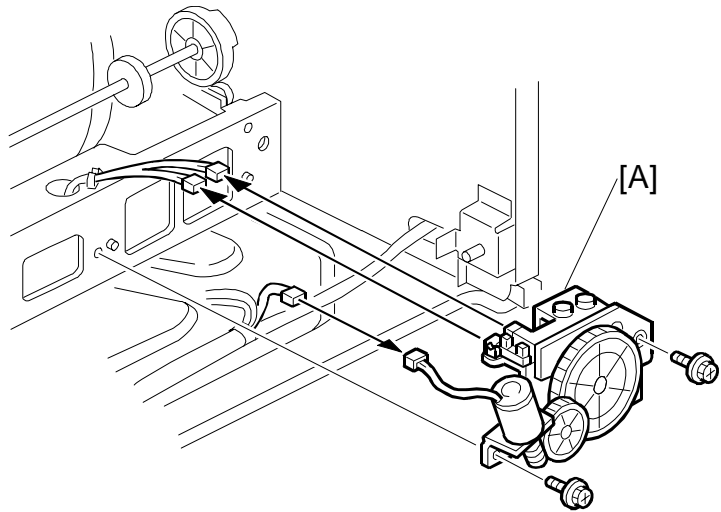

C235R607.WMF

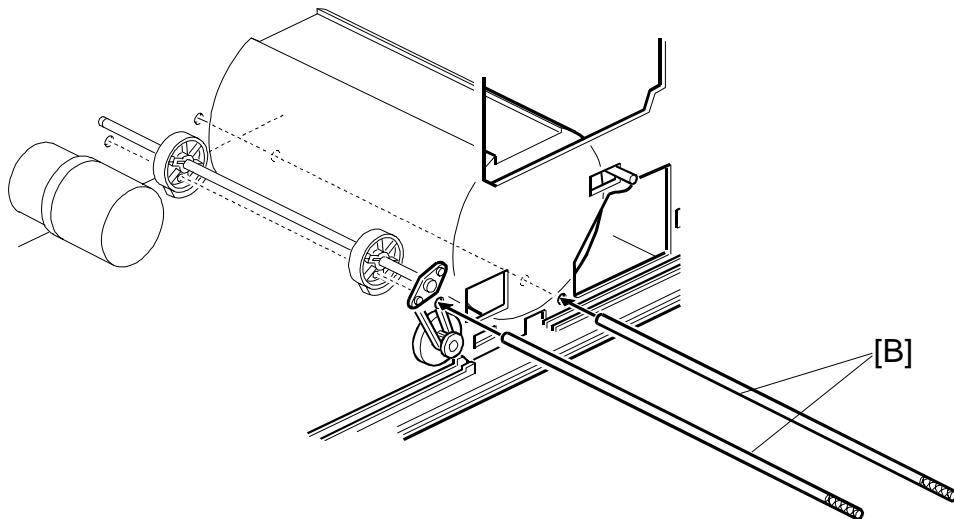

C235R126.WMF

26. From the operation side of the machine, insert the two positioning shafts [B] (special tools) to secure the pressure cylinder and printing pressure cams in their home positions.
  - Pass one shaft through the pressure cylinder as shown.
  - Pass the other shaft through the two printing pressure cams as shown.

27. Remove only the drum drive-securing tool (leave the two positioning shafts). Then turn the main motor [B] clockwise by hand until the drum drive disk [C] has turned about 10 degrees, as shown.

**NOTE:** Although the motor will not turn smoothly since the drive is secured with the special tools, this is normal.

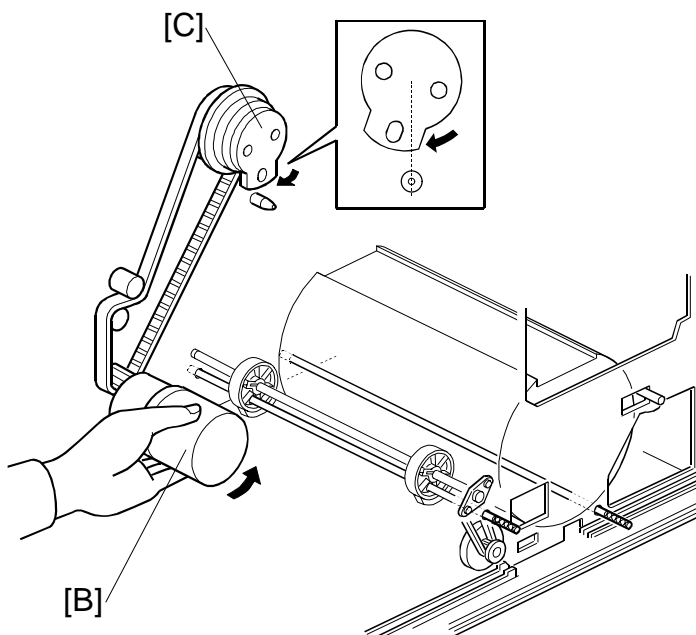

C235R635.WMF

28. Turn the main motor [A] counterclockwise, and set the drum drive disk [B] in the home position. (If the disk is turned too much at this point, reset from step 26.)

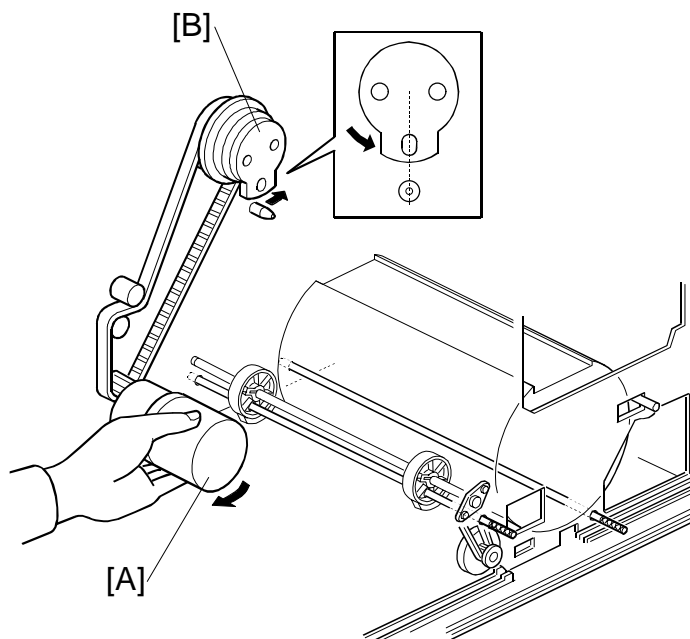

C235R636.WMF

**CAUTION:** These steps are needed to put gear play in the direction opposite to the printing direction. Make sure to turn the main motor by hand in the above order (steps 27 and 28). If the motor is turned in wrong order, the main drive will turn slightly when the two shafts (special tools) are removed. If you turned it in the wrong order, return to step 27 then do step 28.

Replacement  
Adjustment

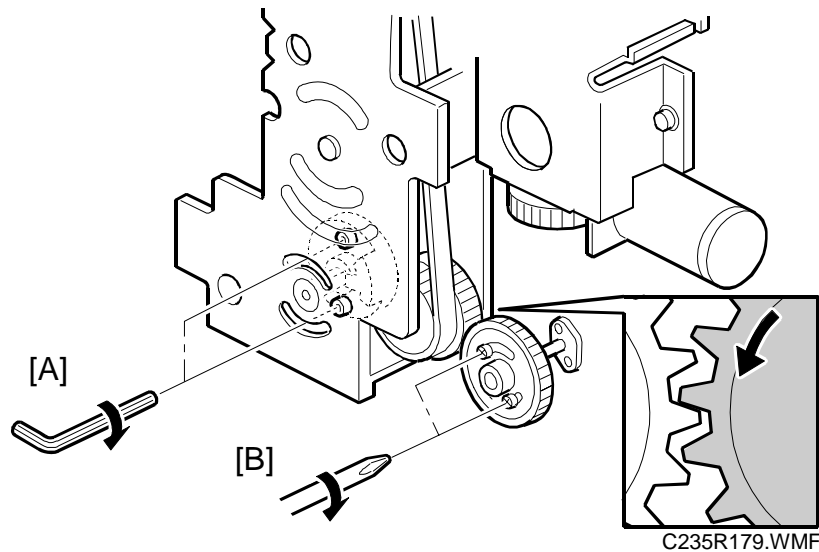

29. Set the drum drive-securing tool once again. (See step 18.)

**CAUTION:** Do not turn the drum drive disk by force while setting the tool. If you turned the disk, return to step 27 then do step 28.

30. Secure the pressure cylinder drive gear [A] (2 screws).

**CAUTION:** Don't turn the gear by force while securing it.

31. Install the printing pressure cam drive gear and firmly tighten the 2 screws [B].

**NOTE:** 1) To remove gear play, secure the cam drive gear while turning it counterclockwise (as viewed from the rear).  
2) Secure the cam drive gear by tightening the two screws in the middle of the curved oval holes. This allows for the maximum adjustable range for later repositioning of the gear.

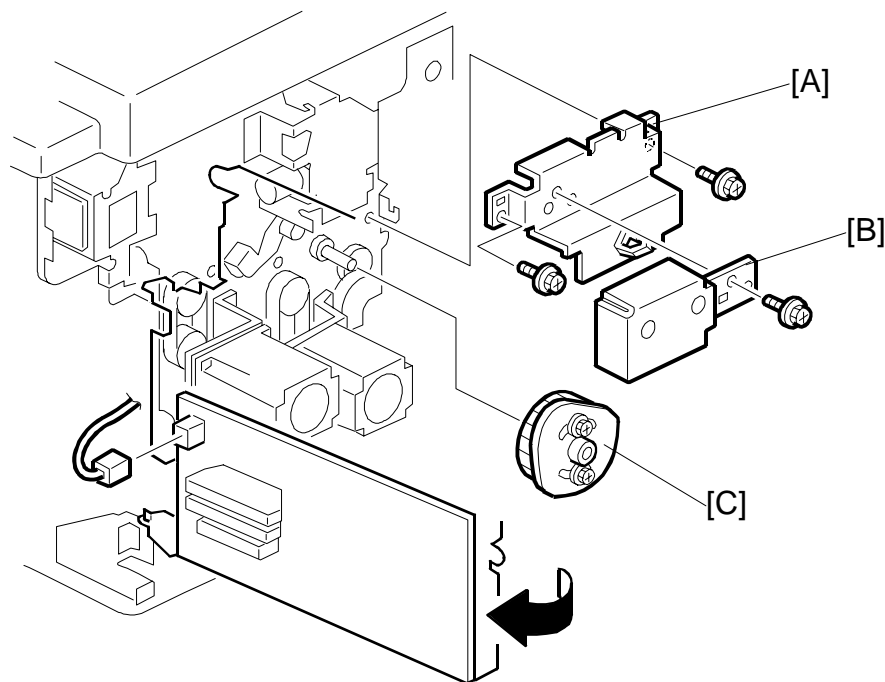

C235R601.WMF

### *Finishing*

32. Install the registration roller lifting cam [C]. (See 6.9.9 Registration Roller Lifting Cam Position Adjustment for the correct position of the cam.)
33. Install the pulley cover [B] and bracket [A].
34. Install the exit pawl, and adjust the paper exit pawl drive timing. (See 6.12.7 Paper Exit Pawl Drive Timing Adjustment.)
35. Adjust the pressure cylinder rotation knob. (See 6.11.3 Pressure Cylinder Rotation Knob Adjustment.)
36. Remove all special tools (the drum drive-securing tool and two positioning shafts).
37. Adjust the gap between the exit pawl and the drum. Also adjust the gap between the paper scraper and the pressure cylinder. (See 6.12.6 Gap Adjustment between Paper Pick-off Plate and Pressure Cylinder and 6.12.8 Gap Adjustment between Exit Pawl and Drum.)

Replacement  
Adjustment

***Copy Image Check Procedure after Main Drive and Image Up/Down Shifting Drive Section Re-assembly***

When the main drive mechanism is disassembled and assembled, the image position on copies may fluctuate due to play in the drive components.

Whenever you disassemble the main drive mechanism, you must check the following items for the copy quality:

***When the image position on copies is not constant***

- Check the pressure cylinder position.  
Use the positioning shaft (a special tool) to check if the position of the pressure cylinder is correct. See steps 26 through 30 in "Reassembly Procedure" of 6.11.2 Main Drive Mechanism (Main Drive Timing Belt).

***When the leading edge margin of copies (8 mm) is not constant***

- Check the position of the printing pressure cams.  
Use the positioning shaft (a special tool) to check if the cam position is correct. See steps 26 through 31 in "Reassembly Procedure" of 6.11.2 Main Drive Mechanism (Main Drive Timing Belt).
- Check if you followed steps 18 through 21 in "Reassembly Procedure" of 6.11.2 Main Drive Mechanism (Main Drive Timing Belt).

***Other procedures if copy image problems are still detected***

- Check the image up/down shift drive unit position.  
See 6.11.6 Image Up/Down Shift Drive Unit Position Adjustment. Also, see 6.11.5 Image Up/Down Shift Worm-gear Position Adjustment.
- Check the image shift gear play.  
See steps 2 through 6 in "Reassembly Procedure" of 6.11.2 Main Drive Mechanism (Main Drive Timing Belt).
- Check the scissors gear position.  
See step 9 in "Reassembly Procedure" of 6.11.2 Main Drive Mechanism (Main Drive Timing Belt). Also, see 6.11.4 Scissors Gear Position Adjustment.

### 6.11.3 PRESSURE CYLINDER ROTATION KNOB ADJUSTMENT

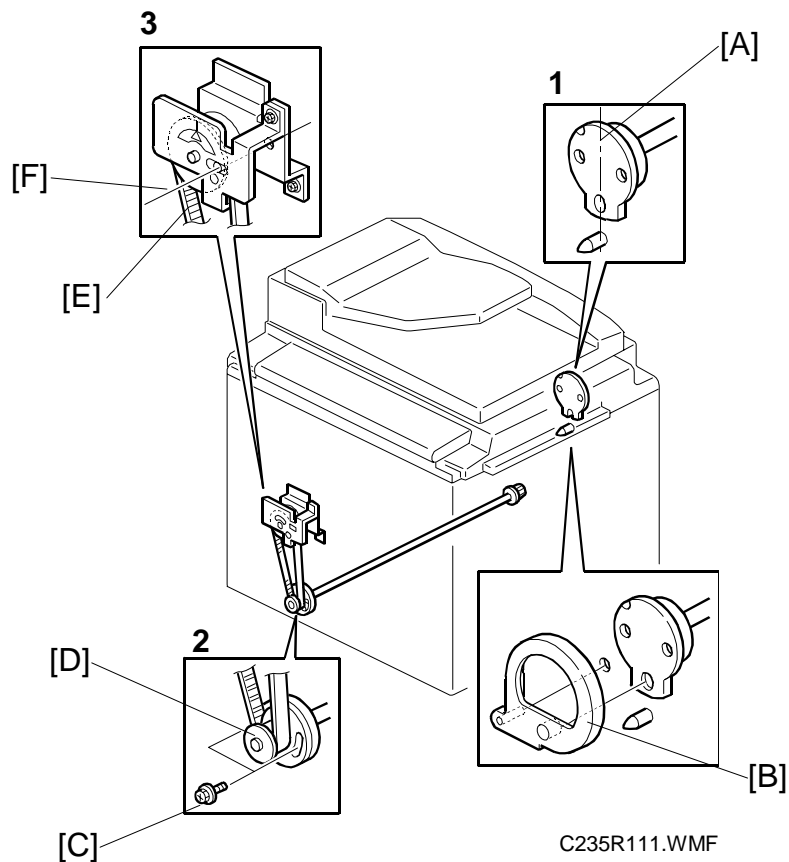

1. Set the drum drive securing tool [B] (a special tool) as shown to hold the drum drive at home position.  
**NOTE:** If the special tool is not available, align the long hole of the drum drive disk [A] exactly with the shaft below it.
2. Loosen two screws [C] so that the pulley [D] freely turns.
3. Turn the timing belt [E] by hand until the triangle mark on the indicator disk meets the center division. (When the indicator disk is in the correct position, the hole in the disk and the two holes in the bracket are in line, as shown [F].)
4. Retighten the two screws [C] to secure the pulley in position.

### 6.11.4 SCISSORS GEAR POSITION ADJUSTMENT

**PURPOSE:** If the position of the scissors gear is not correct, the paper feed registration will vary.

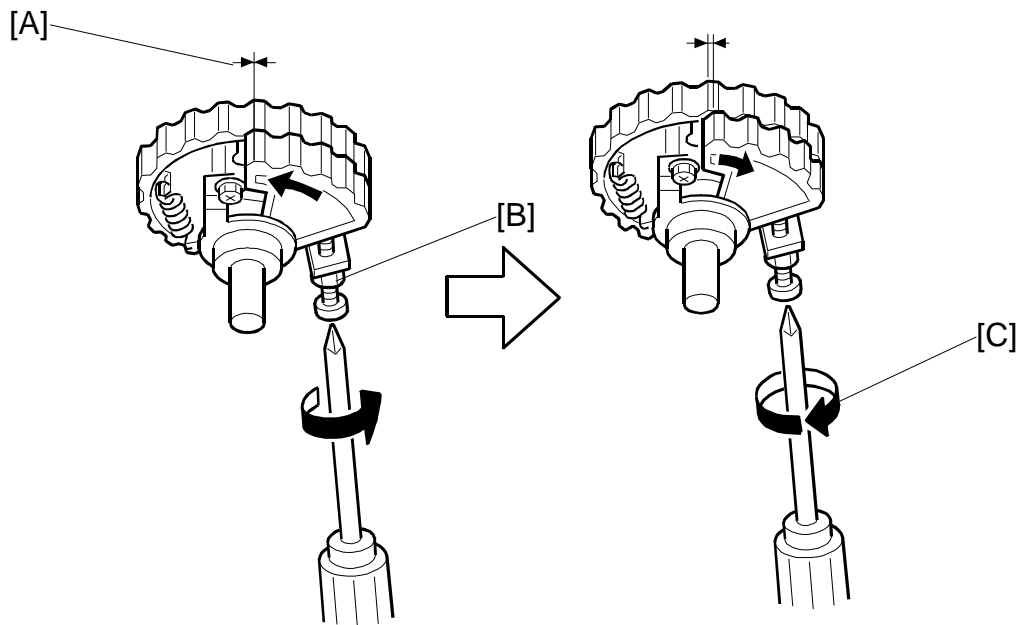

C235R605.WMF

1. Loosen the lock nut [B].
2. Tighten the screw, so that the gear meshes on both gears are aligned as shown [A].
3. Turn the screw fully counterclockwise circle to loosen it, as shown [C].
4. Holding the screw, tighten the lock nut [B].



### 6.11.5 IMAGE UP/DOWN SHIFT WORM-GEAR POTISION ADJUSTMENT

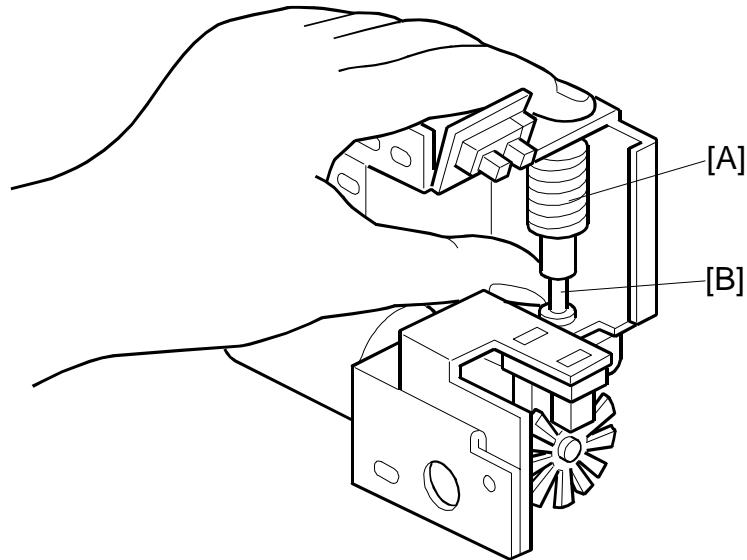

C235R127.WMF

Fully push up the worm gear [A], and push down the worm gear shaft [B]. While holding them together, secure with the 2 set screws.

Replacement  
Adjustment

### 6.11.6 IMAGE UP/DOWN SHIFT DRIVE UNIT POSITION ADJUSTMENT

**PURPOSE:** To take out any play while using the image up/down shifting function.

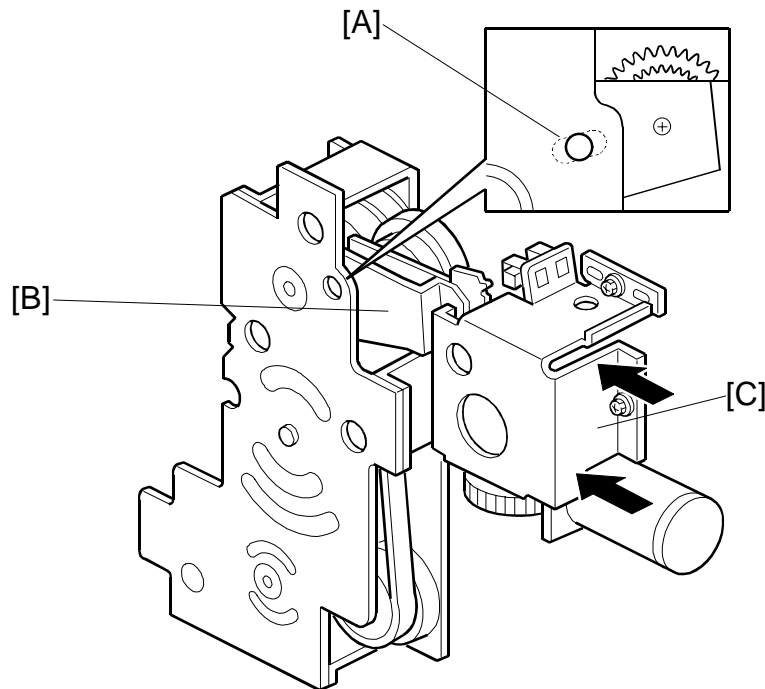

C235R124.WMF

1. Set the image shift arm [B] in the home position. Align the hole in the upper plate with the elongated hole in the image shift arm [A].
2. Push the image up/down shift drive unit [C] against the image shift arm sector gear, and secure the unit (3 screws, 3 connectors).

**NOTE:** 1) Set the arm without play in the vertical direction of the image shift arm.  
2) Do not push too strongly. Check if the image shift arm moves smoothly after securing the unit. If it does not, SC05-10 will light at power on.

## 6.12 PAPER DELIVERY SECTION

### 6.12.1 PAPER DELIVERY UNIT AND AIR KNIFE FAN UNIT

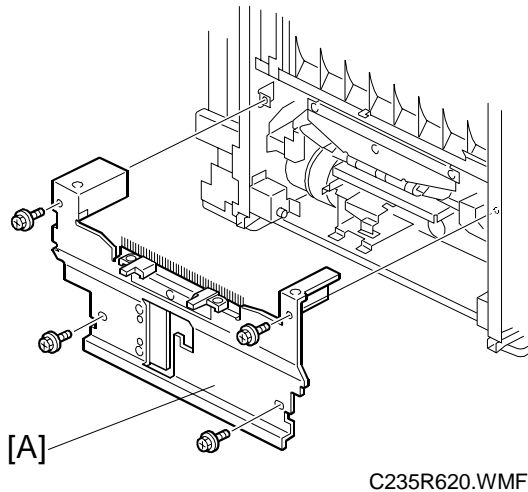

C235R620.WMF

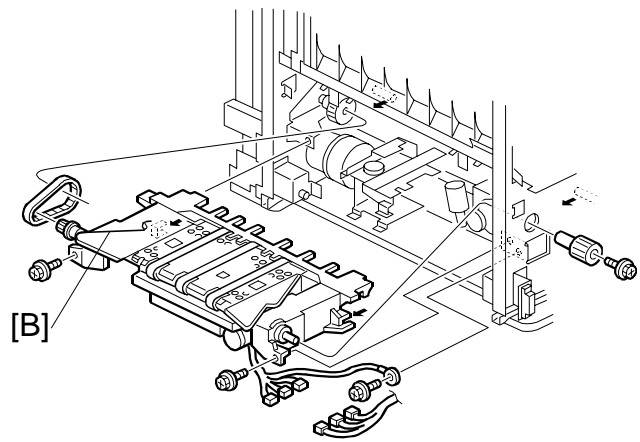

C235R615.WMF

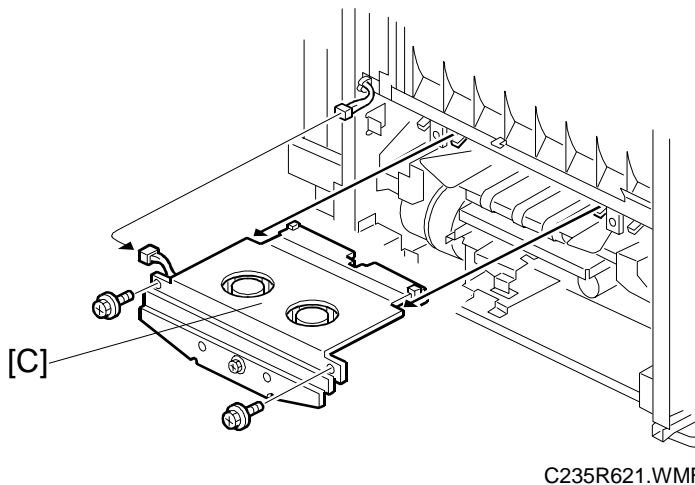

C235R621.WMF

1. Turn off the main switch.
2. Remove the paper delivery cover [A] (4 screws).
3. Remove the paper delivery unit [B] (2 screws, 3 connectors, ground wire, knob, belt).
4. Remove the air knife fan unit [C] (2 screws, 1 connector).

Replacement  
Adjustment

### 6.12.2 PAPER EXIT SENSOR AND TRANSPORT VACUUM FAN REMOVAL

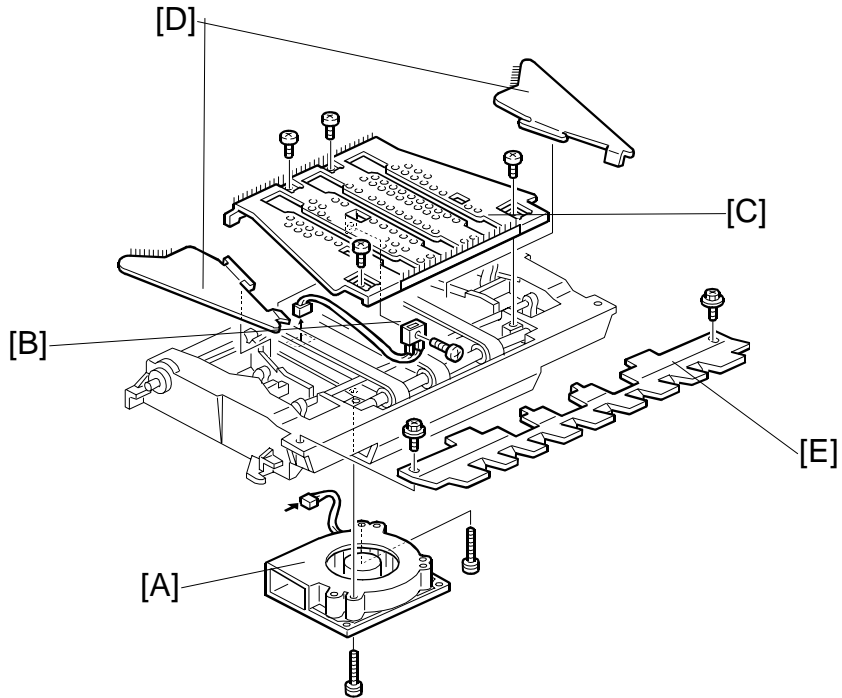

C235R026.WMF

First, remove the paper delivery unit. (See 6.12.1 Paper Delivery Unit and Air Knife Fan Unit.)

- A: Transport vacuum fan motor (2 screws, 1 connector)
- B: Paper exit sensor (1 screw, 1 connector)
- C: Upper cover (4 screws)
- D: Paper guide wings
- E: Paper pick-off plate (2 screws)

### 6.12.3 PAPER TRANSPORT BELT REMOVAL

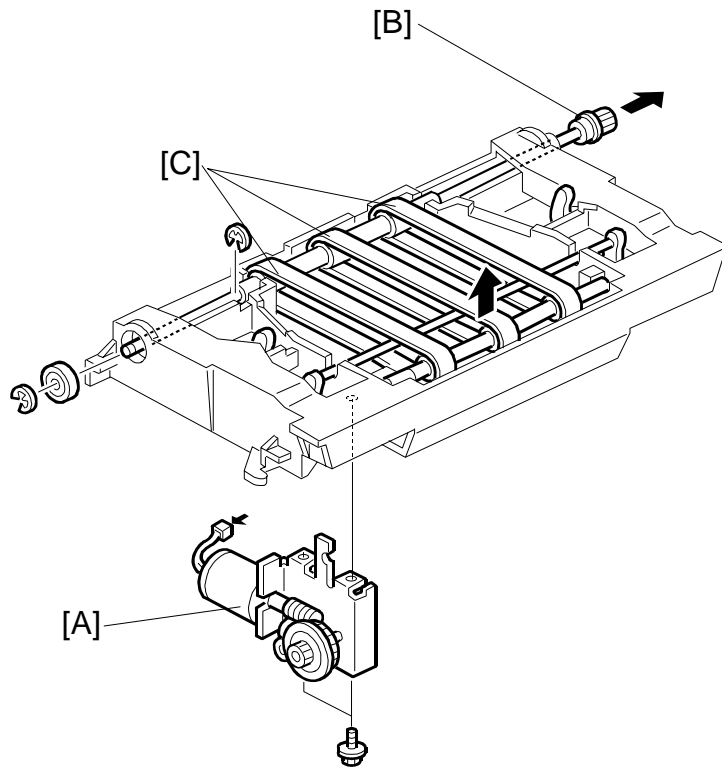

C235R027.WMF

First, remove the paper delivery unit (see 6.12.1 Paper Delivery Unit and Air Knife Fan Unit).

A: Wing guide motor unit (2 screws, 1 connector)

B: Drive roller shaft

C: Transport belts

Replacement  
Adjustment

### 6.12.4 PAPER EXIT PAWL REMOVAL

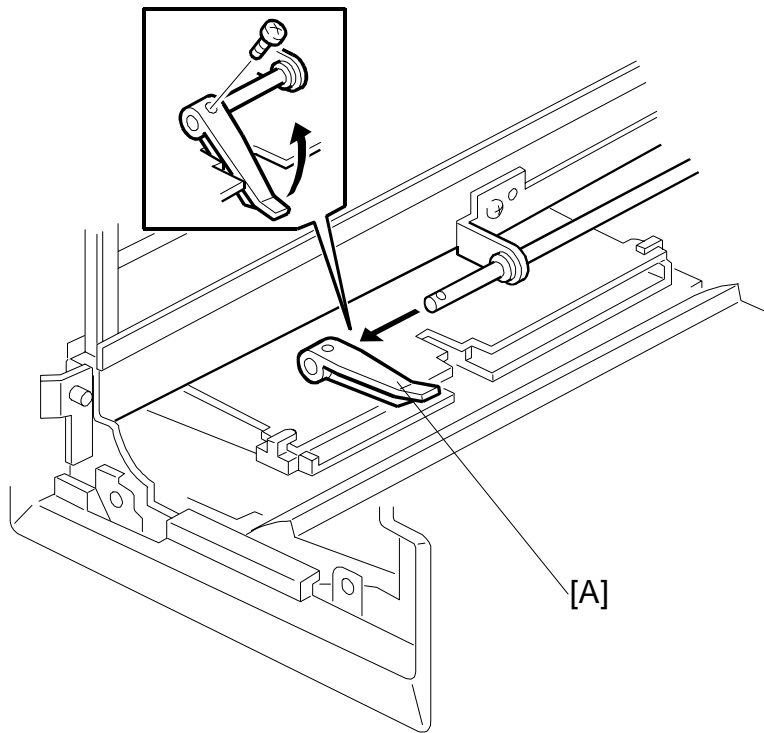

C235R619.WMF

1. Remove the drum unit.
2. Remove the paper delivery unit.
3. Remove the paper exit pawl [A] (1 screw).

## 6.12.5 GAP ADJUSTMENT BETWEEN PAPER PICK-OFF PLATE AND PRESSURE CYLINDER

**PURPOSE:** To ensure smooth paper feed to the paper delivery unit

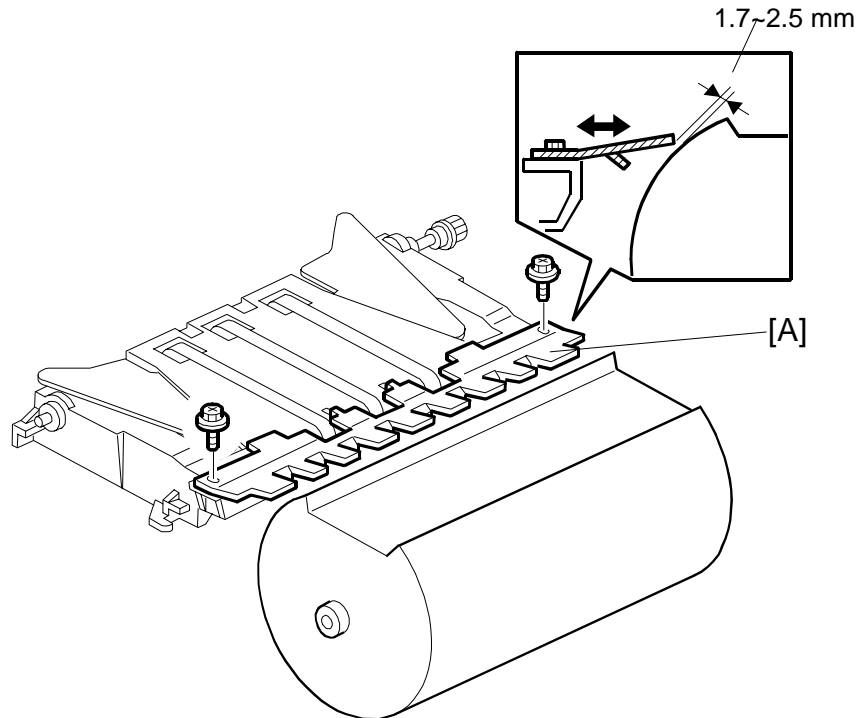

C235R025.WMF

1. Remove the drum.
2. Apply the printing pressure as follows. (Push the pressure cylinder up to the printing position.)
  - 1) Access SP 5-064-2, and select "ON" for the printing pressure release solenoid.
  - 2) Leave SP mode.
3. Adjust the clearance between the paper pick-off plate [A] and the surface of the pressure cylinder until it is 1.7~2.5 mm (loosen the 2 screws).

**CAUTION:** Be sure to perform this adjustment after pushing the pressure cylinder up to the printing position. If the gap is adjusted with the pressure cylinder in the non-printing position, the paper pick-off plate will damage the pressure cylinder when the printing pressure is applied and the pressure cylinder is pushed up, because the gap will be too small.

Replacement  
Adjustment

### 6.12.6 PAPER EXIT PAWL DRIVE TIMING ADJUSTMENT

**PURPOSE:** To ensure smooth paper feed, and to ensure that the exit pawl does not touch the master clamber on the drum.

**NOTE:** You must adjust this after the main drive belt is replaced.

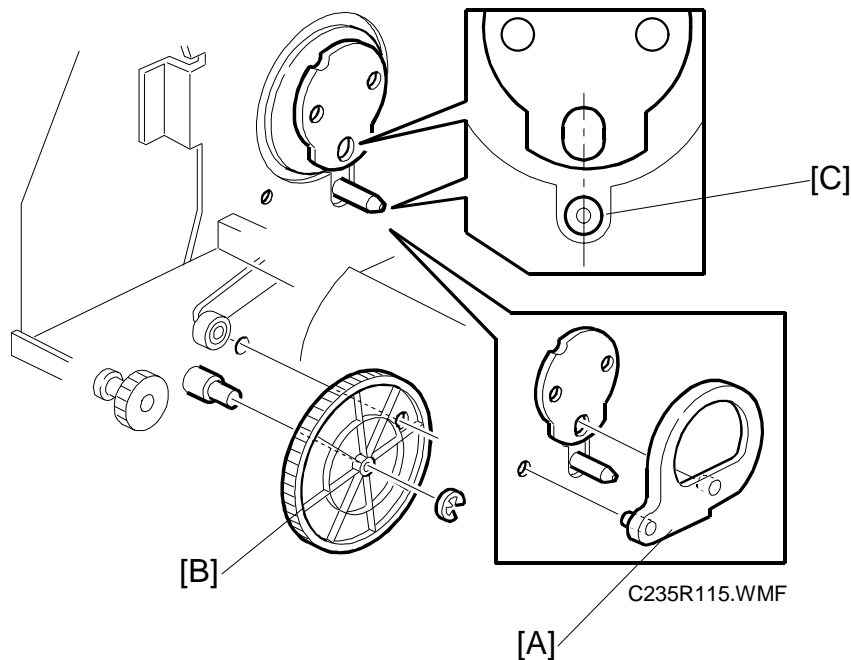

1. Remove the drum.
2. Remove the paper delivery unit. (See 6.12.1 Paper Delivery Unit and Air Knife Fan Unit.)
3. Make sure that the drum drive disk is in the home position.  
**NOTE:** Normally, the disk is in the home position after the drum is removed. If necessary, set the drum securing tool [A] to make sure that the drum drive disk is in the home position. (If the special tool is not available, align the long positioning hole in the drum drive disk exactly with the shaft [C] below it as shown.)
4. Make sure that the positioning holes in the rear frame and the drive gear [B] are in line as shown [C].
5. If the holes are in line, the paper exit pawl drive timing is OK. If they are not, remove the gear [B] and reinstall it so that the holes are in line.



### 6.12.7 GAP ADJUSTMENT BETWEEN EXIT PAWL AND DRUM

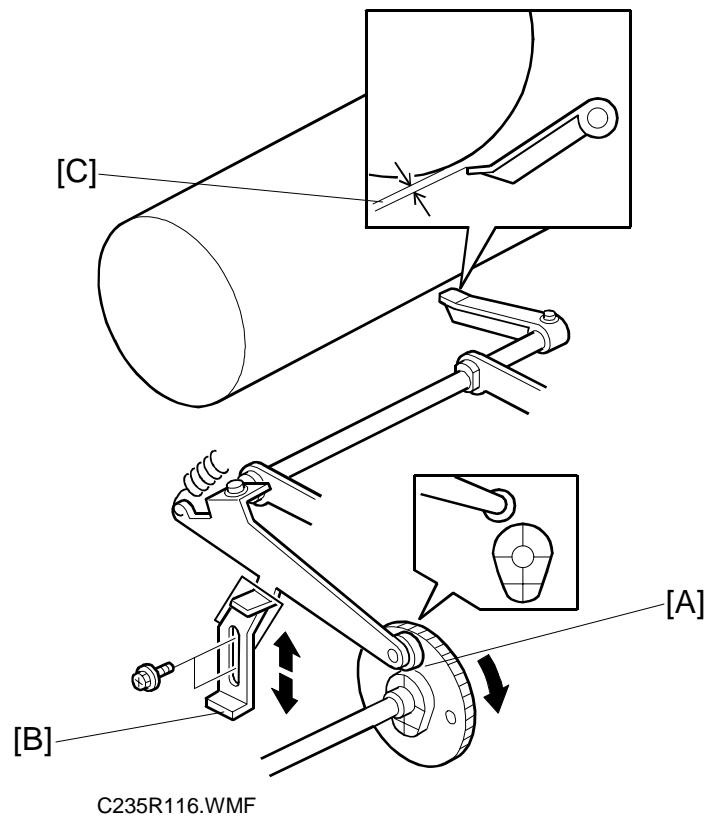

**PURPOSE:** To ensure that the paper is delivered without paper wrap or damage.

1. Turn the main drive manually, so that the bearing [A] of the exit pawl arm [C] rides on the low point of the cam.

**NOTE:** Use the main drive rotation knob to turn the main drive.

2. By moving the adjusting plate [B], adjust the clearance [C] between the drum and the top of the exit pawl until it becomes  $1 \pm 0.5$  mm.







---

## 7. POINT TO POINT DIAGRAM

- Location Map
- Section A
- Section B
- Section C
- Section D
- Section E
- Section F
- Section G
- Section H

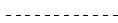
**NOTE:** The symbols used in the diagrams are as follows:

**- SYMBOL TABLE -**

	AC Line
	DC Line
	Pulse Signal Line
	Signal Direction
	Active High Signal
	Active Low Signal

PP2.WMF

# Location Map

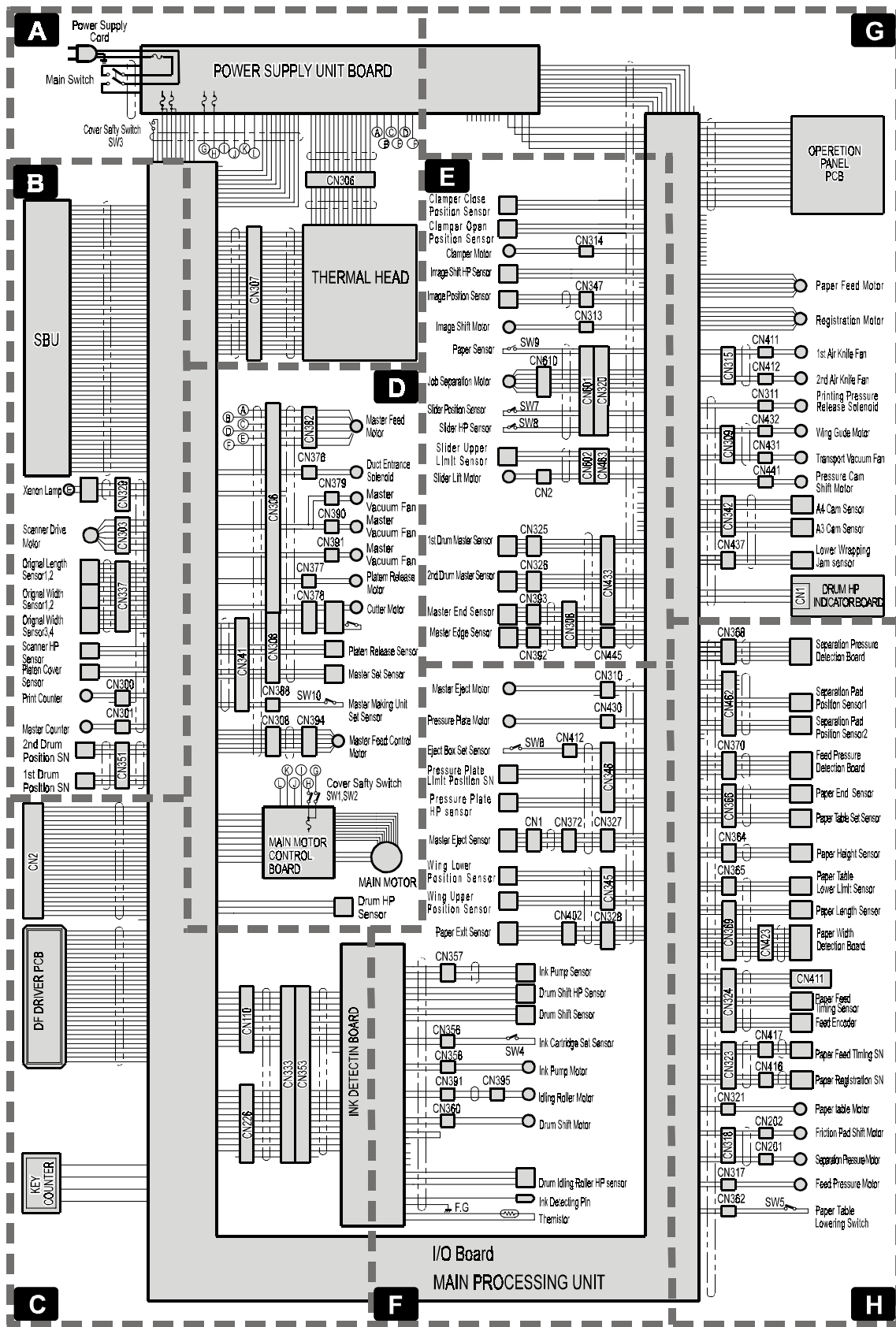

# Section A

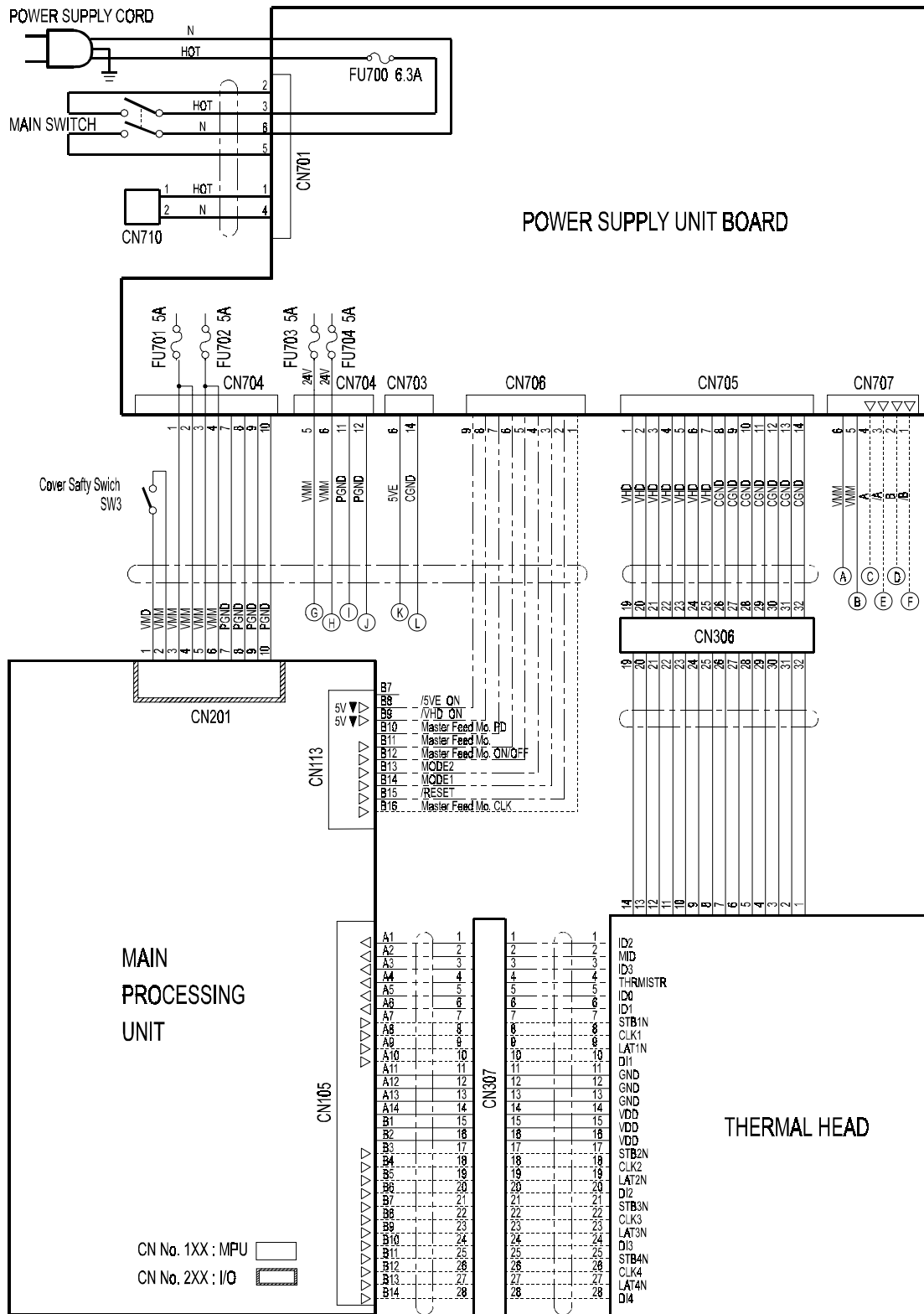

P-to-P

# Section B

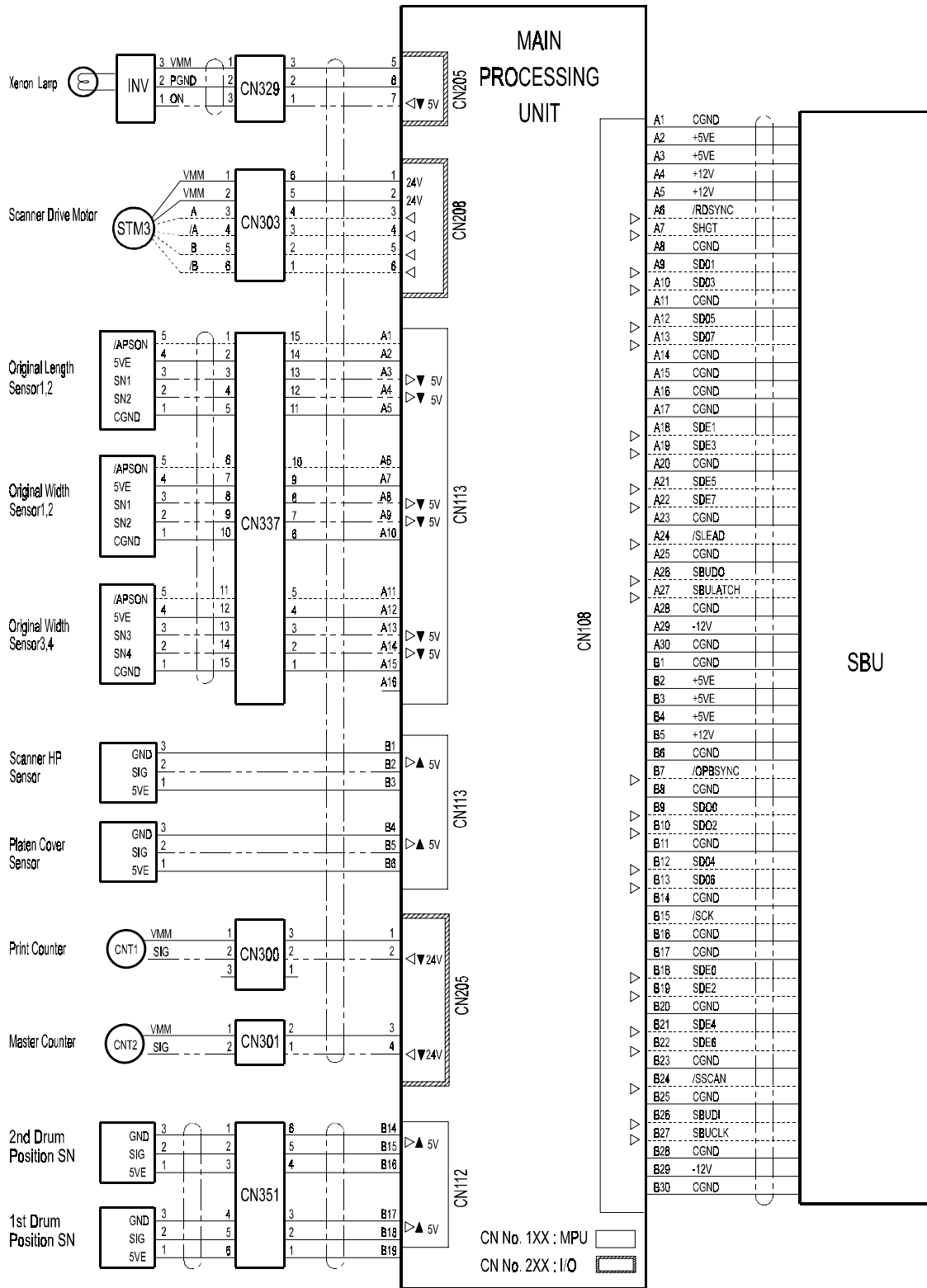

# Section C

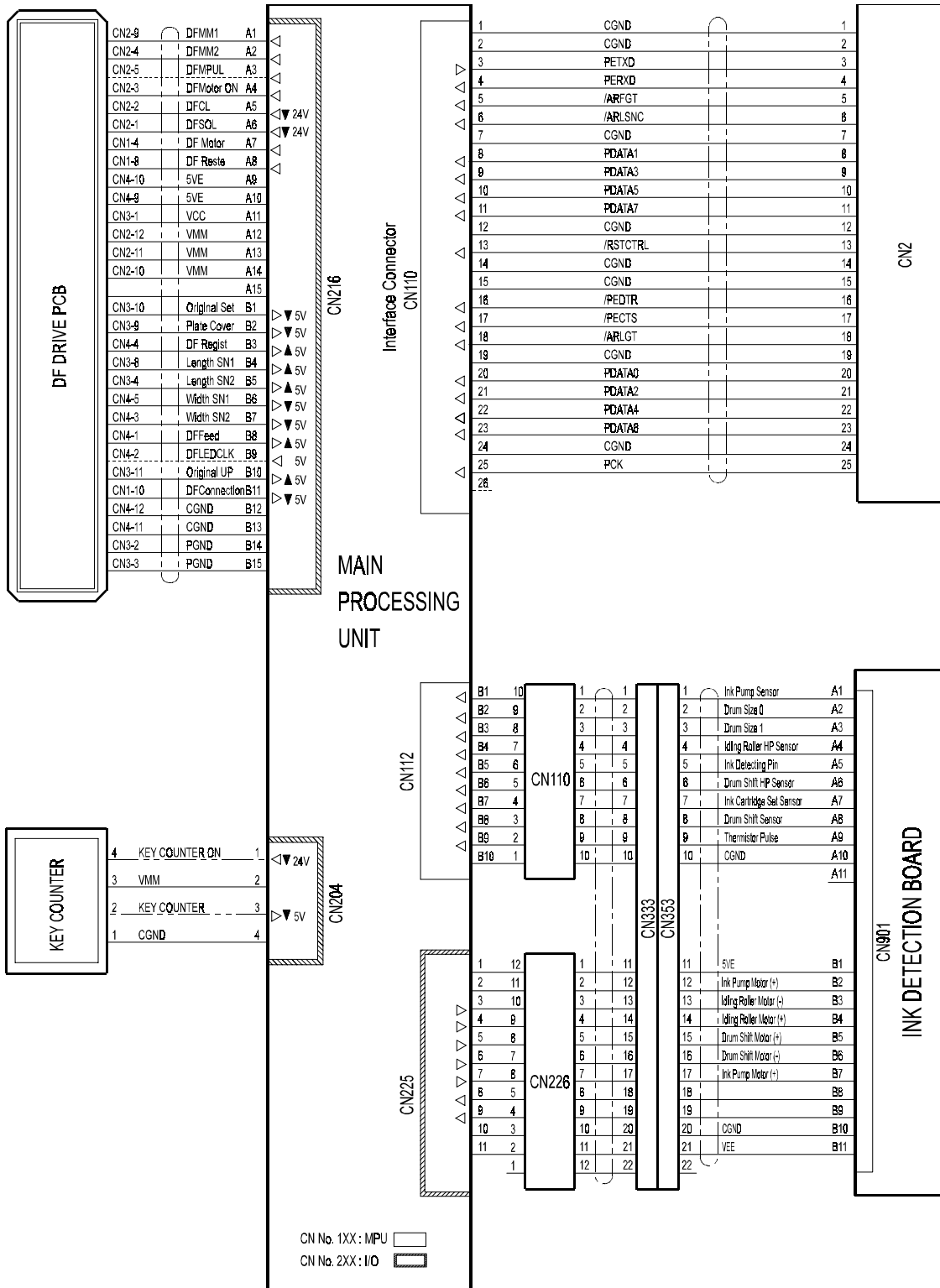

Section D

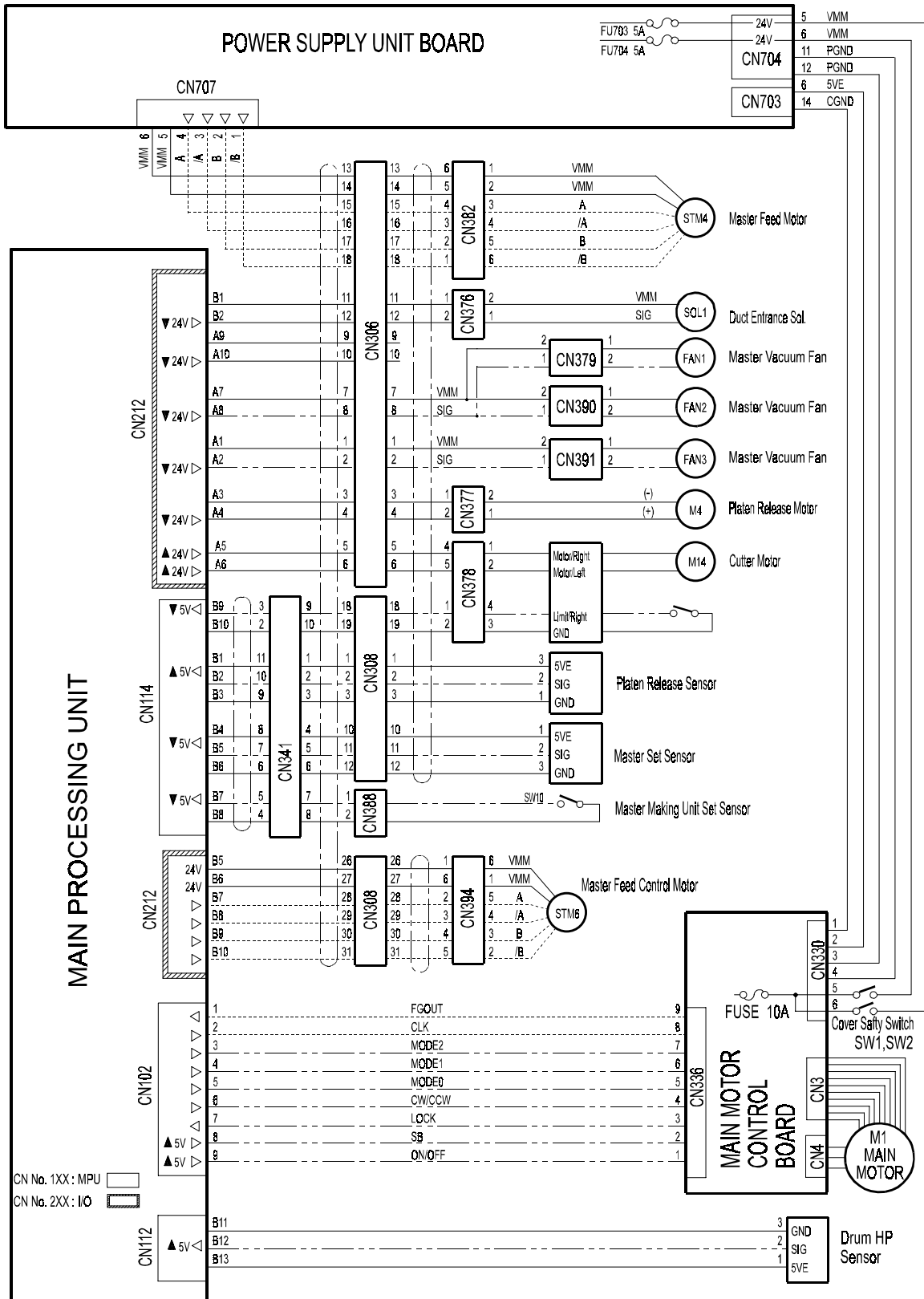

C235S504.WMF

# Section E

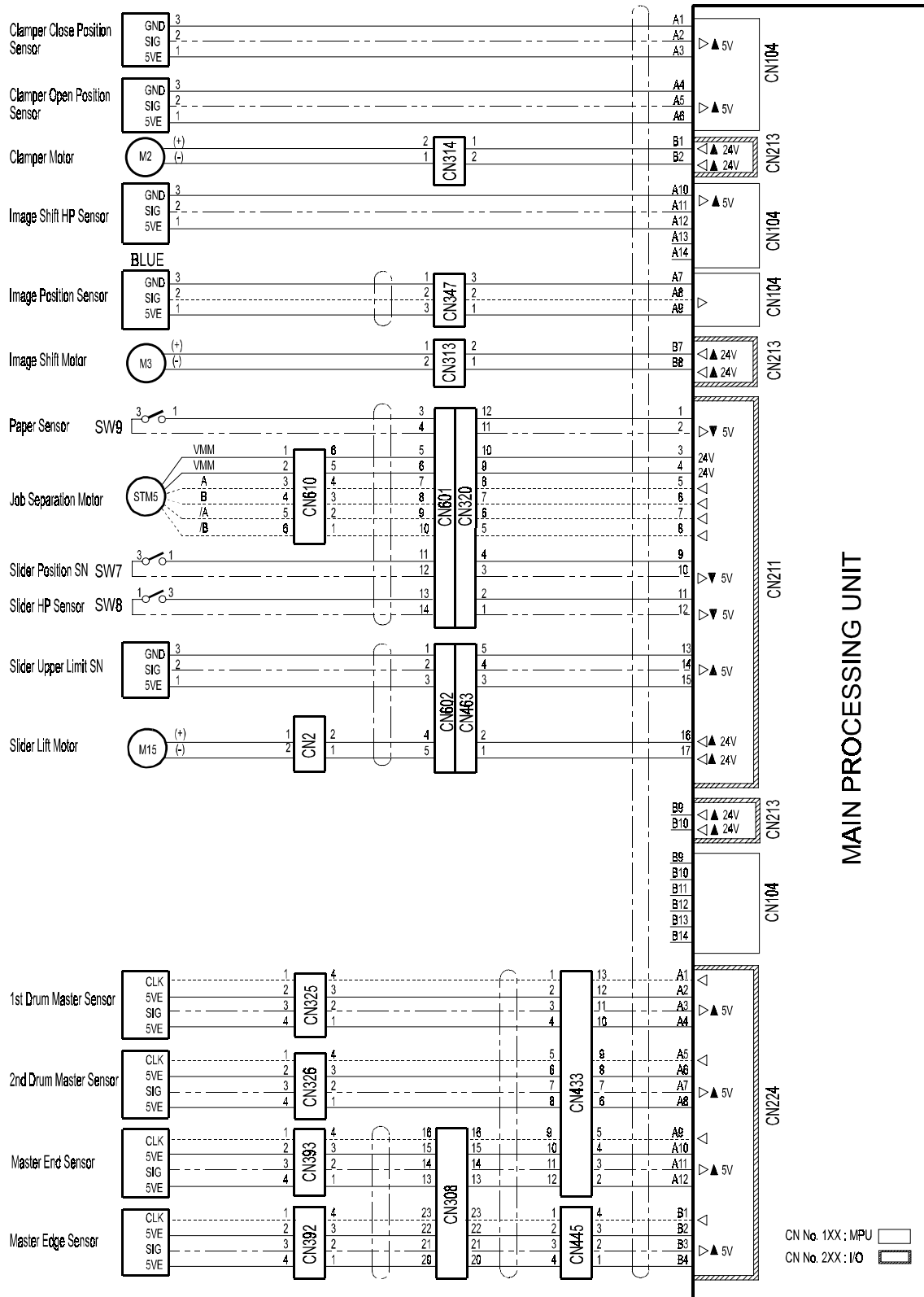

C235S505.WMF

P-to-P



# Section F

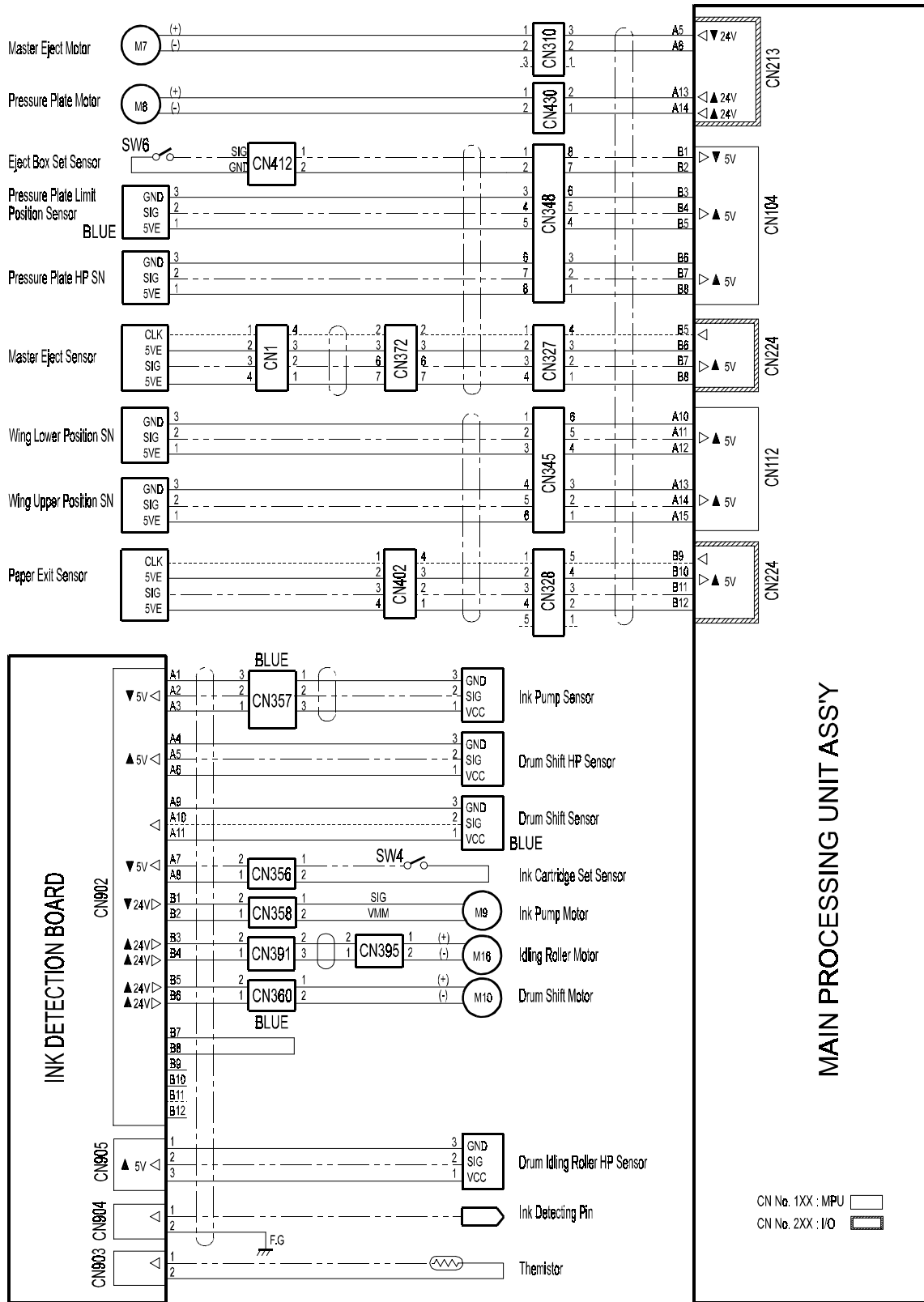

## Section G

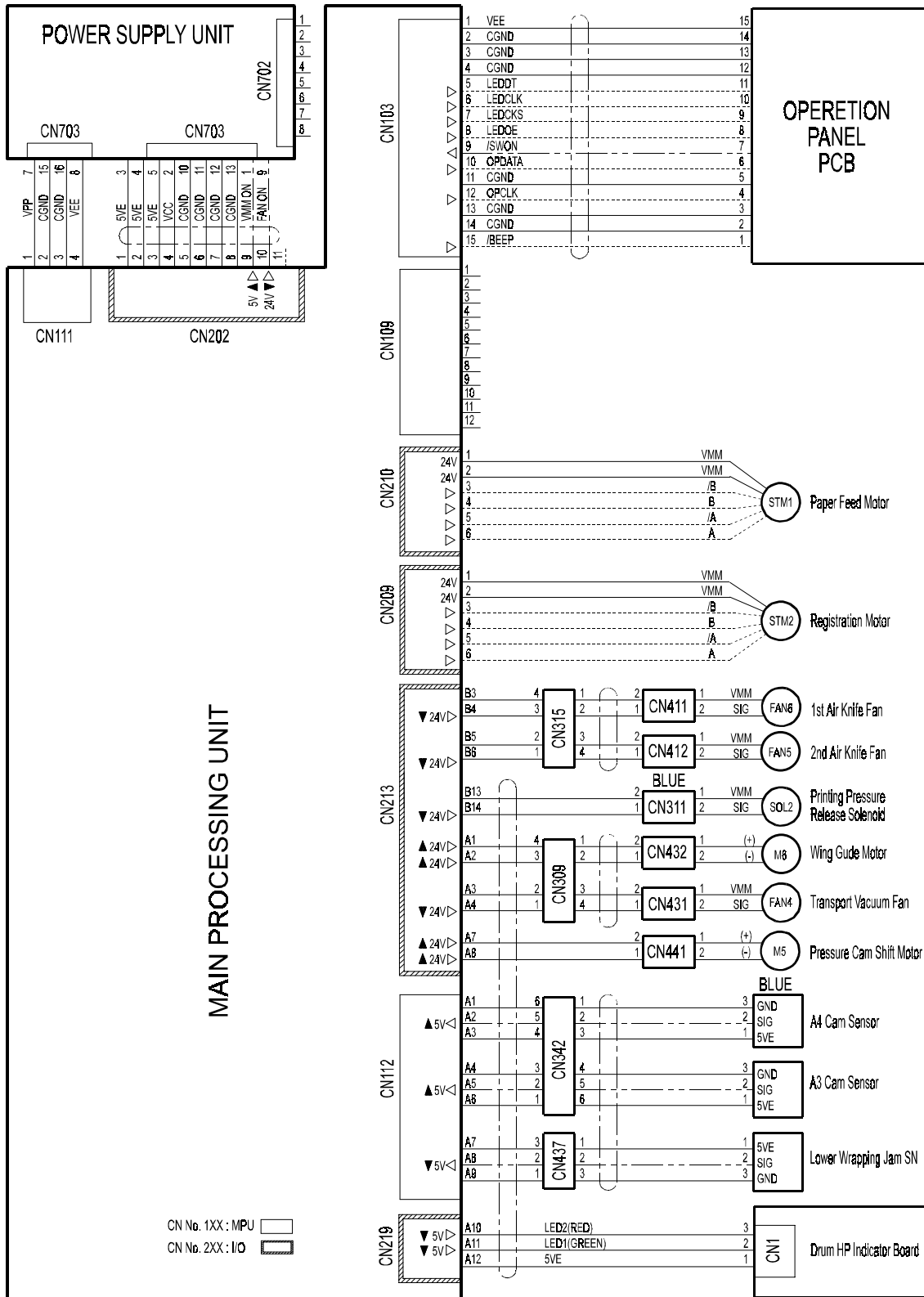

C235S507.WMF

P-to-P

# Section H

